

AMIGA FORMAT

ISSUE 43 ■ FEBRUARY 1993 ■ £3.95

Stupendous!
Complete £50 package



The **AMIGA** Collection
FORMAT

Prodata

No.1 RRP £60
From ARNOR

Do you realise just how useful a database can be? If not, you soon will, when you start using this powerful complete package!

● All Amigas ● 1Mb Required ● All Amigas ●

EXPLODED!

Find out how the Amiga really works as we blow apart its innermost secrets!

FIGHTING FOR THE TOP SPOT

AMIGA Arcade
Issue 43
FORMAT

THE SIMPSONS... BART'S WORLD

Bart's back! And this time he's having more fun than ever in this amazing playable demo from Accolade!

NODDY'S PLAYTIME

Ever-popular cartoon star introduces a great way to learn in this enchanting demo from Jumping Bean

● 1Mb needed ● All Amigas ● 1Mb needed ●

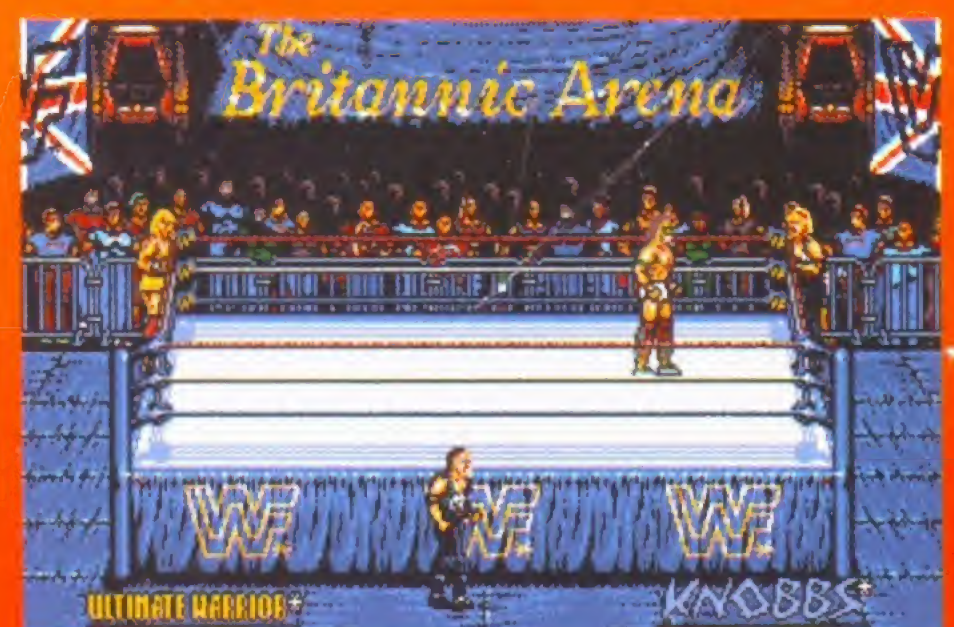

One of these games is great - one isn't. Find out which is which inside!

THE AMIGA IN 1993: Read our amazing predictions!
GAME GREATS: LucasArts' latest and sporting greats!

Future
PUBLISHING
Your guarantee of value



IF YOU CAN'T STAND



Whilst publishing his underground comic Jack Debs has unwittingly created a parallel universe inhabited by cartoon characters known as DOODLES. You are transported into COOL WORLD and seduced, through engaging messages, by the Doodle vamp... HOLLI. Visual jokes and gags punctuate your adventure as you hop to and fro between reality and COOL WORLD. But Holli's dream is to shed her Doodle identity... to become a real woman - with a real interest in Jack! Her dream could destroy both worlds. Kiss goodbye to Jack... and hello to oblivion!



Once again, the Rampage™ Team and many more... Watch them in Match at Mad and skill. Won the European

TM & © 1992 PARAMOUNT PICTURES
ALL RIGHTS RESERVED.

AMIGA - ATARI ST -
IBM PC & COMPATIBLES



OCEAN SOFTWARE LIMITED, 2 CASTLE STREET
TEL: 061 832 6631

THE LETHAL WEAPON



WWF Superstars unite for the grand European Tag Team Championship in your favourites, Hulk Hogan**, Ultimate Warrior* they travel across Europe to square off in the ring like the Natural Disasters* and the Nasty Boys*. Follow them to the Grand Finale at Wembley Stadium in London. Test your strength and your team-mate to achieve the ultimate goal - the WWF Tag Team Title.



A multi-level shoot 'em up based on aspects of all three LETHAL WEAPON movies. You can choose to be either one of the two high fire-power cops... each having his individual strengths - and weaknesses! There are many missions to complete including the rescue of a kidnapped girl, the pursuit and arrest of drugs runners, finding and arresting a police murderer, plus many more. You choose the level to suit your objectives within the game-play. It's mean, fast and... LETHAL!

LETHAL WEAPON, LETHAL WEAPON 2, and LETHAL WEAPON 3 names, characters and all related indicia are trademarks of Warner Bros. Inc. TM & © 1992 Warner Bros. Inc. All Rights Reserved.



AMIGA FORMAT 43 FEBRUARY 1993

EDITORIAL DEPARTMENT

EDITOR Damien Noonan
REVIEWS EDITOR Neil Jackson
FEATURES EDITOR Tim Smith
TECHNICAL EDITOR Pat McDonald
PRODUCTION EDITOR Gary Lord
STAFF WRITER Andrew Nuttall

ART DEPARTMENT

ART DIRECTION Marcus Dyson
DESIGN Sue White

ADVERTISING DEPARTMENT

GROUP AD MANAGER Jonathan Bint
AD MANAGER Duncan Ferguson
SENIOR SALES EXEC Robert Anderson
SALES EXEC Anne Green

PUBLISHING

ADVERTISING PRODUCTION Tracey O'Donnell
PROMOTIONS ASSISTANT Tamara Ward
CIRCULATION DIRECTOR Sue Hartley
CIRCULATION ASSISTANT Kate Elston
PUBLISHER Greg Ingham

ADVERTISING COMPLAINTS

Contact Alison Winter, Advertising Complaints,
 30 Monmouth Street, Bath BA1 2BW.

PRINTED IN THE UK BY

Chase Web Ltd, St Ives PLC, Plymouth
 NEWSTRADE DISTRIBUTION, UK
 Future Publishing, 0225 442244
 NEWSTRADE DISTRIBUTION, OVERSEAS
 MMC Ltd 0483 211222

AMIGA FORMAT

30 Monmouth Street
 Bath, AVON, BA1 2BW
 Telephone 0225 442244
 Facsimile 0225 446019

SUBSCRIPTIONS, BACK ISSUES and MAIL ORDER

Future Publishing, Somerton,
 SOMERSET, TA11 6TB
 Telephone 0458 74011
 Facsimile 0458 74378



No part of this publication may be transmitted or reproduced in any form without the permission of the publishers.

Post-festive, but still mildly amusing joke of the month:

Did you hear about the dyslexic devil-worshipper?
 He sold his soul to Santa.

Member of the Audit Bureau of Circulations.



Registered Circulation
161,256
 Jan - July 1992

News

Amiga Format is going live! 19
 Details of the big event of 1993 - our very own show!

Join the Red Nose Day fun! 19
 How the nation's gamers are getting involved

Screenplay 57

AV8B Harrier.....	65
Alien Breed - Special Edition.....	111
Bignose the Caveman.....	108
Bill's Tomato Game.....	76
The Dream Team Compilation.....	109
Doctor Who - Dalek Attack.....	69
Fantastic Worlds Compilation.....	110
HistoryLine 1914-18.....	104
Indiana Jones - The Fate of Atlantis.....	72
Joe and Mac.....	89
Krusty's House of Fun.....	88
Lethal Weapon.....	68

Streetfighter 2 vs WWF2 82 and 64
 Who wins the ultimate battle of the beat-em-ups?

Your turn! Part 5 113
 In which Bullfrog reveal the last secrets of game-making

Gamebusters 117
 Full solution for Beast 3 and many more hot game tips

Nick Faldo's Golf.....	90
Piracy.....	65
Premier Manager.....	58
Raving Mad Compilation.....	111
Strategy Masters Compilation.....	110
Streetfighter 2.....	82
Super All-Stars Compilation.....	108
Super Fighter Compilation.....	109
TV Sports Baseball.....	108
TV Sports Boxing.....	108
WWF2 - European Tour Rampage.....	64
Waxworks.....	89



THE BIG FIGHT
 Streetfighter 2 versus WWF2, the two most-hyped games this year. One's great, the other's grim: but which is which? Find out now!

Reviews

VideoMaster 136
 The world's first video digitiser and sound sampler in one!

Boom Box 140
 Keen on music but don't know where to start? Try this!

GigaMem 144
 A totally unique concept that treats your hard drive as RAM

Understanding Imagine 2 146
 This book makes the world's best ray-tracer easier to use...

Real Things - Dogs 146
 New animated clip art for Deluxe Paint - now in HAM!

Oki OL-400 printer 148
 Ever seen an LED printer before? It's laser quality...

The Publisher 150
 Setting a new standard in excellent DTP for a bargain price



REVIEWED
The Publisher
 Budget DTP scales new heights with this new package that has features previously unseen at the price. See if it makes the grade on Page 150.



REVIEWED
Video Master
 Microdeal's budget multimedia package allows sound and video digitising all in one package. We put it to the test on Page 136.

Regulars

PD 165
 Get great software for hardly any hard cash outlay...

Workbench 185
 The answer to all your questions? Well, some of them...

Answerfile 190
 Yet more answers, but this time in brief yet in depth...

Letters 203
 Isn't it amazing what other Amiga owners have to say?

Special offers 176
 If you want an AMOS manual, this is the place to get it!

Subscriptions 181
 Seriously! This is a great magazine, so commit yourself!



IN PD UPDATE:
 Return of a classic: Pacman hits back in a new version that will cost you only a touch more than the price of a blank disk!



IN PD DEMOS:
 Possibly the best music demo you've ever seen (and heard). Or possibly not. Still, Jesus on E's is an art form in itself...

Exploded! The secrets of the Amiga

Or 'How it Works: the Amiga'. Never before has anyone given you this much information on how the best computer in the world functions, revealing all of its innermost secrets. We'll show you absolutely everything, from how a chip works, all the way up to how a monitor displays a picture. It's the ideal guide to computers for the complete beginner and even experienced Amiga owners can learn a thing or two!

PAGE 32



What will happen in 1993...

Four new Amigas to be released! One is a console, one is a full-colour portable! CD drives in all the low-end machines! Can this possibly be true? What are the other two machines? And what do we really think will – and should – happen over the course of this year...?

PAGE 48

Welcome to Amiga Format!

And welcome, indeed, to 1993! A Happy New Year to you all (though we're a week or two late with it – who really minds, eh?) and an extra-special welcome to all new readers, because there's quite a few of you at this time of year.

All you lucky people who got a new Amiga for Christmas, you're the ones I'm talking about. You have ahead of you, stretching to the horizon, a whole new world of entertainment and enterprise to explore. Or something like that.

Anyway, the point is that this issue is kind of dedicated to you lot. That's why we decided it was a good time to explore how the Amiga works, and do it in a way that we don't remember ever seeing in a computer magazine before – ever.

It's always mystified me exactly how computers work. What's going on inside a silicon chip? How can you get binary numbers, like 1s and 0s, and make them into maths problems? It's a mystery.

But not any more. By the time you've finished reading this month's article, with any luck you'll be one of the most clued-up people on the planet when it comes to sussing out – and explaining to other, less fortunate souls – how a computer works.



Damien Noonan, Editor

So we hope you enjoy that. Elsewhere in the magazine, we've got something that may appeal a little more to the old hands. It's only two pages long, but packed in there you'll find all the major issues facing the Amiga at the moment.

Not only do we predict four possible futures for the Amiga, in the shape of four machines that Commodore may (or may not) consider releasing, but we also set the agenda for the major Amiga issues of the year. Will people listen? We'll see!

COVERDISK

Turn to Page 6

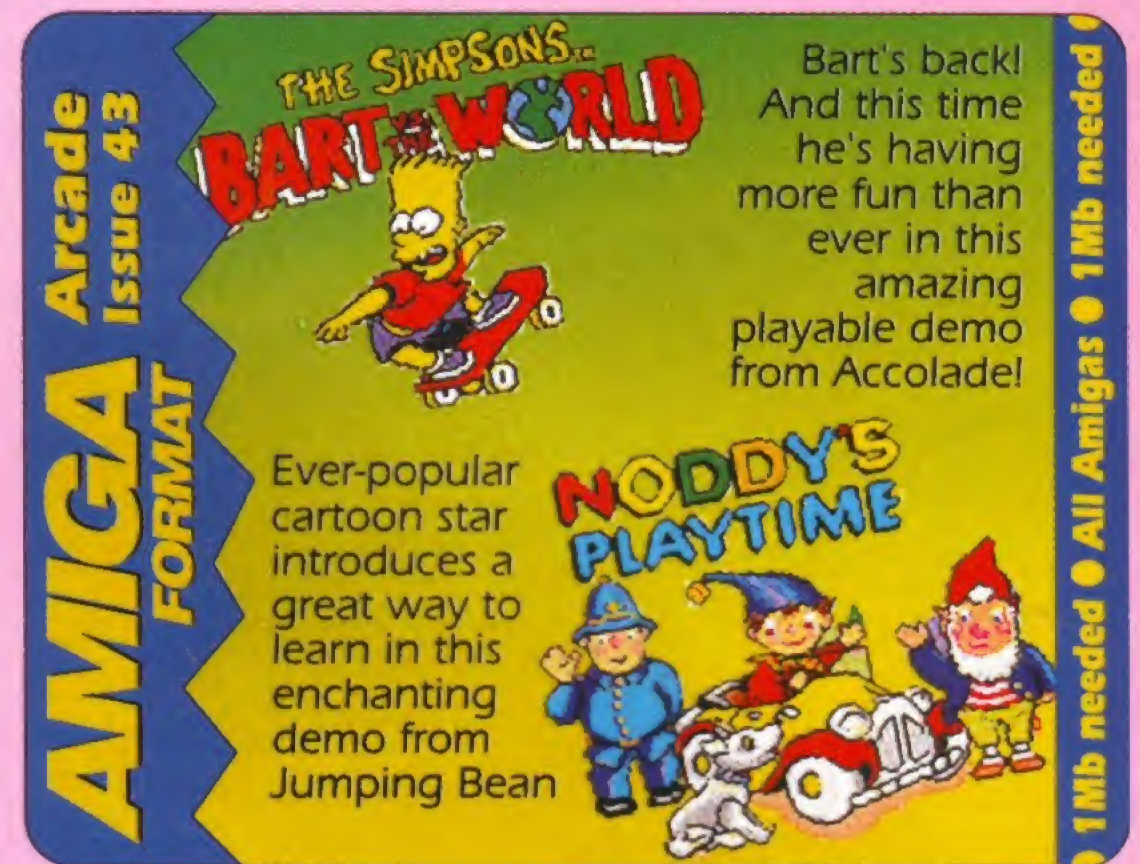

Bart Simpson versus the World

Fully playable 'taster' featuring sample bits from the Chinese levels of Bart vs the World, Accolade's latest fun-packed whizzaround featuring the world's best-known bad kid!

Noddy's Playtime

Playable/useable demo featuring two of the 10 activities from Jumping Bean's delightful educational package, including a test version of the lovely kids' paint package...

Bullfrog Convert

You're using Devpac2 for your programming, but you want to create some graphics. Simply use DPaint and then this and you're laughing!

Alien Breed Fix

Courtesy of Team 17, here's a vital little modification you can make to your copy of the Special Edition to give it that little extra!



AF Collection No.11 Prodata Page 13

Database? What use is a database? Well, as soon as we show you how to use it you'll release it's one of the most useful programs you can have. Start collating information now!

Coverdisk

Grab that important piece of magnetic media that's securely taped to the front of the magazine. Now, let **Pat McDonald** show you how easy it is to get the most out of your Coverdisk, and tell you all about those two contrasting young juveniles... Noddy and Bart!

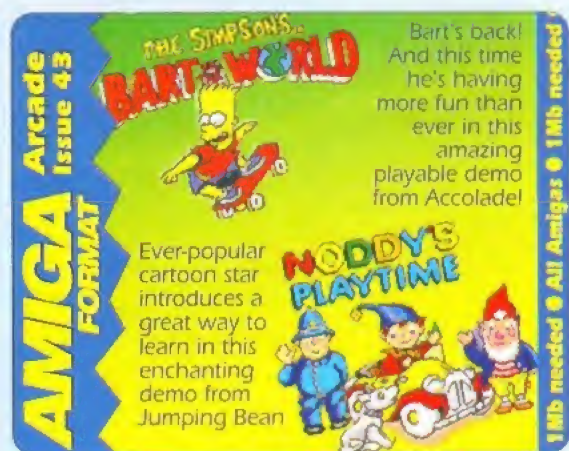

GETTING STARTED

From the Coverdisk, you will be able to install two demos (*Noddy and Bart Vs The World*), fix defective *Alien Breed Special Edition* disk and use the picture-to-machine-code *Convert* program. The instructions for *Convert* can be found on Page 114. If you want information on the *Prodata* disk, turn to Page 13.

You can look at the *Convert* document or run the *Alien_Breed_Fix* straightaway, again by double clicking. However, to actually play the *Noddy* or *Bart* demos, you first have to make demo disks. You will need two blank disks, one for each demo, preferably freshly formatted, on which to install them. Coverdisks are incredibly simple to use, and if you're a first-time user then don't worry, just follow these brief, but informative, instructions on how to get the most from your *Amiga Format* Coverdisk.

1) FORMAT A DISK OR TWO

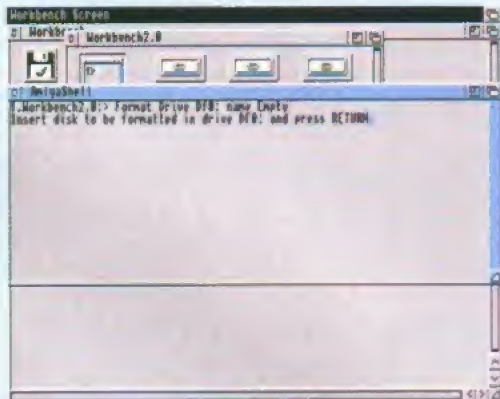

This is Workbench 2 formatting a disk, but every version of Workbench should be fine for this method.

There are a dozen ways to format disks – this one works on all Amigas. To format a disk so that it's ready to install a demo on, load your Workbench disk that came with your Amiga. Then double click through the disk until you find a Shell or CLI icon – if they're not obvious you can usually find one in the System directory. A window will appear – just type this and press Return:

```
Format Drive DFO: name Empty
```

The DFO bit is DFZero, not DFO as in Oh. Don't mix your letters and number, it upsets computers. The computer will then ask you to insert a blank disk to format (blank 3.5-inch disks are widely available from computer shops) and then press Return. The disk is formatted. If you want two blank disks, type the Format line again – but first write-protect the Workbench disk if it isn't already.



Double click on either of the Install icons - they should work fine one after the other.

2) START THE COVERDISK

Remove all disks and either turn your Amiga off, or reset the machine (just press Ctrl and the two 'A' keys either side of the space-bar). Then insert the Coverdisk into a disk drive. After a short while, and a few warnings to write protect your Coverdisk (always a good idea) you will be left on a screen called the Workbench. Move the mouse pointer (over to the Coverdisk icon and click twice rapidly with the left mouse button. Then double click again on either the *Install_Bart_to_Empty* icon or the *Install_Noddy_to_Empty* icon.

3) ONE DISK SWAP

If you have Workbench 3, then wait for the Disk Masher message to put in a blank disk and press Return, and simply do it – the strange messages are irrelevant to you. Everybody else (the majority) should wait for the box asking for the Coverdisk back, take out the Coverdisk, put in a blank and click on the Cancel box.

This is why you were warned to write protect the Coverdisk – if you don't, and also ignore the warning messages, you have just wiped your Coverdisk. Never

mind, you did make a backup – didn't you? The Install program does not require you to swap between the Coverdisk and the blank disk, and takes about three minutes to make one demo. The words 'All Done' will appear and you will be returned to Workbench.

If you are very, very unlucky then you might get a DMS error code. If you do then please return the disk together with return postage and a note saying 'this disk was not duplicated properly - please replace it' to Disc Copy Labs at the address on Page 10. Don't worry though, only a minute percentage of our Coverdisks have errors.

4) ER, THAT'S IT

And there you have it, a simple procedure for getting demos off the Coverdisk. Once you have made the demo disks, they will 'autoboot', that is start working immediately when inserted into a reset Amiga.

Future Coverdisks will probably use this or a better method in order to get more on to the disk. It's a necessary procedure – *Bart* or *Noddy* fit on to one normal automatic disk, not both. Previous attempts at this sort of thing have met with varying degrees of success, but you should find that the Coverdisk becomes much easier to use from this point on. Oh, and by the way, I hope you had a good Christmas.

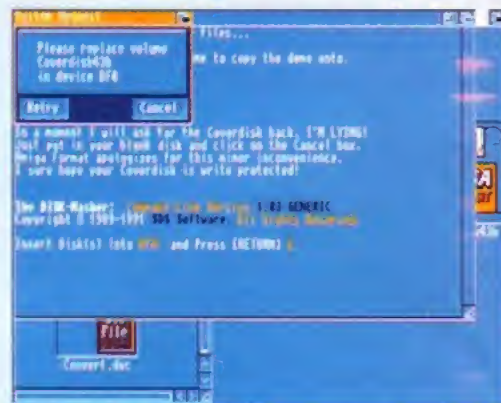

Everybody, put in a blank disk. A1200/A4000 users press Return, everybody else click on Cancel.

ALIEN BREED FIX

TEAM 17 PAL/NTSC

Just got hold of the rather excellent game *Alien Breed Special Edition*? Does it crash when you get on to the later stages of the game?

If so, you've got one of the early production disks which contain a bug – that's why the game crashes. Luckily, the *Alien_Breed_Fix* on the Coverdisk will correct the bug on the second (data) disk allowing you to complete the game without any hitches.

It really is very easy to use. All you have to do is switch on your Amiga and insert the Coverdisk. Then, when a Workbench screen appears, double click on its icon, and again on the *Alien_Breed_Fix* icon.

The fix then runs, and asks you to put in the data (second) disk from the game. Click the left mouse button to fix it, and the right mouse button to exit the program and get back to the Workbench screen.

Noddy's Playtime

JUMPING BEAN COMPANY
PAL/NTSC

WELCOME TO A preview version of *Noddy's Playtime* – a creativity and entertainment package based on solid, educational principles for three-to-seven year olds! This is a fully functional demo of two of the 10 programs which make up this amazing package. The two demos are *Noah's Ark*, a jigsaw game, and *Noddy's Paint Pot*, a simple drawing program.

A time-out of five minutes has been introduced into these programs for this preview version. The full version of *Noddy's Playtime* also includes; *Railway Station*, a memory game; *N & B Works*, observational game; *Chimney house*, musical fun; *Farmyard*, animal matching; *Market Place*, letter and word recognition; *Post Office*, counting and arithmetic skills; *Police Station*, a maze game; and a driving menu which links all of the games together and allows children to take control of Noddy's car and explore Toytown.

USING NODDY'S PLAYTIME



The demo contains only two activities to choose from – the real program contains about 10.

First, you have to make a demo disk from the Coverdisk. You can then load the preview version of *Noddy's Playtime* by inserting the demo disk into the internal drive and resetting. You will soon see an Introductory Screen. In the preview this contains two icons – by clicking the one with an ark you will load *Noah's Ark*, by clicking on the icon showing Noddy holding a paintbrush you will load *Noddy's Paintpot*.

You can control this preview using the mouse, a joystick or from the keyboard using the cursor keys. Once you have played a sequence of five games in *Noah's Ark* or after five minutes in *Paint Pot* the program will return to the Introductory Screen. Should you wish to return to this screen before this time you should press Esc or click on Noddy's car (found in the bottom right-hand corner of the screen).

NOAH'S ARK

This demonstration presents you with the second level of this activity. The release version operates on three different levels and contains many more puzzles. This version contains five puzzles. In the window on the left of the screen are the jumbled pieces of a jigsaw puzzle.



Noah's Ark is very simple - just arrange the pieces properly. Click on Big Ears if you get stuck.

When placed together in the correct order these will make a picture of an animal. To do this you should pick them up, one at a time, and place them into the window on the right.

Move the hand over a piece (using the mouse, the cursor or keypad keys) and click on the left mouse button or press Return. Now move the piece into its correct position in the window on the right and put it in place by clicking on the left mouse button, or pressing Return. If you place a piece in an incorrect position you can pick it up again and put it in a new position in either window.

If you want to check that you have placed any of the pieces of the puzzle in their correct places then you can do so at any time just by clicking on the Big Ears icon. If all of the pieces which you have placed are in the right places, Big Ears will nod his head. If any are in the wrong places, he will shake his head and those pieces will be returned to the left window. On level one there are four pieces in each puzzle, there are nine pieces in level two and 16 in level three.

NODDY'S PAINT POT

Noddy's Paint Pot is an art package which has been designed so that even the youngest child can enjoy it. It contains most of the major functions found in dedicated art packages, so it will give children the confidence to use such utilities at an early age.

Noddy's Paint Pot is presented on two screens: the Drawing Screen is the active drawing area. By selecting a drawing function (from those represented by the large icons in the centre of the Menu Screen) the screen will rise to reveal the Drawing Screen. To return to the Menu Screen children should click on the right mouse button or press the space-bar. When on the Drawing Screen, each of the functions are controlled by pressing the left mouse button (or Enter or Return) to start and repeating this operation to stop it.

The left mouse button must not be held down while children are attempting to draw, this will have no effect. This is because young, small, hands find it difficult to hold down the button and draw at the same time.



The drawing screen of *Noddy's Paintpot*: kids will have hours of painting fun with this demo.

The active colour can also be altered using the Colour Strip on the Drawing Screen. Additionally, a fill pattern function is available which uses the currently active pattern. This can be changed by clicking on the arrows either side of the pattern selector box on the top left of the Menu Screen.

Noddy's Paint Pot contains a number of characters and objects which can be pasted on to various pictures. These can be scrolled through by clicking on the arrows that are either side of the selection strip. If children click on any of the three visible objects or characters the program will move to the Drawing Screen with that object selected. This can be pasted anywhere within the picture by clicking on the left mouse. Happy painting!

HOW TO CONTROL

The menu screen contains the various icons from which this program is driven...

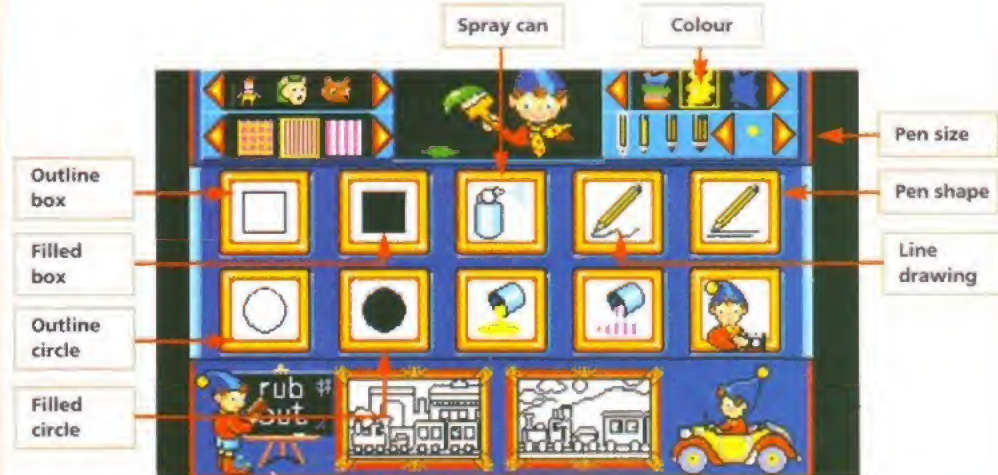



WICKED TOYS FOR WICKED BOYS

Our A1200's are also available with fully prepared and formatted internal IDE hard disk drives. Please add the following prices for the size of the disk drive that you require:-

20M_B	£110
40M_B	£179
120M_B	£279
240M_B	£449
330M_B	£579
480M_B	£879

PHONE FOR PRICES OF PCMCIA CARDS AND OTHER HARDWARE.
FOR PHONE/FAX ORDER SERVICE OR ENQUIRIES
Tel. (0736) 331039

FOR MAIL ORDER SERVICE:-
SOFTWARE DEMON LTD.
P.O. BOX 90 PENZANCE,
CORNWALL, TR18 2SP

Please add £6.00 for postage & packaging
Please make all cheques/P.O.s payable to **SOFTWARE DEMON LTD.**,
if applicable please include your credit card No and expiry date.



THIS IS A demo of the latest Simpsons release from Accolade, this time Bart's taking on the world. The game revolves around an ill-considered foreign holiday by Homer Simpson and his family. The Coverdisk demo features just the Chinese sections of his world tour (check out the background for Bart: it's anything but straightforward). There are various sub games, some of them are very simple, others that are less so. Bart has to step in to solve the puzzles, outwit the opponents and generally save the day.

To get to the Bart demo, you have to first make a Bart disk. This is not too difficult, and should take between five and 10 minutes at the very most. See Page 7 for the exact details - once you have made a Bart disk, simply reset your Amiga and put the Bart demo disk into the disk drive. The demo will then automatically load.

You control the Bart character by means of a joystick. First, press fire to get off the title screen. Then you must select which of the five mini games you want to play. Only two of the games have obvious arcade roots - most of the games are puzzle-like and don't need fast reactions. So get going and press the fire-button to confirm your selection.

ONE SMALL THING...

There is a bug in this demo, in the Great China Wall section. If you take a bad fall (hit a dip too fast) then the game will just stop. If, however, you do not hit any obstacles then the stage can be easily completed. Both *Amiga Format* and Accolade apologise for this bug, and don't worry, it won't be in the final finished product.



If you try really hard, then you can get down to this rudder section where you find Maggie, Bart's sister. It may then be possible to escape this level if you manage to acquire enough points - sadly it's never managed to work for me though. Crawling up the rudder is the best way to go.



This is my favourite part of the demo. You have to guide Bart's skateboard down the wall, avoiding obstacles, meandering oriental types and a rather nasty fire-breathing dragon. If you hit too many obstacles, Bart can stop and the game hangs - apologies for the bug. The course is easily completed with a little practice.

Bart Simpson VS The World

ACCOLADE PAL/NTSC



The basic technique to survive and play on is to make sure you avoid all the nasties in the sub game. Jumping up to avoid dynamite is easily mastered, but crawling up the masts without being cherry bombed is not that simple. Push up to jump, fire to fire (you need to collect ammunition first) and left and right do just that.



This is a very simple game - simply move the joystick and press fire to select two cards. If the cards do not match, you lose an attempt. If they do match, your number of attempts stays the same. You have to be both lucky and skillful to get all the pairs before you run out of goes.



This is the simplest sub game of all, so no excuses for not being able to complete this one - just press fire to stop one of the reels spinning and try to get a win. It's quite skillful, but once you know the reels it becomes a bit repetitive.



There's just no way I can complete this, but this sort of puzzle has always confused me. Use the joystick to select which block you want to move, and press fire to use it. Simple in theory, the puzzle is very difficult to rearrange correctly.



Using Your Coverdisk

1. Always write-protect your Coverdisk. Move the tab so a hole is showing.
2. Copy the Coverdisk and use the copy, not the original. This may sound like a complicated task, suitable only for techno buffs, but it's surprisingly simple to do, just follow the simple instructions for copying the disk which are given below.
3. Read the instructions when using the programs.

Backing up your Disk

There are two ways of making a copy of your disk, and this is the easy one. Don't be daunted by the fact that you need to use the Shell or CLI: it's actually a lot easier than you might think.

Just follow these simple steps...



1 Load your Workbench disk. Open the disk, find the icon that says Shell or CLI and double-click on it.

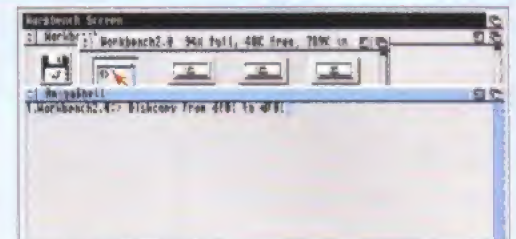

2 When the Shell window appears and the drive light is out, type in:
Diskcopy from DF0: to DF0:
and press the Return key.



3. The Amiga will now ask you to insert the 'source' disk. It means the disk you want to copy, so put the Coverdisk in the drive and press the Return key.

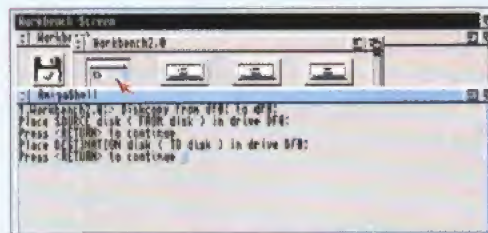

4. Wait for a while and it will read all the information off the Coverdisk, telling you how far it has got. Then it will ask you to insert the 'Destination' disk. Put the disk you want to copy your Coverdisk on to in the drive and press the Return key. Note that the disk does not need to be formatted already.



5. Put the source disk and destination disk in a couple more times when the Amiga asks for them. When it says "Diskcopy Finished" just type in:
endcli
to get out of the Shell or CLI. You may have to put the Workbench disk in again. Now your copy is ready!

DISK PROBLEMS?

If you have a problem with the disk – and you're sure the disk is in full working order – then you may need a little help. If you ring us on any Tuesday, and ask to speak to Pat McDonald, he will do his best to help you. Please understand, giving this sort of advice is time-consuming and we are very busy people, so only call if you really have to and do be considerate if we can't talk to you just then. If the problem is particularly complex it is better to send it to us in written detail. It will then be dealt with in the Workbench pages of the magazine.

BE CAREFUL!

We have done our best to check that all of the programs on the **Amiga Format** Coverdisk are simple to use and have no viruses. We cannot usually answer complex telephone queries on the software (see the Disk Problems? box) and we do not accept liability for any consequences of using the numerous programs that are on the disk.

COPYRIGHT

Unless it is specifically stated, the programs on the Coverdisks are not in the Public Domain and the copyright remains with the copyright-holder of the program.

Because some of the programs on the Coverdisks are not PD, selling or distributing them without the copyright-holder's specific permission is against the law.

Disk not working?

We duplicate nearly 500,000 disks every month. Out of all those, obviously a few will be faulty. If the disk or any of the programs will not load or run properly, there may be a problem. Don't panic!

First try using the DiskDoctor utility on your Workbench disk to rescue it before sending it off for a replacement. In-full details of DiskDoctor can be found in the user's manual that came with your machine.

However, if your Coverdisk is in fact faulty, you should send it back INCLUDING A STAMPED, ADDRESSED ENVELOPE for a free replacement within one month of the cover date to:

Amiga Format February Disk
Disk Copy Labs Ltd
Units 2&3
Omega Technical Centre
Drayton Fields
Daventry
Northants
NN11 5RT



125+

- Four ultra-sensitive fire buttons
- Ergonomically designed control handle for supreme comfort
- Auto-fire function
- Heavy duty base with strong stabilising suction cups
- +2/+3 selector connector
- 8 directional control
- Automatic centering
- High impact robust body
- Compatible with Sinclair Spectrum +2/+3, Commodore, Atari and Amstrad computers and video game systems.
- Sega Master Series version available

• **ONLY £9.99**



STAR PROBE

- Four ultra-sensitive microswitched fire buttons
- Ergonomically designed custom control handle for supreme comfort
- Auto-fire function
- Indestructible metal shaft
- Ultra-light 8 directional microswitched control
- Heavy duty base with strong stabilising suction cups
- +2/+3 selector connector
- Automatic centering
- High impact robust body
- Compatible with Sinclair Spectrum +2/+3, Commodore, Atari and Amstrad computers and video game systems.

• **ONLY £14.99**



MACH 1

- Four ultra-sensitive fire buttons
- Ergonomically designed control handle for supreme comfort
- Auto-fire function
- Indestructible metal shaft
- Ultra-light 8 directional microswitched control
- Heavy duty base with strong stabilising suction cups
- Automatic centering
- High impact robust body
- Compatible with Commodore, Atari and Amstrad computers and video game systems.

• **ONLY £12.99**



EXTERMINATOR

- Two ultra-sensitive fire buttons
- Ergonomically designed control handle
- 8 directional control
- Automatic centering
- Heavy duty base with strong stabilising suction cups
- High impact robust body
- Compatible with Commodore, Atari and Amstrad computers and video game systems.

• **ONLY £6.99**



TURBO FIGHTER

- Ergonomically designed for supreme comfort
- 2 ultra-sensitive fire buttons
- Heavy duty base with strong stabilising suction cups
- Robust clamp for secure desktop mounting
- 8 directional control
- Automatic centering
- High impact rugged body
- 'X' and 'Y' axis trim controls
- Additional Joystick B 'Y' axis control (for PC users only)
- Analogue to digital converter included for compatibility with PCs as well as Amiga, C64, Atari ST, Amstrad CPC etc.

• **ONLY £49.99**



CHEETAH

BUG TIME



THE BUG

- Ergonomically designed body for supreme comfort
- Suitable for right or left hand
- 2 ultra-sensitive microswitched fire buttons
- Auto-fire function
- 8 directional microswitched control

- Indestructible metal shaft
- Automatic centering
- +2/+3 selector connector
- Compatible with Sinclair Spectrum +2/+3, Commodore, Atari and Amstrad computers and video game systems.

• **ONLY £14.99**

THE NEW GENERATION IN JOYSTICK TECHNOLOGY

THE TORTOISE

- Three ultra-sensitive fire buttons
- Ergonomically evolved control shell
- Automatic centering
- Heavy duty body with strong stabilising suction feet
- 8 directional movement
- Cage sold separately
- Versions include ZX Spectrum, 16K, 48K, 128K, (interface sold separately), +2, +3, C64, Amstrad, Atari, Sega and Nintendo.

• **ONLY £9.99**

- 12 month warranty on all products shown.
- Older computers may require interfaces and/or adaptors - not included.
- Prices include VAT, postage and packaging.
- Dealer enquiries welcome.
- Cheetah products available from branches of

 CURRYS SUPERSTORE
 Harrods
 WHSMITH
 TOYS R US

High Street stores and all good computer shops.

CHEETAH

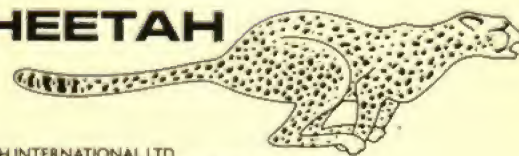

CHEETAH INTERNATIONAL LTD
 Cheetah House, Bedwas Business Park, Bedwas, Gwent NP1 8DU
 Tel: 0222 - 867777 Fax: 0222 - 865575

All specifications and prices subject to change without notice.

Actual screen. Not simulated.

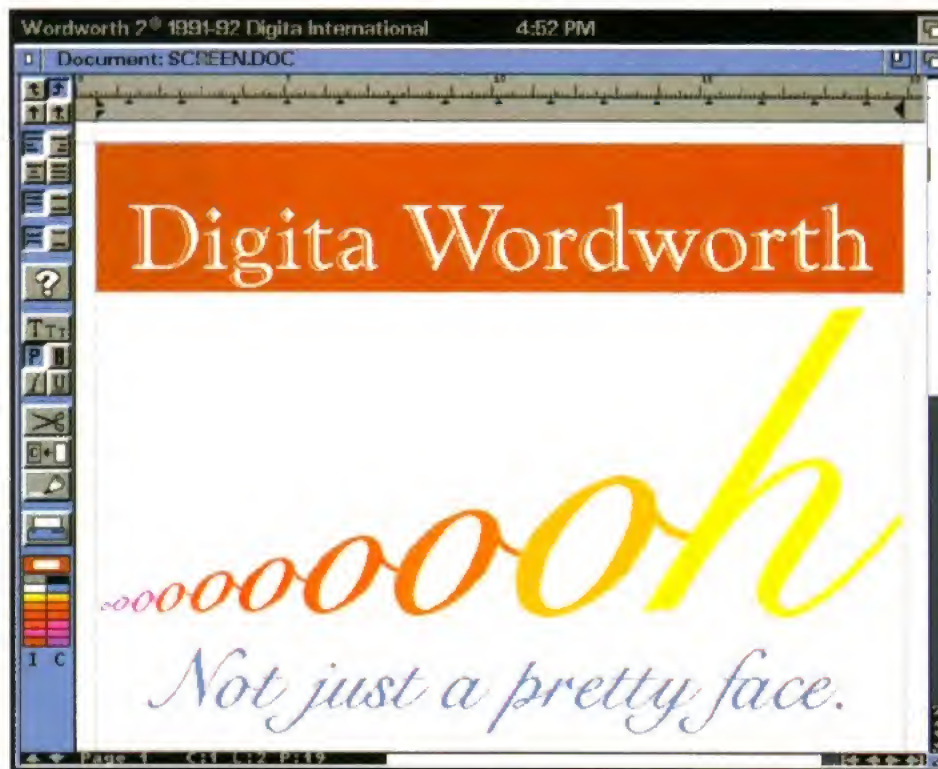

If you want to take a closer look at the new Wordworth
call 0395 270273, or write to
Digita, FREEPOST, Exmouth EX8 2YZ ENGLAND

Actually, you're looking at the new Digita® Wordworth® version 2.

It's the revolutionary Intellifont® technology which produces on-screen fonts at sizes from 3 to 800 points!

Wordworth comes with 17 genuine Agfa® Compugraphic fonts, which are just about the best quality around.

Best of all, Wordworth prints silky smooth fonts at the highest possible resolution of your printer.

Which means, in human terms, unbeatable print quality. Just click the icon on the tool bar and in seconds you'll be printing jagged-free letters and graphics.

But, there's more to new Digita Wordworth than just pretty fonts...

New features include • columns • tool bar • indexing • table of contents • endnotes • improved mailmerge and file support • bookmarks • text sorting

• improved search and replace • hotlinks. In fact, there's over 100 new features and improvements.

So, if you want to print the sharpest possible letters around, trade up now from any Amiga word processor for just £59. But hurry, this is for a limited period only.

Digita Wordworth, what you see is what you get—the power to present.



Digita International Limited Black Horse House Exmouth EX8 1JL England Telephone 0395 270273 Facsimile 0395 268893

- A member of the Digita group -

Digita, the Digita logo, and Wordworth are registered trademarks of Digita Holdings Ltd. Scalable type outlines are licensed from Agfa Division of Miles Inc. Agfa is a registered trademark of Agfa-Gevaert, AG. Intellifont is a registered trademark of Miles Inc. Digita Holdings Ltd acknowledges that all registered and other trademarks used in the text of this advert are the properties of their respective companies. Whilst every care has been taken to ensure that the information provided in this advert is accurate, Digita Holdings Ltd cannot be held liable for any errors or omissions that may have occurred. Sold subject to standard conditions of sale E and OE.

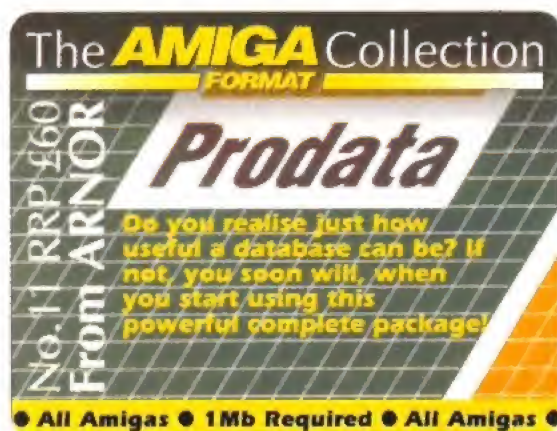

Prodata

Classify your things; that's the message from **Amiga Format** this month. So join **Andy Hutchinson** as he guides you through the wonderful Prodata database program and still manages to say: "Now where did I put Vanessa's address?"

GETTING STARTED

Insert the disk in your Amiga. The Amiga Format coverdisk logo will appear just as shown above. Double click on this icon and a window will open showing two files. Double click on the PD Config file and follow the installation procedure. Make sure that you back up your disk first; turn to Page 10 and follow the instructions there.

THE PROBLEM WITH things is that they tend to get either lost or mixed up. Records go missing, prized comics get thrown out by mums, valuable stamps end up on envelopes, butterflies get eaten by small children, safari parks go bankrupt and as a result people end up getting frustrated. The loss (either temporary or permanent) of things accounts for more human suffering than either oil or religion. Thank God then for databases.

Databases enable you to store information about things. They then enable you to sort that information in any number of wonderful ways and this then allows you to hunt quickly for individual snippets of information. Databases are really wonderful programs because while they won't stop you losing all those things in the first place, they will enable you to keep track of your valuable collection, be it record or invaluable phone numbers.

Study the form

Once you've installed *Prodata* on hard drive (see Page 16) or floppy disks you can run the program and start creating your first database. Double click on the *Prodata* icon and the program will start up. The first order of the day is to actually set up your database and to do this you'll need to think about your needs.

Let's say that you've decided to have an address book. The information you're likely to want to include within the database are things like: name, street, town, telephone number, company and comments. With this kind of information stored within your catalogue you will be able to search for people according to any of those classifications.

This is the beauty of the database. If you stored all your information on cards you'd have to trudge through each and every one of them looking for the appropriate pieces of information. If, for example, you needed to know the names of all your friends in a certain town you could do it extremely easily.

So, we've decided what we're going to catalogue and what aspects we want to include about all the individual items within that catalogue. The next step is to actually create your database from scratch and set up the card template into which you'll insert all the pertinent information.

On the *Prodata* Coverdisk you will find a file called 'addrfile.pfd'. Insert the *Prodata* disk and then



So! What does Vanessa Paradis have to do with databases? Well imagine you had her address, would you want to write it down where anyone might discover it, or would you try and memorise it, and risk forgetting it? Far better to store it safely in a computer database, where you can protect it from prying eyes with a password. By the way if you do have Van's address (or even just her phone number) send it to us and win an extra-special prize.



Choose the Alter/create database option and click on the Edit field names item. You should see eight items labelled Field 1 - 8. Fields are the individual classifications used for that particular catalogue.

click on Open database by moving the bar up and down with the cursor keys or by pressing O. Now just press Return and a catalogue of all the files and directories on your disk will appear. Choose the demo file 'addrfile' by pressing Return when the black menu bar is over it.

Choose the Alter/create database option and click on the Edit Field names item. You should see eight items labelled Field 1 - 8. Fields are the individual classifications used for that particular database. So in our example one of the fields covers surnames and one telephone numbers. You can have an almost unlimited number of fields within each of your templates but it's best to keep things as simple as possible.

Reach out and classify somebody

Hit the Esc key twice and you'll get back to the main menu. Hit the D key to enter the Display/edit records

Continued overleaf



The General options page enables you to set global parameters which determine how the catalogue behaves. Most important option is the maximum number of fields.

section of the database and you should see the entry for Arnor who created Prodata. Click the left and right cursor keys and you'll see entries for other non-existent people.

Click the cursor keys until you see an entry for James Brown. Hit the E key and you'll be able to modify the contents of that card. Move the bar down to the Address 4 field name and type in 'USA' and then hit Esc. That information will be saved to disk automatically by Prodata. Every time you make a change like this the program will update the database, there's no need to save the file at all.

Now hit the A key and you'll be able to add your own entry. Type in 'Amiga Format' then press Return twice, followed by '30 Monmouth Street', 'Bath', 'Avon', Return, 'BA1 2BW' and finally '0225 442244'. Press the Esc key and this new card will be saved to the address book file.

Let's say you want to track down an item of infor-



Using the demonstration database which is included on the disk, you can enter new names and addresses. Here we've entered a particularly fine magazine's name.

mation. Obviously, clicking through each card in succession is a tedious and slow method of finding the right piece of information. Press the F key and type in 'Brown'. Prodata will search for the appropriate card and display it on-screen. These are the basics of manipulating a stack or file of cards. Experiment with the Display/edit records page and you'll find that it's very easy to zip around your data.

Make an impression

Right, you're now familiar with the basic mechanics of databases. However, it's unlikely that you'll be able to use the demonstration file for all your needs, in which case you'll need to create your own templates. This will enable you to set up the card the way you want it with the fields laid out in a manner suitable for your data storage.

Creating a template is an easy job with Prodata. We do suggest, however, that you sit down and work

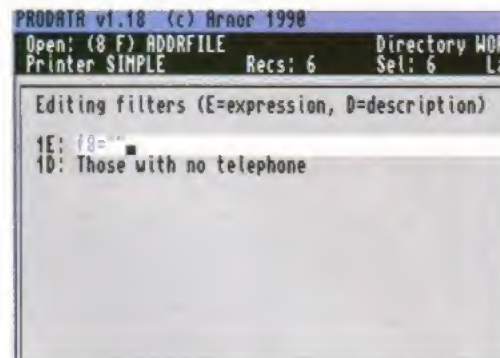

The filter option is simply a flashy way of sorting files into a format you're happy with. This filter will search for people without a telephone number entry.

out exactly what you want the cards to read. It's all too easy to get over-enthusiastic about this sort of thing and include fields for all sorts of bizarre information which you won't need. The simpler the card the quicker it'll be both to enter information and to read it.

Call up the Alter/create database option by pressing the A key and then click on the Create New database option by pressing N. Give your database a name, press Return twice and you can now start naming your fields. For instance, if this was an address database you'd type in 'Name'. Continue entering all your fields and when you've finished hit the Escape key.

In order to change the actual layout of the card you need to create your own. Hit the N key and you'll enter the layout-modification screens. If your layout is brand new (and let's face it most of them will be) then you can change global attributes as well. The first option enables you to name the layout (say: Tax Form), the height (how many lines deep the layout will be), the

Key strokes

←	Move cursor left one character.
→	Move cursor right one character.
CTRL ←	Moves cursor to start of field.
CTRL →	Moves cursor to end of field.
DEL	Deletes the character under the cursor.
CTRL DEL	Deletes all characters before the cursor back to the start of the field.
CTRL-E	Deletes from cursor to the end of the field/text.
CTRL-A	Alternates two characters. 'teh' can be changed to 'The' by positioning the cursor on the 'e' and using this command.
CTRL-/	Converts the character under the cursor to upper case.
CTRLA	Converts the character under the cursor to lower case.
CTRL-TAB	Toggles between Insert and Overwrite mode.
CTRL-I	Insert line at cursor position.
CTRL-F3	Deletes line under cursor.

Sorting operators

+	plus	lwr	convert string to lower case
-	minus	not	logical negation
!	logical negation	sdate	convert number to short date
~	absolute negation	upr	convert string to upper case
abs	absolute value	*	multiplication
datenum	convert date to number for calculation	/	division
frac	fractional part of	div	integer division
int	integer part of	mod	remainder from integer division
isdate	test whether string is a valid date	\$+	string concatenation
lsum	test whether string is a valid number	round	round to no. of decimal places
ldate	convert number to long date	<	less than
len	length of string	>	greater than
		<=	less than or equal to
		>=	greater than or equal to
		<>	not equal to

Setting up base

Setting up a database is easy, and so is setting up a sort (filter) to check through your database and pick out certain records. Here's how to do both, in just seven simple steps.

When the sort conditions which you've set up are 'run' they create a kind of sub-database with all the special card entries and if you wish this can be saved off into its own file. Thus if you searched for all your friends who lived within a 30 mile radius of your home, you could create a new database called Local Friends.

To create a filter, simply click on the field name and then enter a condition. You can chain conditions together in exactly the same way as you chain together formulae in simple equations.



Right, with our database prepared it's time to set up a filter. First we have to select which field it is we want to be filtered.



The index option enables you to control the order in which the cards are displayed. You retain complete control over the index...

What's more you can have any number of indexes stored away on disk for later retrieval or you can create a brand new one.

left margin (how many characters in from the left of the screen the data will appear), the top margin (how far down from the top of the screen the data will appear), the header margin (used when printing to determine the words which appear at the top of each sheet), the footer margin (how far up the screen the text starts), the page length (how many lines long in total a page is), the records per page (used when printing), the attributes set and the protection level. When you're happy with the physical attributes, hit the Esc key and you'll enter the modification screen.

Filtering information

Right, well so far we've found out that databases are awfully good at storing lots of information in the form of cards. We've found out that these cards can be accessed in any particular order we fancy and that actually entering all the data is an extremely tedious job. However there are other ways of reading the information in the database without looking for individual nuggets of information; we can place sections of the database within their own classifications.

The dashes you see at the top of the screen represent the space which the field takes up. In the bottom left of the screen above the word Field is the name of that field. To add your other field names (address, phone number etc) simply hit the F key. If you like you can draw lines around portions of the fields by using the Line command. When you're happy with it all, hit the Esc key and you can save your layout.

This kind of searching for data is one of *Prodata's* strongest features. Let's say that you have access to the DVLC driving-licence records and that you'd like to find out whose licences will expire at the end of the year. You'd set up a search which would exclude all cards with an expiry date of less than your date. This search group could then be saved off into their own database or simply printed out.

Continued overleaf

That database jargon-busted

DATABASE: collection of cards made up of information arranged in fields.

FIELD: one item of information on a card; name, address or whatever.

RECORD: this the equivalent of one card of information.

INDEX FILE: contains all the details of where each record can be found in the data file and the order in which it is displayed.

CONFIG FILE: contains details of the way you like your database set up. Information such as default directories and screen colours will be found in here.

PARAMETER FILE: contains details of the setting for an individual database.

LAYOUT: the physical look of a card in terms of what field goes where.

FILTER: condition under which data will be displayed; people with a London telephone number, for example.

INDEX: determines the order in which data is displayed.

FOMALHAUT: a first-magnitude star in the constellation of the Southern Fish.



In order to create your own database you must first set-up the field names; that is the emblem that appears on the left hand side of a database card (name, address etc).



Then you can start entering your own card data on the fly. Here we're entering some game information about Monkey Island. You'll see that I've given it five stars.



One can also change the layout of the card from this entry screen. You do, however, have to create those layouts before hand.



Here we're performing a search on the new data. We're asking the database to look up all adventure games which we awarded five stars.



With the conditions all entered we can sift through all the files in the database. Those files that it finds are stored in their own section of memory.



Then you can peruse those lovingly sorted files at your leisure. It sure saves sifting through hundreds of individual cards.



The layout of a database is the way it looks on screen as you view it, or on paper after you've printed it out. You can place fields anywhere you want.

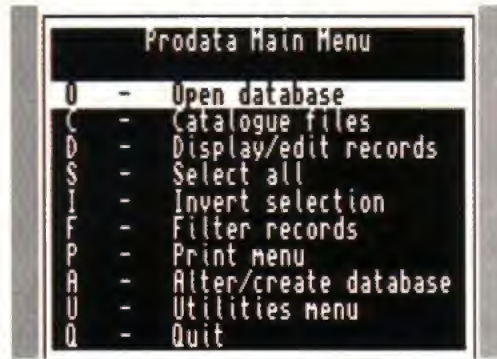

The main menu enables you to perform simple housekeeping tasks on the database, or more strenuous filtering jobs.

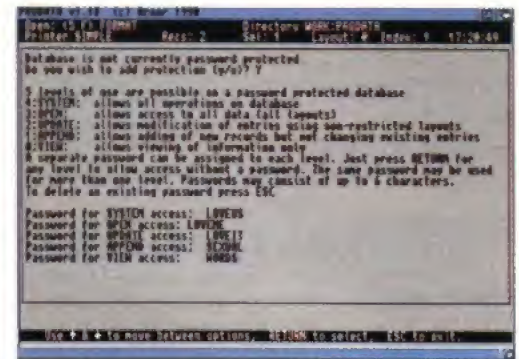

Should you wish to stop prying eyes seeing portions of your data you can set up a series of passwords giving different levels of access.

Prodata achieves this kind of search with a feature called filtering. It does this with something called an 'expression evaluator' which enables you to enter equations for searching data. These expressions are built up in much the same manner as equations and can include lots of different clauses, enabling you to get at very specific chunks of data.

Say for example you wanted to find out all the people in the database with the name Paradis. Your search criteria would be: 'Paradis' IN F1. All this is saying is: give me all those records with the word Paradis in the first field. When you set this on its way it would happily trundle through all the records checking the contents of the first field (normally the name field) and then making a note of any containing the word Paradis.

It's also possible to search your data in terms of numerical values. Let's say that your fourth field contains details of people's salaries. You could type in the filter: F5>11999 and *Prodata* would check then contents of the fifth field for all those cards with a value higher than 11999.

Just like equations, the filter expressions can be chained together to narrow down the choice. Let's say we wanted to find out all those people called Paradis who earn £12,000 a year. You'd simply type in F1='Paradis' and F5>11999. This method of narrowing down information is extremely useful because you can start off with a fairly wide search and slowly narrow all the cards down until you encounter the specific one you need.

To actually create a filter with *Prodata* you should access the Alter/create database option and then pick the Create filter option by pressing F. Each filter is made up of two lines: the actual expression and a description of that expression. To create a new filter hit the F1 key. The box on the right of the screen is a list of all the fields in your database; simply pick the field you'd like to perform the search upon.

The line 1E or 2E will now say something like F3. If you want to make a very specific search then enter

an equals sign. Now if you want to search for text enter some quotation marks and the text you're looking for. If you're searching for a numeric value then simply enter that number. You'll now have a line which reads something like: 2E: f3='Amiga'. All you have to do now is enter your own description of that filter which will appear when using it.

You can continue down the list entering as many filters as you want. These will all be saved with the actual database file so you don't have to keep re-entering them every time that you want to make a search. If you're unhappy with your filter then just hit CTRL F3 and the line will be deleted. The list of operators you can use within the expression evaluator are listed on Page 14.

You have the right to be kept in the dark

These days everyone's getting increasingly suspicious of the amount of data stored on databases. At any one time in this country there are about 50 computers with information about you, your family, your financial standing, your car and even your dog. Scary right? All that data is stored on programs exactly like *Prodata* and just like *Prodata* there are ways of stopping people tampering with the program.

Prodata has a nifty function built into it called protection levels. This enables you to enter up to five different levels of password protection to data and so it's possible to keep information confidential even if other people have access to your Amiga.

The passwords you create can be assigned to different layouts of card. This feature means that it's possible to create several different kinds of layout for every database, each with different kinds of information included on them. For instance, one might simply show names and addresses, while another might also show a person's credit rating.

For each password which you assign you can set one of five levels of protection. These are a numeric code and are:

- 0: View - enables you to view data only.
- 1: Append - enables you to add data, but not to edit existing data.
- 2: Update - enables you to edit as long as the layout is non-restricted.
- 3: Open - enables you to access all data
- 4: System - enables you to access all areas and operations.

Mine's a print please

Of course it's all very well having oodles of lovely information stored on your Amiga, but what if you want to make the information available to a wider circle, then you'll need to make a hard copy with a printer. Fortunately, *Prodata* has an extremely flexible print-out system which enables you to produce well-designed card information quickly and easily.

Prodata uses printer drivers in exactly the same way as a word processor does. These are add-on programs which contain information specific to a particular type of printer. These are needed because printers are set up in different ways according to their type; laser printers need different information to that of dot-matrix printers.

To print out a database all you then have to do is select the appropriate driver (it'll be called something akin to the name of your printer) and then press the P key to send this to your printer. You can also print to screen or file. The latter option is useful because it creates one amorphous lump of data which you can then load into other programs such as word processing for further editing.

Balance of payments

Computer programs are normally very insular entities, and they rarely ever talk to other programs and when they do it's in a different language. Thankfully, though, *Prodata* is conversant in quite a few different languages and so it can chatter happily to all manner of different programs.

Exporting data is simply a case of choosing exactly what data you wish to transfer to the file and then the format you wish that file to take. You don't have to send the entire contents of all your cards to the program. This is useful if you're creating a hard copy of an address book when there's no need to include either phone numbers or comments.

Importing data is best used with ASCII files. These are files which contain only textual information; all the control codes which normally litter a file have been stripped. One useful feature of the importing process is that you can selectively import data, meaning that each piece of information pulled off the file can be assessed for relevancy and importing and exporting of data is carried out from the Utilities menu. Take control of your things and get organised!

Hard drive installation

If you're one of those increasing numbers of people with a hard drive in or outside your Amiga, then you're going to have to rename the Coverdisk before you can run the installation process. Here's the drill.

- Back up the Coverdisk (see Page 10).
- Click on the disk icon.
- Pull down the menu option RENAME from under the ICONS window and call the disk: Prodata-Program-Disc.
- Enter the CLI shell which is usually lurking within your system file.
- Type in 'CD DF0:' and then Return and then 'EXECUTE HDINSTALL dh0:'
- The configuration program will now run and you can set the program up the way you want it.
- Make yourself a large mug of coffee. You've earned it.



ALIEN 3™

ALIEN 3 TM & © Twentieth Century Fox Film Corporation



CHEETAH

JoySticks from
the CharacteriStick range



BART SIMPSON™



CHECK IT OUT, MAN!

THE SIMPSONS TM & © 1992 20TH C. FOX F.C. All Rights Reserved.

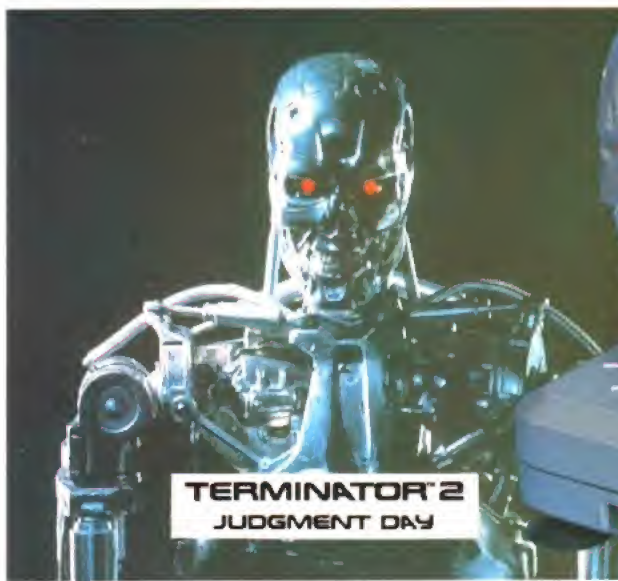

TERMINATOR 2
JUDGMENT DAY

TM & © 1992 CAROLCO All Rights Reserved. Unauthorised Duplication is Strictly Prohibited.



BATMAN

TM & © 1992 DC Comics Inc. All Rights Reserved.



BATMAN RETURNS

TM & © 1992 DC Comics Inc. All Rights Reserved.



Features include

- Officially licensed products
- Highly sensitive light touch fire buttons
- Full 8 directional control
- On-table or in-hand operation
- Heavy duty base with strong stabilising suction cups
- +2/+3 selector connector
- 12 month warranty
- Prices include VAT, postage and packaging
- Dealer enquiries welcome
- Cheetah products available from branches of:

BEATTIES MODELS & HOBBIES
JOYS & GAMES

- Argos**
- Dixons**
- John Menzies**
- Tandy**
- CURRYS SUPERSTORE**
- Harrods**
- W H SMITH**
- TOYS R US**
- VIRTUAL REALITY**

Versions compatible with

- Nintendo NES (£14.99)
- Sega Master System (£12.99)
- Sega Mega Drive (£14.99)
- Sinclair Spectrum +2/+3 computers
- Commodore computers and video game systems (£12.99)
- Atari computers and video game systems (£12.99)
- Amstrad computers (£12.99)
- Older computers may require interfaces and/or adaptors - not included.

CHEETAH INTERNATIONAL LTD
Cheetah House, Bedwas Business Park,
Bedwas, Gwent NP1 8DU
Tel: 0222-867777 Fax: 0222-865575

High Street scores and all good computer shops, or direct from Cheetah.

CHEETAH
the most innovative
joystick company in the world

TOO OLD?

TOO BAD.

Are you 18 or over? If so don't waste what little energy you've got left reading this. This is a cashcard account that lets you make the most of your dosh while you're still young and fly enough to enjoy spending it. It has some wicked advantages, such as plastic that gives you 24 hour access to your funds and an interest rate that's totally awesome. So as long as you're 11-17 years old, get yourself (and a tenner) down to your local Britannia branch. Sharpish.



ONCE YOU'RE 18, YOU'RE PAST IT.

GOOD NEWS: AMIGA FORMAT TO DROP IN PRICE

Bad news: we will be dropping the *Amiga Format Collection* series of complete Coverdisk programs. From next issue, *Amiga Format* will cost a mere £3.25 per copy but will feature only one Coverdisk.

We've decided to do this mainly because the response from readers over the Collection programs has been dwindling somewhat. If you read the magazine regularly you will already have built up quite a collection of free programs and, frankly, we're beginning to run out of options for other programs.

Sadly with the cost of printing nowadays we can't afford to revert to our original £2.95 price tag, which we'd held from Issue One way back in August 1989 – if we'd kept up with inflation it would be closer to £3.50 now.

We can guarantee that *Amiga Format* will be as good value as ever, with a packed magazine and an exciting Coverdisk, and it's worth pointing out that we will do the odd one-off issue with a complete program on when we think it's appropriate. More treats and goodies!

FUTURETECH CONSUMER ELECTRONICS LIMITED

In the issue of *Amiga Format* for January 1993, in an article headed 'Firm's collapse leads to reader appeal, it was implied that Futuretech Consumer Electronics Limited of Newport Pagnell ("Futuretech") had ceased to trade.

Amiga Format is now satisfied that the above statement is wholly unfounded and desires to express its regret to Futuretech Consumer Electronics Limited and to apologise to them for any embarrassment and inconvenience caused.

Amiga Format is Going Live!



THE WORLD'S MOST popular Amiga magazine (yes, that's this one) has bowed to public pressure to organise its own show and exhibition in the spring. The event will be called Amiga Format Live! and will take place at London's Earls Court 2 in May.

The show build on the success of 1991's hugely exciting World of Commodore, which was sponsored by Amiga Format, and the Amiga Shopper Show which was run by our techie sister magazine. All manner of events are planned, many of which will be unlike anything ever seen at a computer show before.

The core of Amiga Format Live! will be stands run by many of the leading Amiga software and hardware companies, with all their kit there in action for you to see and buy. There will also be an immense games arcade, in which you can experience (and even play) all the big Easter releases from the world's major games producers.

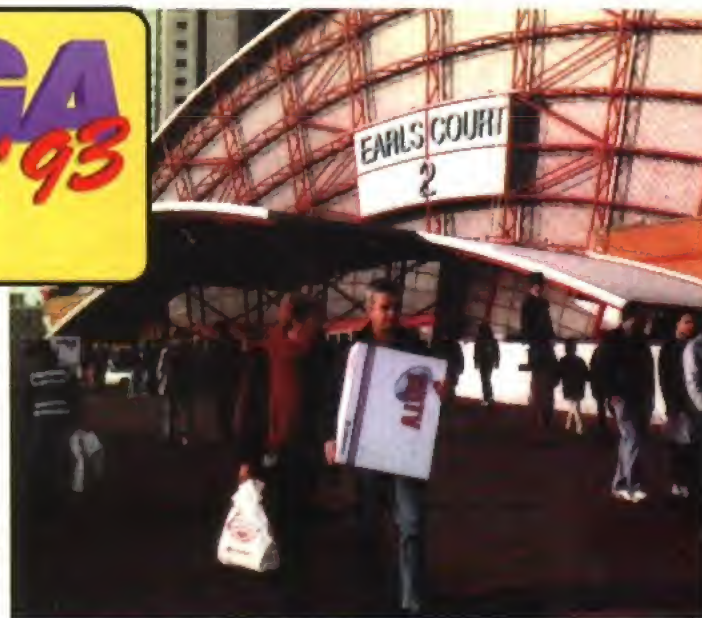

The World of Commodore Show – our previous successful Amiga event.

For further details you will have to wait until next month, but rest assured that we are planning carefully to make it the most exciting event of its kind ever – and it's only for Amiga owners! In the mean time, you can get your chance to make sure that whatever you want to see features at the show by turning now to Page 25 and filling in the form: you may even win a prize!

DPaint leads A1200 arrivals

ELECTRONIC ARTS ADAPTED version of Deluxe Paint IV, which is identified by the tag 'AGA' on the end of the name, will go on sale in mid-January and is expected to be the first example of A1200-specific software to go on sale.

The AGA version works in both 256-colour mode and in the new 8-bit HAM mode, which means you can paint in 262,000 colours. A test model we've seen looked a little slow in the maximum-colour mode but the effects of gradations of colour are just stunning: a slight disappointment is that the palette remains the same, where a new way of selecting colours might have been more appropriate.

Gremlin's A1200 Zool may just pip it to the post: the enhanced version is expected to go on sale any day now. It looks quite extraordinary, the programmers having used the extra bitplanes to put masses of huge, colourful objects into the background instead of the simple copper colour-shading.

Programs already on sale that support the new colour modes include ASDG's Art Department Professional image processing program and their Morph image-distorting program, reviewed last issue.



The new, enhanced version of the Amiga's top paint program will enable you to use 262,000 colours on the screen.



The new, enhanced version of the Amiga's top paint program will enable you to use 262,000 colours on the screen.

Perhaps more exciting is that next month will see the release of the first 256-colour DTP package – and it's one of the cheapest on the market.

It's Gold Disk's third version of Pagesetter, which they are putting out at the experimental cut-down price of only £49 via Silica (081 309 1111). Considering that

you get not just a DTP layout program but also a paint package and a word processor for your money, it seems like quite a deal.



Amiga world goes red-nose crazy!

There's only a month before it's Comic Relief time again, and the better-off start digging into their pockets to help the world's less-fortunate. This year, even gamers are expected to take part.

In a totally-applaudable move, Ocean Software have combined their games-making skills with the Comic Relief cause, and are about to release a stonking new game called Sleepwalker as part of the fund-raising exercise. The game will also feature in a special Comic Relief A1200 Red Nose pack which Commodore have put together.

Sleepwalker is a massive platform game where you play the part of a dog who is trying to protect his sleepwalking owner. You rush around trying to prevent your master from walking off the edges of buildings, getting run over by cars and heaps of other deadly accidents. Throughout the game you're treated to some glorious graphics, plus sound effects created by none other than Lenny Henry himself.

As well as donating a large portion of the profits from the sale of Sleepwalker to Comic Relief (around £5 per copy sold), Ocean have organised

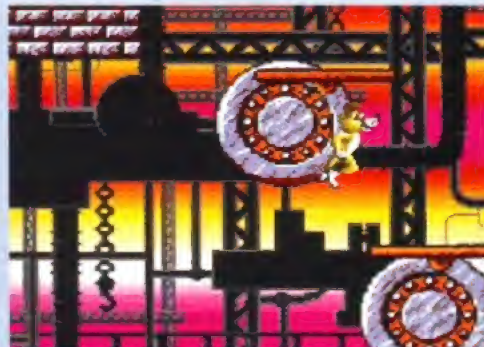

The first ever official Comic Relief game, in which you play a dog who must save his sleep-walking master.

a national challenge in which you can get involved. Each copy of Sleepwalker contains a sponsorship form which gamers can use to become part of Red Nose Day.

All you need to do is get yourself sponsored and play the game – your sponsors pledge cash for your high scores, and hopefully heaps of extra dosh will be winging its way to the needy as a



Guiding a zombie-like human being through terrors and traps isn't always an easy task – but it's in a good cause!

result of a few hours playing games.

A grand final in Central London has been organised for Red Nose Day itself (March 12th), and challenges are being held in retail shops around the country prior to this. Now that's what we call fun-raising! Look out for copies of Sleepwalker on the shelves in late January – and then get some practice in before the big day.

Seikosha pop up with bargain colour 24-pin



Seikosha's new 24-pin colour printer is claimed to be the cheapest ever to go on sale, which could rapidly make it a very popular item.

PRINTER MANUFACTURERS SEIKOSHA have just announced a brand new 24-pin colour printer for the ridiculously low price of £249. This is claimed to be the lowest price at which a colour 24-pin dot matrix machine has ever gone on sale; the actual on-sale price will no doubt be substantially less than this RRP.

The new machine is the SL-95, and it's capable of speeds up to 240 characters per second in super draft mode, or 64 cps in Letter Quality mode. It offers Epson compatibility and a standard parallel interface, making ideal for the Amiga. It's also the only printer in its class to offer a 43K buffer and nine totally separate fonts built-in. The new SL-95 hits the shops in January and it comes with a full 12 month warranty. For more information contact Seikosha on 0753 685873.

Future
PUBLISHING

- Launched in 1985
- Now over 125 staff
- 10 national newsstand magazines
- Market leader in computer titles
- Exciting launch plans
- Britain's fastest-growing publisher

WANTED! Writers and more besides

Salaries depending on all sorts of different things...

We're looking for a number of new staff members of various degrees of ability and experience. Details as follows...

Amiga Format requires at least three new people to join its amazing, fun-filled team to take the magazine to even greater heights in 1993. Exact roles have not yet been defined, so if you're interested we'd be glad to hear from you.

REVIEWS EDITOR (or similar). We need an Amiga journalist to not only write about games, but also to deal with all the software houses and 'liaise' with the people who will be writing the reviews. A strong sense of what makes a good game, good writing skills and the ability to keep everything under control are vital.

We're also interested in someone who can perform a similar role on the features and serious reviews side of the magazine. Experience in both roles could be a big advantage and all applications will be treated in confidence.

PRODUCTION ASSISTANT. Your start into the exciting world of magazines. A willingness to do some dull jobs while gaining experience and a thorough knowledge of the English language (spelling, grammar, punctuation, that sort of thing) are vital.

Write with a CV and samples of your own writing to Damien Noonan at the address below.

SILICA SPECIAL OFFER!

PUT YOUR AMIGA TO WORK!

Impressive power and ease-of-use makes business or home office computing easy and fun!

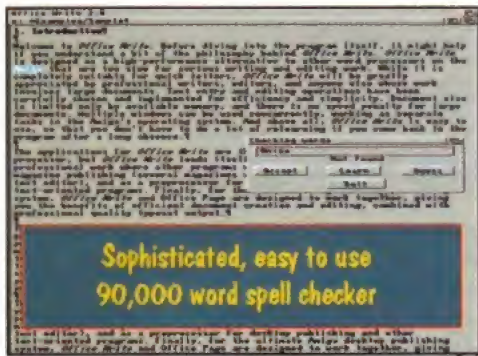

Sophisticated, easy to use
90,000 word spell checker

Ultra Fast Word Processor With
90,000 Word UK Spell Checker!



Simple User Interface

Easy-To-Use Page Layout
Creates Professional Flyers,
Ads, Newsletters And More!

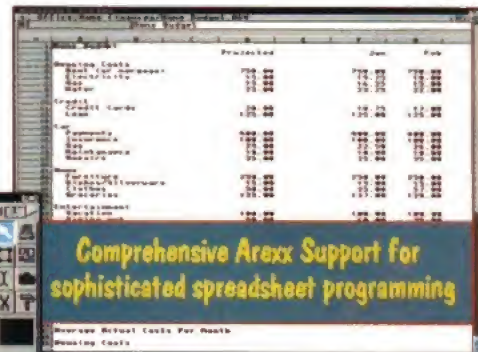

Comprehensive Araxx Support for
sophisticated spreadsheet programming

Advanced
Business
Spreadsheet
Organises
Home or
Business
Finances
Fast!

Powerful
Database
Manager
Handles Up
To 32,767
Records!



Up to 32,767 records per file

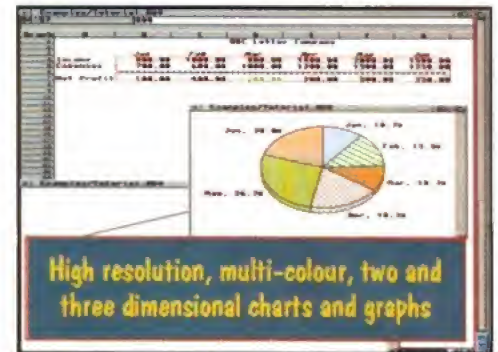

High resolution, multi-colour, two and
three dimensional charts and graphs

Graphing Module Illustrates Your Numbers
With 3-D Charts and Graphs

LET YOUR AMIGA DO IT FOR YOU WITH GOLD DISK OFFICE II Was £129.95, Now Only £49.95

Whether you're running a business or a household, Gold Disk Office gives you the power to do it better, faster, and easier.

With Office Write you'll be turning out letters and reports faster than you thought possible. And our 90,000 word "English" spell checker will keep you accurate. It also handles mail merge from Office File and links to Office Page and Office Calc.

Office Calc makes your office or home finances easy to take care of. It's a high power

spreadsheet with advanced features like ARexx support, more than 100 functions, and Lotus/Multi-Plan compatibility!

Office Graph lets you understand your numbers better using a variety of multi-colour 2 and 3-D charts and graphs. You can export your graphs for use in Office Page and more.

Office File is a powerful database that makes it easy to keep track of friends, customers, inventory and more! Use it to mail merge with Office Write or link it to Office Calc for super power!

Use Office Page to create your own professional flyers, newsletters, brochures, ads, and

more! Easy to use, Office Page is filled with professional features like AGFA CompuGraphic fonts for hi-res output on everything from dot-matrix to PostScript. Columns are a snap and you can even wrap text automatically around structured or bitmapped graphics. Office Page makes page layout fun and profitable!

THE CRITICS AGREE!

"...a package of five separate and powerful business programs that are as easy to use as they are to buy."
Amiga World

"...an impressive package of five full integrated programs that

turn an Amiga into the centre of operations of a highly productive office." - Amiga Computing

So if you want to be more productive, and make work as easy as playing games, get Gold Disk Office today! At this low special price, you can't afford not to!

Improve your productivity NOW by calling SILICA at
081-309 1111
Or stop by your nearby Silica Systems or other Gold Disk dealer!

Cheetah's mythical stick



Renowned for their range of peculiar and oddly-shaped joysticks, Cheetah announce a new device for their FuturiStick range. The ArgoStick looks as if it's a spare part left over from the latest Aliens film, but, according to Cheetah, it's been carefully sculpted to provide the ultimate in comfort and control for the most serious of games players. The main trigger button is carved into the shape of a skull and there are several other fire buttons on the stick. There's also an autofire mode to save you from actually having to do anything in shoot-em-ups. The ArgoStick is available in two versions, a high-tactile version for £12.99 and a fully micro-switched version for £14.99. Contact Cheetah on 0222 867777 for more details.

Art for clip's sake

Artworks, the DTP clip art specialists, have just released three new disks of art for the Amiga. Each disk has a specific theme and contains between 115 and 270 high quality black and white IFF bitmaps drawn especially for the Amiga by professional artists. The three topics are Prehistoric Life, Weddings and Family Occasions, and Signs and Symbols 2. Each disk costs £6.99, or all three can be obtained for just £18.00 from Artworks (0469 588138).

CDTV drives harder

ZCL/Calculus announce the release of their new CDTV External DataPac, a rather neat black 65 Mb hard drive suitable for upgrading any Amiga CDTV. The package comes complete with plug-in SCSI controller card, Workbench 1.3 and installation disks and manuals, and all necessary cables and connectors. The kit costs £349.99. Alternatively, you could supply your own hard drive unit and buy just the CDTV SCSI adapter separately for the reduced price of £99.99. Contact ZCL/Calculus on 0543 251275 for more details.

Unleashed: first A1200-booster

Power-hungry A1200 owners will be glad to know that the first bona fide A1200 expansion is here already. The Microbotics MBX1200 is a 32-bit memory upgrade which fits in the trapdoor slot on the underside of the new Amiga. The MBX1200 comes in several configurations: with 1, 2, 4, and 8 Mbyte SIMMs installed, and a 68881 floating-point maths co-processor.

The MBX1200 board also features a socket suitable for a 25 MHz or 50 MHz oscillator which enables the newer 68882 floating-point unit to be installed instead of the 14MHz 68881 variety. Each MBX1200 board is supplied with a disk containing a few maths-coprocessor benchmark tests and graphing programs.

The performance of the 68881-based MBX1200 makes impressive reading: on average, it's 7 times faster than a normal A1200 and 22 times faster than an A500. With the 50MHz 68882 version, this average performance figure rises to 19 times faster than an A1200, and 55 times faster than an A500.



The A1200: soon to be given an extra boost in power by the addition of a card with extra RAM and an FPU.

Currently, the Microbotics board is available from two UK dealers: ZCL/Calculus (0543 251275) for: £349.99 (4Mb/14Mhz) and £449.99 (8Mb/14Mhz).

Or from First Choice Computers (0532 637 988) for: £133.00 (unpopulated/14Mhz 68881), £195.99 (1Mb/14Mhz), £252.99 (2Mb/14Mhz), £337.99, (4Mb/14Mhz), EPOA (8Mb/14Mhz), £199.00 (unpopulated/25Mhz 68882).

'Amiga still the tops' according to people who sell them

Despite the high media profiles of the Sega and Nintendo games consoles, it seems that the Amiga is still in there and fighting when it comes to sales.

A major survey of computer retailers conducted by trade magazine *Computer Trade Weekly* (CTW) reveals some interesting facts and figures, including the fact that the Amiga is the format on which the far-and-away best-selling computer game of the year –



Gremlin's Zool – the best-selling computer game of 1992.

Gremlin's Zool – was exclusively released.

CTW asked a variety of questions on matters of both opinion and fact, and many of the answers are revealing. While Kelly Sumner and Commodore were top choice for 'Hero of the year' with 18% of the vote (CTW and Sonic were in second and third). Commodore also came as runners-up in the 'Villain of the year' category with a 12% vote, beaten convincingly by the seemingly-unpopular Nintendo distributor Bandai with thumbs-down from 46% of computer retailers!

'Hype of the year' awards went to *Sonic 2* and *Streetfighter 2* (perhaps not surprisingly) in that order, while the launch of the A1200 was in third place in the

'Event of the year' awards, narrowly behind two industry-only events and one place ahead of the Future Entertainment Show, the only truly public event to get a place on the list.

The 'Best TV ad' awards went to two Sega ads and the Nintendo ad, with Commodore's Amiga Christmas ad following up in fourth – still some way ahead of all the rest and, considering that the Amiga ad has to get over the serious side of the machine, not a bad showing at all.

In one category, dealers were asked to vote on what they thought was the best-quality game of the year. While the Sega's *Sonic 2* came first, the other four titles in the Top Five were all Amiga games – Zool in second, *Sensible Soccer* in third, and *Monkey Island 2* tying for third place with *Formula One Grand Prix*.

A similar line-up was in the computer game of the year by sales category (where console games were excluded). Zool was top seller, with *Sensible Soccer*, *Monkey Island*, lemmings and *F1 Grand Prix* following up. All in all, rather a good line-up and one which shows that the Amiga is still going from strength to strength.

This month's top 30



1(1)	■	Zool	FG95%
		Gremlin Graphics	
2(6)	▲	Sensible Soccer 92/93	80%
		Renegade/Mindscape	
3(-)	New	Archer Maclean's Pool	89%
		Virgin	
4(-)	New	Road Rash	84%
		Electronic Arts	
5(5)	■	Pinball Fantasies	FG90%
		21st Century	
6(2)	▼	Putty	FG95%
		System 3	
7(-)	New	WWF European Rampage Tour	
		Ocean	18%
8(10)	▲	Humans	72%
		Mirage	
9(-)	New	Premier Manager	87%
		Gremlin Graphics	
10(-)	New	Nigel Mansell	55%
		Gremlin Graphics	
11(12)	▲	Monkey Island 2	FG95%
		US Gold	
12(7)	▼	Campaign	79%
		Empire	
13(4)	▼	Lotus 3: The Ultimate Challenge	
		Gremlin Graphics	76%
14(-)	New	AV8B Harrier Assault	60%
		Domark	
15(8)	▼	Jimmy White's Whirlwind Snooker	FG91%
		Virgin	
16(-)	New	Shuttle - Space Flight Simulator	
		Virgin	70%
17(13)	▼	Civilization	FG94%
		Microprose	
18(14)	▼	Fire and Ice	89%
		Renegade/Mindscape	
19(16)	▼	Formular One Grand Prix	FG92%
		Microprose	
20(3)	▼	Assassin	85%
		Team 17	
21(-)	New	Curse of Enchantia	62%
		Core Design	
22(21)	▼	PGA Tour +	Comp
		Electronic Arts	
23(-)	New	Dream Team	Comp
		Ocean	
24(17)	▼	Legend of Kyrandia	87%
		Virgin	
25(-)	New	Lemmings/Oh No! More Lemmings	Comp
		Psygnosis	
26(-)	New	Indiana Jones - Fate of Atlantis	FG92%
		US Gold/Lucas Arts	
27(15)	▼	Graham Taylor's Soccer Challenge	82%
		Krisalis	
28(24)	▼	Fireforce	71%
		ICE	
29(-)	New	Sabre Team	87%
		Krisalis	
30(29)	▼	Eye of the Beholder 2	FG91%
		US Gold	

A race for more Humans

If you've already completed Mirage's recent puzzle'n'platformer Humans, don't despair. Mirage are due to release a new data disk called Humans - the Jurassic Levels this month. The disk is available separately for £19.99, or bundled with the original Humans game for £29.99.



Humans - lots of new levels of this really rather enjoyable puzzle game are on the way soon.

Virgin kicking off next

Shock news this month is that the long-awaited Kick Off 3 by Dino Dini is not going



Kick Off - arguably the finest football game ever and soon out in its long-awaited third version.

to be published by Anco, the software house responsible for the previous incarnations of this massively-acclaimed football hit. Dini has recently signed to Virgin, and will instead be creating his new football masterpiece for them. Due to copyright reasons the new game cannot be called Kick Off 3, and is likely to be known as Goal, but it will essentially be Kick Off 3 in all but name. Goal is due to be released in the spring of this year, and we'll bring you a full review as soon as it's ready. In the meantime, Neil Jackson (who's managed to grab a sneak preview on the sly) can assure anxious fans that the game is already looking better than Sensible Soccer and is immensely playable, even in its half-finished condition.

Giger bites in Dark Seed



Dark Seed - the graphics are by the famous Alien artist HR Giger, digitised and looking great.

We've been waiting for it for months and suddenly it appears just a few days too late to make it into this month's review section. DarkSeed from CyberDreams is the game in question, and it's one hell of a peculiar affair. Featuring plenty of digitised artwork by the famous Aliens artist, H. R. Giger, DarkSeed is no ordinary adventure game. For a start, the Amiga version runs in interlace mode, which makes for highly-detailed (if a little flickery) graphics.

The game's plot is also a bit out of the ordinary. It follows a familiar horror-story plot, where the new owner of an old house finds out that everything's a little on the wierd side. DarkSeed follows the progress of

this unlucky owner as he attempts to find out why all these strange and sickening Giger aliens keep appearing in his living room.

Graphically stunning, and certainly the oddest game we've seen this year, DarkSeed uses a digitised main character in a game style similar to that of Monkey Island, only more malevolent. It's probably the sort of game you'd only want to play through to the end once, and then forget, but it's still something worth adding to your collection, just for the amazing graphics. We'll bring you a full review in next month's Amiga Format, as soon as we've worked out what it's actually all about.

AMIGA FORMAT *Live '93*

HAVE YOUR SAY IN WHAT HAPPENS ON THE DAY!

Amiga Format Live '93 is happening in May at Earls Court 2. It's going to be the event of the year for all Amiga owners – a show organised by the best Amiga magazine in the world, exclusively for Amiga owners all over the country.

But there's one very important thing that will make it a success – and that's you. What we'd like to do is offer you, the readers of the magazine, the chance to have a say in what goes on at the Show. If you could take a few moments to fill in the questionnaire, you could win a free pair of tickets and we can make sure that everything you want to see at the Show will be there – as well as much, much more besides!

Tear this out NOW and send it in – the first ten drawn at random will win a free pair of tickets!

1. What will be your main reason for going?

- a) To see the latest games
- b) To see the latest hardware
- c) To see the latest serious software
- d) To buy games
- e) To buy hardware
- f) To buy serious software
- g) To buy an Amiga
- h) To get some advice or technical help
- i) Other (please state) _____

2. Which of these question and answer sessions and events would you most like to attend?

- a) Meet the games programmers
- b) Meet the Amiga Format team
- c) How to... graphics
- d) How to... DTP
- e) How to... music
- f) How to... video
- g) Games-playing competitions
- h) Presentations by serious software companies

3. Which five companies would you most like to visit at their stand at the Show?

1. _____
2. _____
3. _____
4. _____
5. _____

Now just staple a piece of paper with your name and address onto this form and send it to this address...

CALL 0279 600204 FOR A FREE COLOUR CATALOGUE Special Reserve Games Club

JOYSTICKS

CHEETAH ALIEN JOYSTICK
12.99

CHEETAH BART SIMPSON JOYSTICK
12.99

CHEETAH BLG JOYSTICK
10.99

COMPETITION PRO EXTRA JOYSTICK (CLEAR BASE)
10.99

COMPETITION PRO STAR EXTRA
14.99

FREEWHEEL STEERING WHEEL (DIGITAL) FOR AMIGA SUITS MOST DRIVING GAMES
28.99

GRAVIS JOYSTICK FOR AMIGA OR ATARI ST WITH FOAM PADDED GRIP ADJUSTABLE HANDLE TENSION AND PROGRAMMABLE FIRE BUTTONS
23.99

LOGIC 4-DIMENSIONAL JOYSTICK

OVERDRIVE FOOT PEDAL TRANSFERS ANY JOYSTICK FUNCTIONS TO FOOT PEDALS. OVER 100 POINTS AND CAR STAY COMPATIBLE WITH MOST AMIGA AND ATARI ST GAMES.
16.99

QUICKSHOT 1477 PYTHON JOYSTICK
3.99

QUICKSHOT 148 INTRUDER JOYSTICK
12.99

QUICKSHOT 155 AVATAR JOYSTICK
12.99

QUICKSHOT 123 STARBUCKS REMOTE CONTROLLER WITH TWO INFRARED JOYPADS
29.99

QUICKSHOT 1480 MAVERICK JOYSTICK
12.99

QUICKSHOT 1440 AVALON JOYSTICK
12.99

QUICKSHOT 1440 TURBO 2 JOYSTICK
8.99

QUICKSHOT 123 STARBUCKS REMOTE CONTROLLER WITH TWO INFRARED JOYPADS
29.99

QUICKSHOT 155 AVATAR JOYSTICK
12.99

QUICKSHOT 1440 TURBO 2 JOYSTICK
8.99

QUICKSHOT 1480 MAVERICK JOYSTICK
12.99

QUICKSHOT 1440 AVALON JOYSTICK
12.99

TROJAN LIGHT PHAZER GUN FOR AMIGA WITH BREEZY SHOOT AND CRYSTAL DESTROYER GAMES (OTHER GAMES AVAILABLE - SEE 'TROJAN' IN AMIGA SOFTWARE LIST)
29.99

MOUSE MAT MOST EXTENSION ADAPTOR FOR AMIGA OR ATARI ST (CHANGE JOYSTICKS WITHOUT NEEDING TO REACH BEHIND COMPUTER)
3.99

REDOSHIFT INTERFACE FOR AMIGA OR ATARI ST PLUGS MOUSE & JOYSTICK INTO ONE PORT
14.99

FOUR PLAYER JOYSTICK ADAPTOR FOR AMIGA OR ATARI ST
7.99

NEW - THE LATEST IN HAND-HELD ENTERTAINMENT

QUICKSHOT SUPERVISION HAND-HELD CONSOLE WITH STEREO EARPHONES, BATTERIES AND CRYST BALL GAME.
FREE GRAND PRIX GAME
39.99

ALL GAMES UNDER £10!

2 IN 1 (HASH BLOCK AND EAGLE PLAN)	7.99
ALIEN	7.99
BLOCK BUSTER	7.99
CARRIER	7.99
CHALLENGER TANK	7.99
CHIMERA	9.99
GRAND PRIX	9.99
HERO KID	7.99
HONEY BEE	7.99
OLYMPIC TRIALS	9.99
P52 SEA BATTLE	7.99
PAC BOY AND MOUSE	7.99
PENGUIN HIDEOUT	9.99
POLICE BUST	7.99
SUPER BLOCK (3 GAMES IN ONE)	7.99
SUPER PANG	9.99
TENNIS PRO '92	9.99

NEW AMIGA 1200

NEW AMIGA 1200

Workbench 3.0 AM 200

AMIGA A1200 GRAND PRIX PACK

WITH 68020 PROCESSOR, MOUSE, BUILT-IN TV MODULATOR, 2 MEG RAM, EXPANDABLE TO 4 MEG, WORKBENCH 3.0, 3 YEAR IN-HOME SERVICE WARRANTY. (MANY AMIGA TITLES ARE NOT COMPATIBLE)

FORMULA 1 GRAND PRIX
MEMBERSHIP

379.99

ALL HARDWARE PRICES INCLUDE VAT & CARRIAGE TO UK MAINLAND

WIN £2000 WORTH OF PRIZES IN THE BIG COMPETITION! FULL DETAILS IN THE NRG CLUB MAGAZINE!

CALL 0279 600204

Open to 8pm Weekdays and to 5pm Weekends

UP FOR GRABS IN OUR LATEST COMPETITION ARE AN AMIGA, 7 SUPER NES'S AND 7 MEGADRIVES WORTH OVER £2000!

PRINTERS.....

CANON BJ-10EX BUBBLE JET

34 NOZZLE, 80 COLUMN, 810 DPI, 2401 DRAFT FONT, 1 YEAR WARRANTY. A SMALL, PORTABLE PRINTER. VERY QUIET IN OPERATION YET GIVING OUTSTANDING PRINT QUALITY.

FREE PRINTER LEAD
FREE MEMBERSHIP

219.99

CITIZEN SWIFT 200

WITH COLOUR KIT 24 PIN, 80 COLUMN, 2160PSI, 9601 DRAFT FONT, 2 YEAR WARRANTY. ADVANCED VERSION OF THE WITH AUTOSIZE FEATURE AND LCD CONTROL PANEL.

FREE PRINTER LEAD
FREE MEMBERSHIP

234.99

CITIZEN 240C

WITH COLOUR KIT 24 PIN, 80 COLUMN, 2160PSI, 9601 DRAFT FONT, 2 YEAR WARRANTY. ADVANCED VERSION OF THE WITH AUTOSIZE FEATURE AND LCD CONTROL PANEL.

FREE PRINTER LEAD
FREE MEMBERSHIP

279.99

CITIZEN SWIFT 9

WITH COLOUR KIT 9 PIN, 80 COLUMN, 2160PSI, 9601 DRAFT FONT, 2 YEAR WARRANTY. A 9 PIN PRINTER WITH COLOUR FACILITY AND FULL PAPER HANDLING FUNCTIONS.

FREE PRINTER LEAD
FREE MEMBERSHIP

179.99

INK CARTRIDGE FOR BUTLER 10.99

INK CARTRIDGE FOR BUTLER 14.99

INK CARTRIDGE FOR BUTLER 10.99

RIBBON FOR CITIZEN SWIFT 24, 324 OR 348 6.99

RIBBON FOR CITIZEN SWIFT 9 OR 120D 6.99

RIBBON FOR STAR LCDR 6.99

RIBBON FOR STAR LCDR 6.99

RIBBON FOR STAR LCDR 6.99

PRINTER LEAD (PACKAGE) FOR AMIGA ATARI ST OR PC 7.99

QUEST COVER FOR 80 COLUMN PRINTER (LEAD PLY) 4.99

DISKS, BOXES ETC.

Bank Disk

3.5" DISK BOX 3.5" 100 STACKABLE
9.99

DELUXE DISK BOX 3.5" 100 LOCKABLE DIVIDERS
10.99

DISK BOX 3.5" 100 CAPACITY 1.99

DISK BOX 3.5" 100 LOCKABLE DIVIDERS 9.99

DISK BOX 3.5" 100 LOCKABLE DIVIDERS 7.99

3.5" DISK HEAD CLEANER 3.99

GoldStar GoldStar

15 PACK GOLDSTAR 5.25" DSDD DISKS (80 TPI, F20K) 2.99

10 PACK GOLDSTAR 5.25" HIGH DENSITY DISKS (1.2 MEG) 3.99

PACK OF 30 3.5" GOLDSTAR HIGH DENSITY DISKS WITH LABELS 15.99

VERBATIM 3.5" DSDD DISK WITH LABEL 69p each or 22.99 FOR 50

3.5" GOLDSTAR HIGH DENSITY DISKS (1.4 MB) 89p each

3.5" DSDD VERBATIM DISK WITH LABEL 69p each

PACK OF 50 VERBATIM 3.5" DSDD DISKS WITH LABELS 22.99

PACK OF 10 TDK 3.5" MF-2DD DISKS (DSDD) 8.99

PACK OF 10 TDK 3.5" MF-2DD DISKS (HIGH DENSITY) 13.99

Inter-Media Ltd, Registered Office: 2 South Block, The Maltings, Newboldsworth, Harlow CM21 9PD. Incidentally, some games may not yet be released. Please phone sales on 0279 600204 for latest release dates and stock availability. To reserve the right to change prices and offers without prior notification. Please ring for latest information. E & O

WE ONLY SUPPLY MEMBERS BUT YOU CAN ORDER AS YOU JOIN. THERE IS A SURCHARGE OF 50p PER GAME ON TELEPHONED ORDERS. (PLEASE PRINT IN BLOCK CAPITALS)

WIN

Name _____

Address _____

Postcode _____

Phone _____ Machine _____

Enter membership number (if applicable) or Membership £6.99 UK, £8.99 EEC, £10.99 World

Item	
Item	
Item	
Item	

ALL PRICES INCLUDE UK POSTAGE & VAT £

Cheque/P.O./Access/Mastercard/Switch/Visa _____ Switch Issue No _____

--	--	--	--	--	--	--	--	--	--	--	--	--	--	--	--	--	--	--	--	--

Credit card expiry date _____ Signature _____

Cheques payable to: **SPECIAL RESERVE P.O. BOX 847, HARLOW, CM21 9PH**

Overseas Orders Surcharge (EC or World): Software orders please add £2.00 per item. Non-software items please add 25%. Hardware items supplied to UK mainland only. Overseas orders must be paid by credit card.

We only supply members but you can order as you join.

ANNUAL MEMBERSHIP: UK £6.99 EEC £8.99 WORLD £10.99

The Special Reserve full colour 48 page club magazine **NRG** is sent to all members bi-monthly. **NRG** features full reviews of new games plus mini-reviews, new products, Special Reserve charts, Release Schedule and hundreds of special offers.

PLUS - EVERY ISSUE CONTAINS £30 worth of money-off coupons to save even more money off our amazing prices

NRG also contains competitions to win £££s worth of prizes. Currently on offer is a chance to enter **THE BIG COMPETITION** in which First Prize consists of an **AMIGA, SUPER NES AND A MEGADRIVE, yes all three!** - There are 6 **SUPER NES's** and 6 **MEGADRIVES** up for grabs to the lucky runners up too! Closing date: Feb 28th 1993.

We sell games and accessories, all at amazing prices, for Megadrive, Master System, Game Gear, Super NES, Gameboy, NES, Lynx, Amiga, Atari ST, IBM PC and CDTV.

Best Service, Best Prices, Biggest Selection

120,000 people have joined Special Reserve, so don't delay, join today!







You can phone in your order or use this coupon ➡

Bewildered? Confused? Constrained?

Girl: Oh dear Daddy, how can I move all my IFF files from the root directory of my IDE HD to a floppy using the CLI?

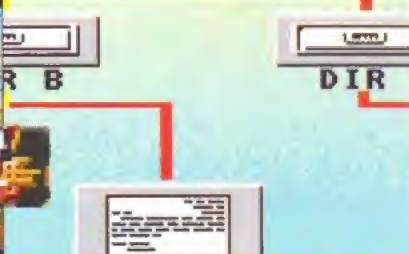
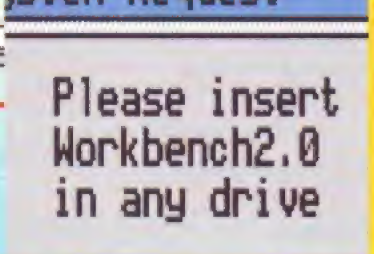
Dad: Ermm??!

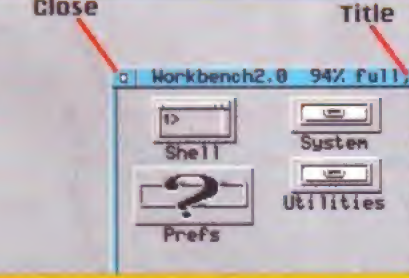

 <p>Would you like to do damage to people who keep on telling you amazing things about the Amiga?</p>	 <p>Do you know your beat-'em-ups from your shoot-'em-ups? Or for that matter from your god-games?</p>	 <p>Well, think that it's about time you did know your 'serious' software, your games and your hardware...</p>	 <p>...and within the pages of The Amiga Format Encyclopaedia we'll explain what Workbench is...</p>
 <p>...what exactly a RAM disk or for that matter any kind of disk (floppy or hard) call us over zealous but...</p>	 <p>...we'll even explain the entire Amiga range to you, who invented it and why it's called an Amiga...</p>	 <p>Oh and we'll also bung in lots of amusing stories about men called Jeff, chips called Denise...</p>	 <p>...and lots of information about software companies. It's going to be a blast, thank you for listening.</p>

The Amiga Format Illustrated Encyclopedia

You won't be for very much longer...

AMIGA **FORMAT SPECIAL**

**Nobody knows everything,
but you could get close, if
you read...**

The Illustrated Encyclopaedia of the Amiga

(and it's all for under four notes!)

of the Amiga is priced at £3.95

How it Works: the Amiga

Do you have any idea of what's going on inside every time you switch on your Amiga? Perhaps you should, because the more you understand it, the better equipped you are to decide how to expand and how to use your machine. **Damien Noonan** takes the Amiga apart and reveals the secrets of its inner workings...

AMIGA FORMAT

32

FEBRUARY 1993

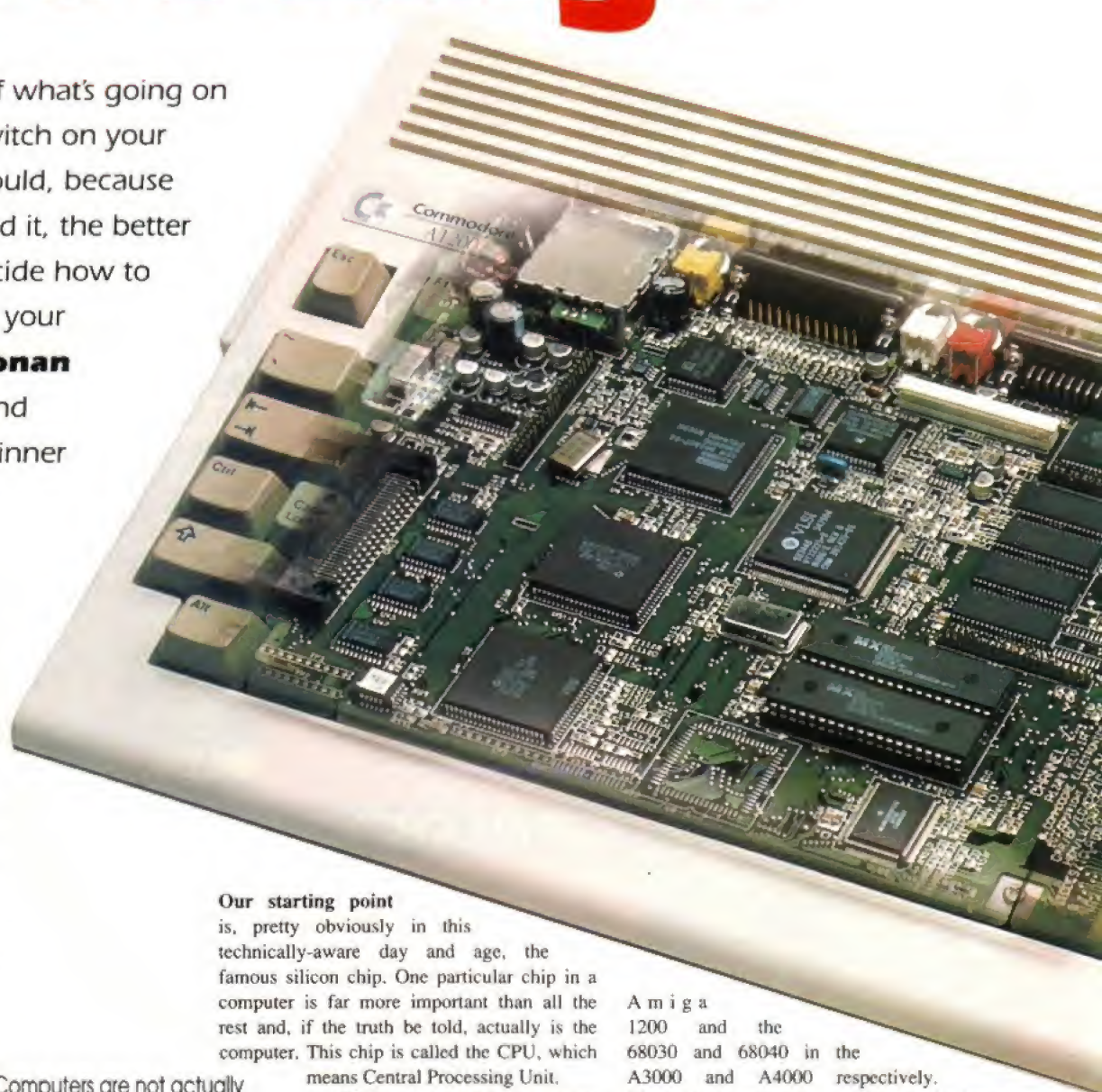

SO DO YOU understand your Amiga? Perhaps you should. It's easy to be confused by all the numbers and abbreviations that fly around when we're talking about the specification of an Amiga, but if you understand how your Amiga works, it all becomes clear.

Take the A1200 as an example. It features full 32-bit architecture, 2Mb of RAM, 68020 CPU running at a clock speed of 14MHz, 880K DS/DD internal disk drive, and a 96-key QWERTY keyboard.

It's a multi-tasking computer and includes the Commodore AA (or AGA) custom chip set for a palette of 16,777,216 colours, of which anything from 2 to 256 or even 262,000 can be displayed on the screen at once. It comes with Kickstart and Workbench version 3 and it has four-channel stereo sound.

Make sense of any or all of that lot? Well, even if you did, it's still worth reading on. Because we're going to explain how a computer works, and then we'll move on to show why the Amiga is different from – and superior to – most other computers. We're going to dive right down to the deepest levels of complexity, strip it down to nuts and bolts, here, so hang on to your hat!

• Computers are not actually very clever at all. What makes them a marvel of modern technology is that a chip includes hundreds and thousands of extremely small electrical components •

Our starting point

is, pretty obviously in this technically-aware day and age, the famous silicon chip. One particular chip in a computer is far more important than all the rest and, if the truth be told, actually is the computer. This chip is called the CPU, which means Central Processing Unit.

CPUs are created by microchip companies and then bought by computer manufacturers, who design their computers around the CPU chips. The CPU in an Amiga is made by a firm called Motorola, and in actual fact the very same chip is used by both the Atari ST and Apple Macintosh computers.

The Motorola 68000 (say 'sixty-eight thousand') CPU chip used in the A500 and A600 models of Amiga is the little brother in a 'family' of chips. Its big brothers are faster – they can process the same amount of data in less time, or a larger amount of data in the same time.

The family includes the 68020 (say 'six-eight-oh-two-oh') which is the CPU in the

Amiga 1200 and the 68030 and 68040 in the A3000 and A4000 respectively. Motorola are currently working on the latest chip in the 68000 series, the 68060.

The higher-up chips, like the 68020 in the A1200, are faster than the plain old 68000 for two reasons. One: they are 32-bit CPUs rather than 16-bit CPUs. Two: they have a faster 'clock speed' which means that everything they do, they do faster.

Exactly how both these things affect the speed of the CPU will be explained very soon. First, let's look at what a silicon chip is and how it works.

The first thing to grasp about computers is they are not actually very clever at all. They do the very simplest of calculations using the very simplest electrical components. What makes them a marvel of modern technology is

How a silicon chip is made

Silicon is sand, the second most common chemical element on Earth, after oxygen. The reason it's used for chips is that it's what's known as a 'semi-conductor'. When it's pure, it won't conduct electricity, but when it's mixed with other substances, it can.

What's more, depending what kind of chemical you put in it, silicon becomes either positively charged or negatively charged. The addition of phosphorous creates 'n-type' negatively-charged silicon while boron creates 'p-type' positively-charged stuff. And, as you may know from studying electronics, it's the difference between positive and negative charges that makes the electrical world go round.

So, how to make a chip. First take 99.9 percent pure silicon, then heat it to 1,410 degrees centigrade to melt it and 'grow' a crystal of silicon.

Cool it and slice it into wafers. That's the base for your chip and it's about half a millimetre thick.

Next cover it with a layer of silicon oxide, by heating it and passing oxygen gas over. Silicon oxide is, as it happens, a lousy conductor. The chip-making process relies on building up layers of bits that can and can't conduct.

Next step is to etch holes in the layer of silicon oxide, which is done using a photo-etching process. Certain areas of the silicon are made bare again, and these are then treated with the necessary chemicals to make them p-type or n-type. The process is repeated, building up layers of insulating silicon oxide, positively charged silicon and negatively charged silicon to create transistors.

The diagram to the right shows how this is done to make a transistor on a chip. It looks complicated, but don't worry about the detail: it's just meant to show how layers of positive, negative and insulator go to make up a tiny electrical circuit, one of many thousands of transistors on each silicon chip.

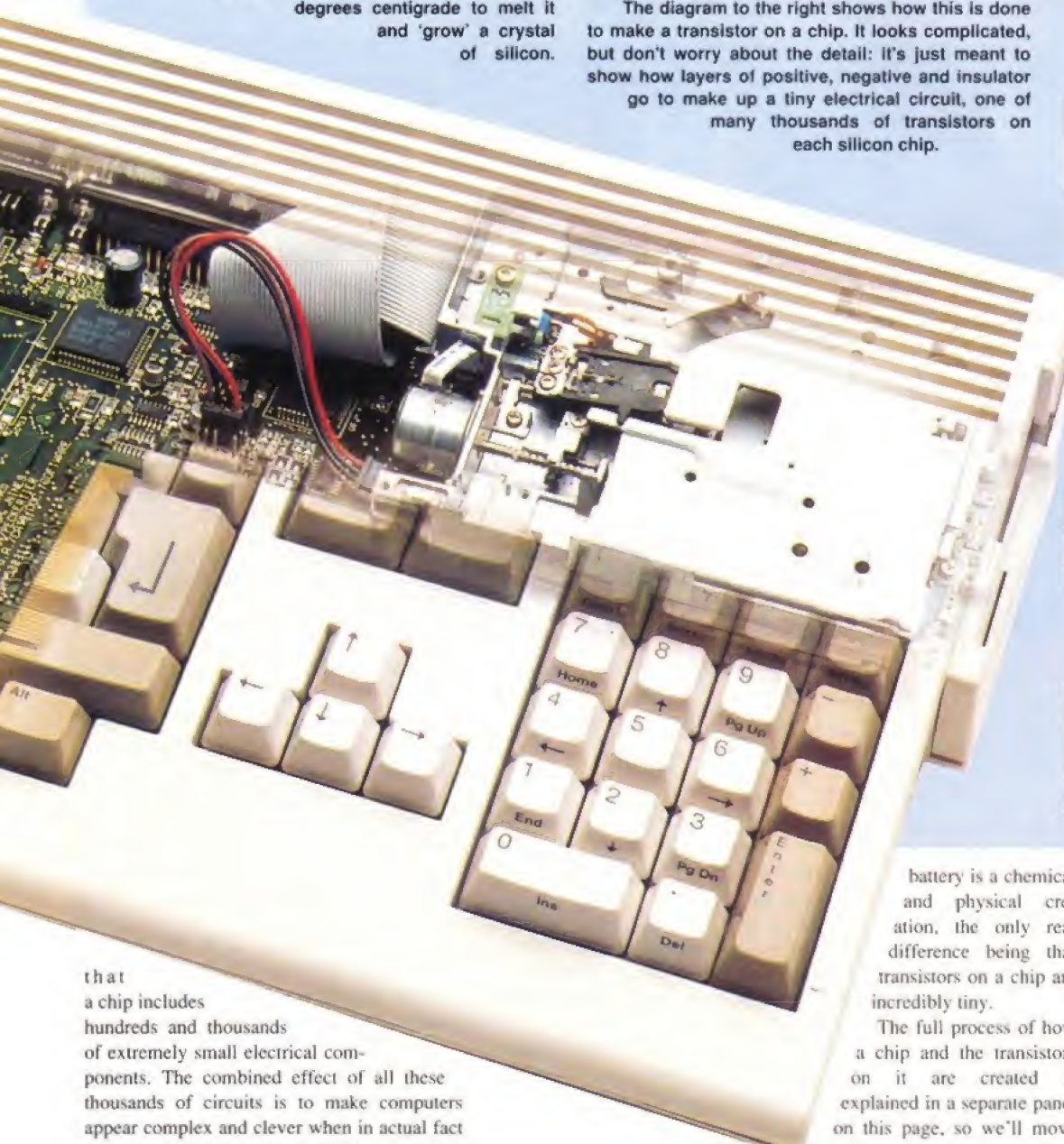
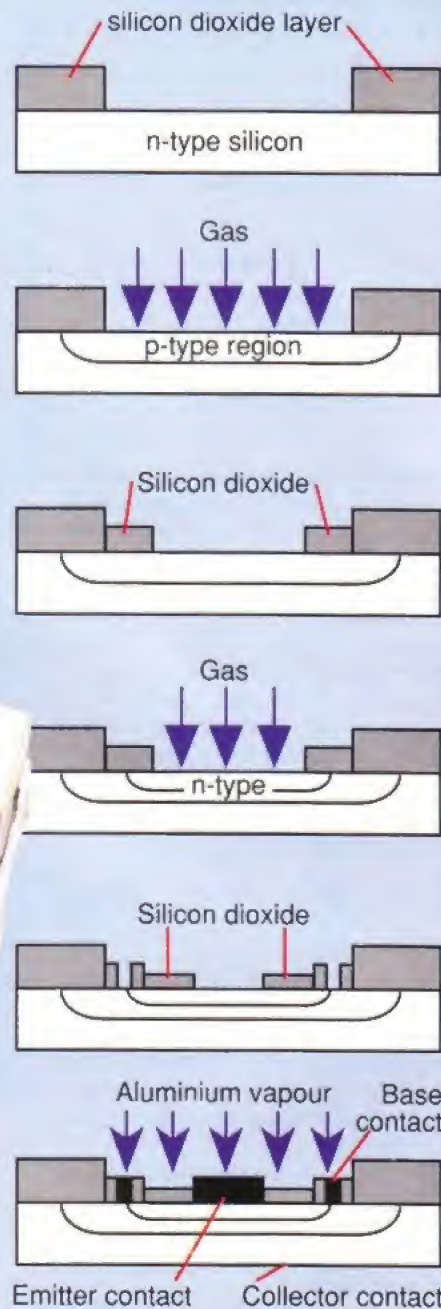

that a chip includes hundreds and thousands of extremely small electrical components. The combined effect of all these thousands of circuits is to make computers appear complex and clever when in actual fact they are just throwing sheer weight of numbers at the problem.

The electrical components on a chip are mostly resistors, diodes and transistors, the transistors being far and away the most important. The many thousands of transistors on a chip are very much chemical and physical creations, in much the same way that an electrical

battery is a chemical and physical creation, the only real difference being that transistors on a chip are incredibly tiny.

The full process of how a chip and the transistors on it are created is explained in a separate panel on this page, so we'll move swiftly along to how they

work in a computer.

A transistor is, in effect, simply a switch. It's either on or off: when it's on, an electrical current is flowing from one side to the other. It's switched on and off by applying a voltage to a 'control wire'.

And this is where binary comes in.

Computers, as I'm sure you know, work in the mathematical 'base 2' or binary, in which all numbers are represented by a one (1) or a zero (0). If current is flowing in a transistor – if the switch is 'on' – that is the equivalent of a 1. If the current is not flowing – if the switch is off – that is the equivalent of a 0. In this way, binary numbers (1 and 0) are represented by a physical state (electricity flowing or not flowing). That's why a computer is a machine. Clear so far? Right, let's see how simple electrical circuits can make calculations...

All the calculations a computer does are based around a concept called 'logic gates'. We'll see in a moment how different combinations of logic gates can be used to do complex calculations, but first here's how a logic gate

Continued overleaf

works. We'll demonstrate it by using two extremely simple electrical circuits that involve a battery and a bulb. Remember that transistors are just switches, so in our simple circuits we'll use switches instead.

The first kind is known as an AND gate. It looks like this.

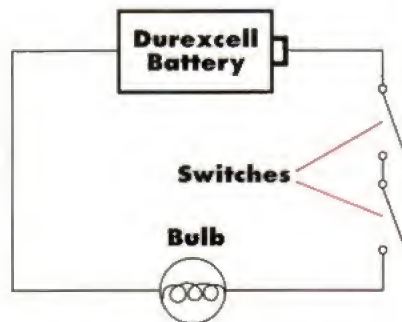

It's called an AND gate because both the first switch AND the second switch have to be in the 'on' position for the bulb to light. If both are off, nothing will happen. If the first is on and the second is off, nothing will happen. If the first is off and the second is on, still nothing happens.

Right, now try and think of the positions of the switches as being two 'inputs' and the bulb as the 'output'. Remember that a current flowing (a switch being on) is expressed as a one, and a switch being off is represented by a zero, and you can represent our AND gate circuit as follows:

Input 1	AND	Input 2	Output
0	AND	0	0
1	AND	0	0
0	AND	1	0
1	AND	1	1

So the result of passing two inputs into an AND gate is that only if input 1 AND input 2 are both 1 will the output be 1. OK, that's the AND gate sussed.

Our other basic type of logic gate is the OR gate. In this simple electrical circuit, the two switches are connected 'in parallel' (as opposed to 'in serial' in the first example). The circuit looks like this...

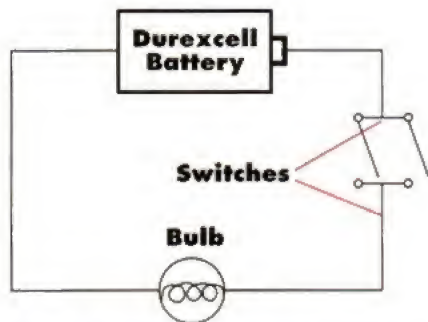

As you can see, with this second electrical circuit only one of the switches has to be on for the bulb to light up.

If switch one OR switch two is on, you get a light. That's why it's called an OR gate. Again, if we switch over to expressing this in binary maths and put it in a little results table, it looks like this...

How logic gates make maths

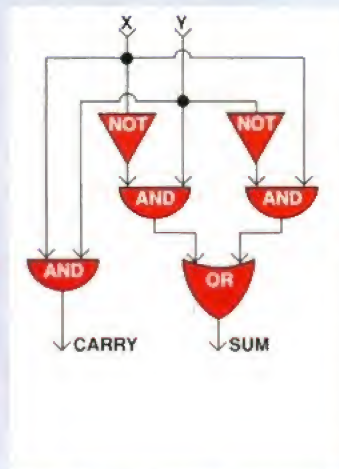

The HALF ADDER is so called because it can't handle 'carrying' a leftover digit.

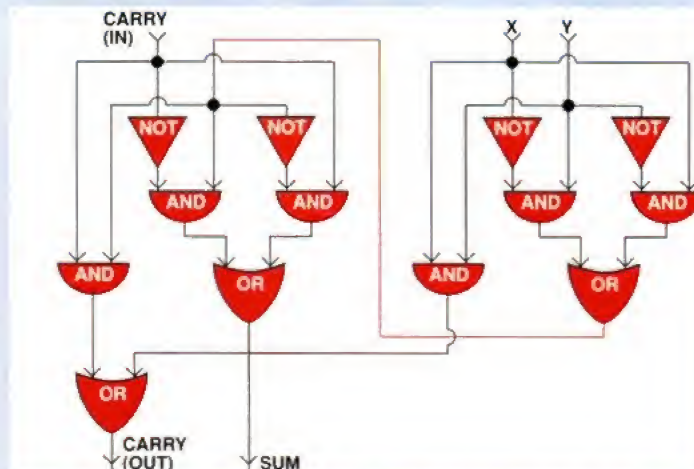

The FULL ADDER is a combination of two or more half adders and an OR gate and can happily handle a sum that involves carrying a leftover digit.

The concept of AND, OR and NOT gates (see the main flow of the article if you haven't read about these already) might seem a bit useless. But by combining just these three different types of gate (and there are other types) you can create a 'logic circuit' that does the vital job of adding binary numbers.

The diagrams here will give you an idea of how numbers are added using ANDs, ORs and NOTs. Try to remember what each type of gate does and try to follow it.

The best way to see how it works is by trying different values (only 1 and 0 are allowed, remember!) for the inputs and trace through the outputs to see what happens through the process - scribbling 1s and 0s in pencil on the diagrams is easiest.

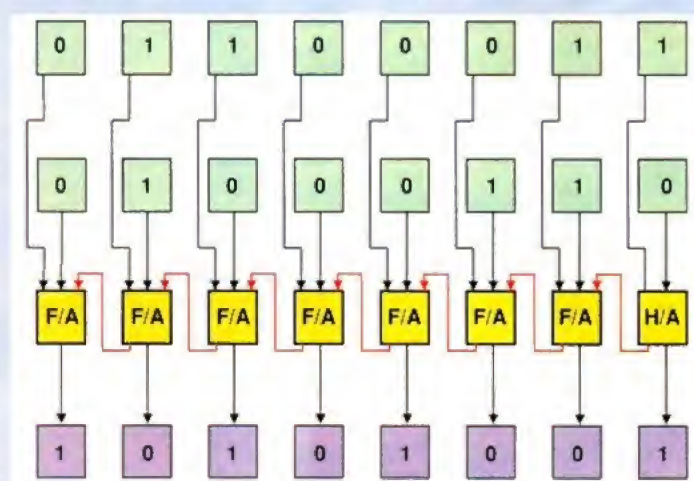

And this is how you combine the two to create a complete logic circuit for adding an eight-digit binary number. Don't worry if you don't understand this (I don't!) so long as you can follow how the two above get the right results.

Input 1	OR	Input 2	Output
0	OR	0	0
1	OR	0	1
0	OR	1	1
1	OR	1	1

So that's how switches (or rather transistors) are used to make up logic gates. Logic gates might seem a bit weird, but they are the basis of all computer calculations.

Our next job is to discover how a set of logic gates can be combined to make a proper calculation. But first, there's a third type of gate we need to know about. This is called a NOT gate.

A NOT gate is actually simpler than an AND or an OR because it only needs one input. What it does is simply switch that input to the opposite, so with an input of 1 you get an output of 0 and with an input of 0 you get an output of 1. It's scarily reminiscent of Wayne's World language and it could be shown like this:

Input	NOT	Output
0	NOT	1
1	NOT	0

OK, at this point we're going to cheat slightly because we'll need a pretty complicated diagram to show you how these three gates are combined to make a simple calculation like addition. Skip now to the panel called 'How logic gates are used to do addition', then come back here very much the wiser.

OK? Did you get that? If you try inputting 1s and 0s into the half adder and full adder systems, you should be able to see how they come up with the right answer.

That's addition sorted out. So how do you do the other mathematical functions using logic gates? Well, we haven't got the space to go into it in great detail, but here's a brief idea.

Multiplication in binary is pretty easy, because at any stage you're only ever multiplying by zero, in which case the output is zero, or one, in which case the output is exactly the same as the input. All you have to do, then, is shift the numbers about appropriately and add them together using the same adder gate sets. Subtraction is also pretty simple, because all you have to do is add a negative number. This means that, again, you can use the addition logic gates.

Continued on Page 36

EVERYONE KNOWS BUT INDY. AND HE'D BETTER LEARN FAST.

Plato knew about Atlantis.

In a lost dialogue he wrote about the famed city and orichalcum, the mysterious element that powered the Atlantean's amazing machinery.

The Nazis know about Atlantis.

They tracked down the lost dialogue, and realised orichalcum would yield them the ultimate weapon of the age.

Sophia knows about Atlantis.

She unearthed a mysterious necklace and beads of orichalcum during an Icelandic archeological dig with Indy. Their magical properties made her a psychic.

Everyone knows but Indy.

And he's got to learn fast. The Nazis are one step ahead of him - from Iceland to North Africa from the Azores to... Atlantis.

Available on:
IBM PC, VGA,
Coming soon on Amiga



Our biggest, most complex adventure ever. Huge, More than 200 rooms furnished with vivid VGA art. Roto-scoped animation, a new icon interface. Exciting LucasArts electronic storytelling technology. Dramatic theatrical lighting.

Three ways to play and replay.

Three roads lead to Atlantis. "Puzzle path" features tough but logical riddles. "Action path" demands two-fisted reflexes. "Team path" calls on your intuitive sense and interpersonal skills.

Cinematic soundtrack.

iMUSE™, our brand new interactive sound system, supports all major sound cards with situation-based sound effects and music.

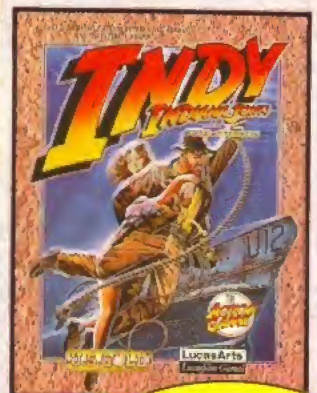

COMING SOON FOR
PC, Atari ST, Amiga,
Spectrum, Amstrad & C64

INDIANA JONES[®] and the FATE of ATLANTIS™



Iceland. The start of a new chapter in the history of Atlantis.



Indy and Sophia cross many paths on the way to rediscovering the lost continent.

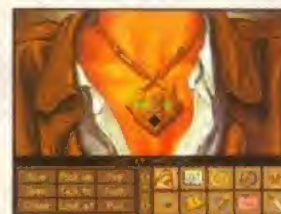

The ancient necklace hides many mysteries from the past.

Screen shots are only intended to be illustrative of the gameplay and not the screen graphics which may vary considerably between different formats in quality and appearance and are subject to the computers specifications.

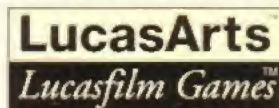

Indiana Jones and the Fate of Atlantis™ and ©1992 LucasArts Entertainment Company. INDIANA JONES™ is a Registered trademark of Lucasfilm Ltd. Used under authorization. All rights reserved.

HINTS TIPS N HELP CALL THE
PHONE

SPELLJAMMER • PROPHECY OF THE SHADOW • THE SUMMONING • DARK SUN • EYE OF THE BEHOLDER • LEGEND OF DARKMOON (EYE OF THE BEHOLDER II) • DRAGONS OF FLAME • HEROES OF THE LANCE TEL: 0839 654 139
OPERATION STEALTH • ANOTHER WORLD • FLASHBACK • CRUISE FOR A CORPSE TEL: 0839 654 284 LUCASFILM
HELPLINE • LECHUCK'S REVENGE (MONKEY ISLAND 2) • INDIANA JONES (LAST CRUSADE & FATE OF ATLANTIS) • ZAK
MCKRACKEN • MANIAC MANSION • LOOM • SECRET OF MONKEY ISLAND • BATTLE OF BRITAIN TEL: 0839 654 123
INFORMATION LINE: 0839 654 124 • LEGENDS OF VALOUR TEL: 0839 993 366 • ACCESS HELPLINE:
AMAZON TEL: 0839 654 394 • SIR TECH HELPLINE: CRUSADERS OF THE DARK SAVANT TEL: 0839 994 477
If you are under 18 please get permission to use the telephone. Calls cost 36p per minute cheap rate, 48p per minute all other times.

Service provided by U.S. GOLD LTD., UNITS 2/3, HOLFORD WAY, HOLFORD, BIRMINGHAM B6 7AL.

Division is the only one that presents special problems. Essentially, the simplest way of explaining how it's done is that the number you're dividing by is added to itself and a count kept of how many times you added it, checking all the time to see if the number you've reached is greater than or equal to the one you're dividing by. It's complex, but again it uses the adder circuits.

All the logic circuits for these operations are kept in an area of the CPU called the ALU (Arithmetic Logic Unit). Let's take a look at what else makes up the CPU.

Well, as we've just said, there's the ALU which does all the calculations. As well as that, there are a number of areas of storage known as registers. These use transistors to store binary data, 1s and 0s, in exactly the same way as RAM does, which we'll look at in a minute.

Also in the CPU is something called the program counter, which stores the next instruction ready to be executed by the ALU. Then there's the control block, which is 'hard wired' (set up permanently in the manufacturing process) to interpret the instructions that are passed into the CPU.

Last, and by no means least, we have the CPU's connections with the outside world. These are the address pins, the data pins and the control pins. We'll see how these work in a moment: first, let's explain how RAM works.

If the CPU is the computer itself, and therefore the most important part of the Amiga, RAM (Random Access Memory) is the second most important part. It's here that all the data and instructions, in binary, which the CPU will process are loaded and stored.

The full name, Random Access Memory, doesn't mean an awful lot on its own, but there's one important thing to remember about RAM and that is that it's not permanent. It will only hold data as long as it is being supplied with power. So when you switch off your Amiga, all the data stored in RAM disappears.

RAM chips are just silicon chips packed full of transistors. Each transistor is switched on to indicate a binary 1, or switched off to indicate a binary 0. In this way a RAM chip can store binary data.

The RAM chips, like the CPU, have lots of pins on the outside to connect them to the outside world. Once again, these pins are made up of address pins and data pins, as well as a power supply and an earth.

The address pins are how the CPU finds the particular chunks of data that it needs. Each single transistor on the chip has its own unique number, and that number is called its address. So when the CPU needs some data from a RAM chip, it sends out an address signal to RAM telling it which address it wants the data from.

This signal passes along a set of wires called the address bus - I've no idea why it's a 'bus', unless it's because data travels along it - and reaches the RAM's address pins. The data from RAM is then sent back from the data pins on the RAM chip, via the data bus (another set of wires) to the data pins on the CPU.

All clear so far? Now, this is where we learn why the A600 is a 16-bit computer and the A1200 is a 32-bit computer. It's because the Motorola 68000 CPU in the A600 has 16 data pins and can therefore load 16 bits of information - 16 binary 1s or 0s - at one time. The 68020 CPU in the A1200 has 32 data pins

Continued on Page 39

Disk

The basic idea of disk storage is almost exactly the same as audio or video cassettes - information is recorded magnetically onto a thin coating of magnetically sensitive metal oxide. The difference is that in a disk the magnetic coating sits on top of a disc of plastic - obviously! - rather than a ribbon of tape.

Like a tape player, a disk drive has a 'head' to record and play back (write and read) data. The disk drive uses the same head for read and write, and has two heads, one above and one below the disk. This means it can read and write data to both top and bottom of the floppy, so it's what's called a 'double-sided' disk drive. Floppy disks often say 'DS/DD' on them, which stands for 'double-sided, double density'.

A 3.5" (three-and-a-half-inch, the diameter of the disk) floppy needs to be formatted (prepared) for use as an Amiga disk before you can store anything on it. Amiga-formatted disks can store a maximum 880 Kilobytes of data (if you're not sure about what a Kilobyte is, have a look at the separate box on the left: 'What those mysterious numbers and letters mean').

Some disks are labelled 'HD' which stands for 'high-density' - these are also distinguished by an extra hole on the corner opposite the write-protect tab. High-density disks can store twice as much data when they're used in a special disk drive - so far, only the Amiga 4000 has a high-density floppy-disk drive fitted.

The data on a disk is organised in concentric rings and not, as you might expect, in a spiral like an LP record. Each ring is called a track, and the Amiga fits 80 tracks on a disk (numbered 0 to 79 - you can see them counting down when you're formatting a disk).

Within the tracks, data is organised in blocks, a block being 488 bytes. Particularly important are the first two blocks of Track 0 - one on the top of the disk, one on the lower - which together make up the 'bootblock'. Data stored here tells the CPU whether this disk is self-booting and if that's the case, starts it running a program.

Also important is the 'directory block' (again, it's actually more than one block) which lives on Track 40. This stores a record of where on the disk files are kept, so the disk drive always looks here first when it's trying to find a file.

Incidentally, this is why it's possible to 'undelete' files you've accidentally

What those mysterious numbers and letters mean

512K? 20Mb? Two Megabytes? Bits, bytes, Kilobytes? What is it all about, eh? Well, it's actually all quite simple. Every number associated with computers is based on binary (base 2) and it works like this.

A single binary 1 or 0 is called a 'bit', which is short for 'binary digit'. Eight bits make what's called, for no apparent reason, a 'byte'.

This kind of quantity of data is pretty appropriate to the CPU, which is working on 16 bits or 32 bits at a time. But when you're considering the amount of data stored on a disk, or that makes up a program, you need much bigger numbers.

Step up, the Kilobyte. As you might expect, the Kilo on the start has to do with thousands, as in 'Kilogram' = 1,000 grams or 'Kilometre' = 1,000 metres. Only being to do with binary, it doesn't actually mean 1,000 bytes: it means 1,024 (which is two to the power of ten). The usual abbreviation for a Kilobyte, 1024 bytes, is K: so a disk's capacity of 880K is $880 \times 1024 \times 8 = 7,208,960$ bits.

Next step up is the Megabyte, which as you might expect is based on a million bytes, but once again is binary - so a Megabyte is actually 1,024K. The original A500 had 512K of RAM, whereas the A600 has twice as much - a Megabyte. The Megabyte is abbreviated to Mb, as in 1Mb of RAM, and is also colloquially called 'a

Meg'. One last thing worth noting is that occasionally, particularly when talking about chips, you'll see Kilobits (Kbits) and Megabits (Mbits) referred to. Because there are 8 bits to a byte, to find out what a Kbit or Mbit number means in real money, all you have to do is divide by eight - so an impressive-sounding 8 Mbit Sega game cartridge is actually only a normal 1Mb.

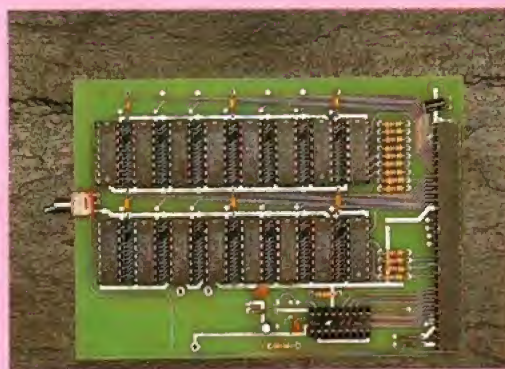

So what does it mean if you have 512K or 1Mb of RAM? The secret is how many 1s or 0s these chips will store.

drives explained



Even though a hard drive can store much more data – a typical drive might be about 40Mb storage capacity as opposed to less than 1Mb on a floppy – it's essentially very similar. The main difference is that, as the name implies, the disc itself on which the magnetic medium is laid is hard – it's made of metal and referred to as a 'platen'.

Because the disc is hard, and because the mechanism is sealed in a vacuum, the whole thing can be much, much more accurate: which means that each track is much smaller, many more tracks can be crammed into the same space and as a result much, much more data can be stored. Because they spin much faster, hard drives also load and save data much more quickly than floppies do.

Hard drive units come in two main types, defined by how they connect to the Amiga. IDE drives plug in with a simple cable to the connector inside an A600 or A1200: these drives come in two sizes (3.5" and 2.5") and were originally designed for portable computers, so they're small and have a low power consumption.

The other type of drive attaches via a SCSI (Small Computer Systems Interface) connector to either the edge connector of an A500 or the card slot of a larger Amiga. This type of drive tends to use a kind of hard drive unit known as a Quantum, which is then attached to a SCSI interface and the appropriate Amiga casing and connectors by an Amiga peripheral manufacturer like GVP.

These drives are more expensive because you pay for all the extras over and above the basic hard drive unit, but SCSI drives tend to be quicker at loading and saving data than IDE ones.



If you've never taken a floppy disk apart, you should do. It's worth the few pence a disk costs to understand what's inside the things.

The metal shutter is pushed back when you put the disk into the drive – it covers the hole into which the disk drive head protrudes to read and write data. Bend the shutter and remove it, and the little spring that keeps it closed will ping off across the room. Now you can split the two halves of the case apart.

Inside, there's not a great deal there – the floppy disk itself, a couple of 'cushions' of soft paper to make things smooth when the disk is spinning and the write-protect tab, which is just a bit of plastic.

Now you understand why these disks are called floppy. Although they have a hard plastic case, the circle of Mylar plastic is itself quite bendy. It's attached to a metal 'hub', which has holes in: pins in the disk drive stick into these holes to spin the disk.

deleted: the Amiga wipes the record of the file from the directory block, but doesn't actually wipe away the data itself.

A clever program (and these are available in the PD as well as commercially, so they're not expensive) can look through the whole disk to see if the actual data is still there, even though there's no record of it in the directory. An example is the extra CLI command Undelete, which is available on many PD collections.

One last point about disk drives, and especially about hard drives: their storage capacity is no longer generally referred to as 'memory' even though they do remember data. If people talk about the memory in your machine, it's usually RAM they mean. So an A600HD with 1Mb of RAM and a 20Mb hard disk drive has 'a Meg of memory and 20 Megs of hard disk space,' in common parlance. Not 20 Megabytes of memory.

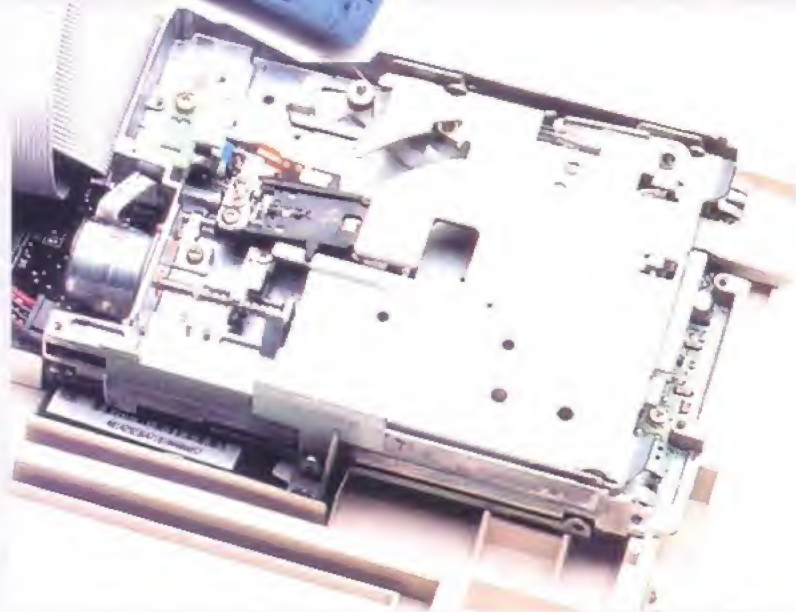

The disk drive mechanism is quite simple. There's a pin on a spring that checks to see that the write-protect tab is off if you want to write data to the disk; there's a motor to spin the disk; and there's the two read/write heads, one above the disk and one below.

Unlike a hard drive, a floppy disk only spins when it's actually reading or writing data. That's why you should always make sure the drive light is out before flipping a disk – if you take the disk out while it's spinning, both the disk and the drive may be damaged.

Your Specialist



ADI

stores: North West:

Bolton Computer Centre	Bolton	0204 841937
Castle Computers	Lancaster	0524 61133
Computer Shop	Preston	0772 201482
Computer World	Blackpool	0253 21657
Computer World UK	Bolton	0204 495011
Games Store	Blackpool	0253 291383
Games Store	Carlisle	0228 28161
Long Eaton Software	Long Eaton, Notts	0602 728555
VU Data	Ashton Under Lyne	061 339 0326
VU Data	Stockport	061 477 6739

Midland and Wales:

Comptazia	Merryhill, Birmingham	0922 614346
Games World	Bristol	0272 251533
Mr Disk	Queensway	021 6161168
North Notts Computers	Sutton in Ashfield	0623 556686
Soft Spot	Banbury	0295 268921
Soft Centre	Cwmbran	0633 868131

South East:

A & C	Farnborough	0252 375088
ACM	Alton	0420 541167
Barkmans	Kingston Upon Thames	081 546 5941
Computer World	Canterbury	0227 766788
Database	Thurrock	0708 890976
Erol Computers	Walthamstow	081 520 7763
Faxminster	Hatfield	0707 272919
Future World	Basildon	0268 270013
Gamer	Brighton	0273 728681
GB Microland	Waterlooville	0705 269333
Input	The Plaza, W1	071 6362666
Invicta	Tunbridge Wells	0892 511542
Logic	Cheshunt	0992 25323
Sore Thumbs	Billericay	0277 633003

North East:

Chips	Middlesborough	0642 252509
Chips	Stockton	0642 618256
Computer Stores	Wakefield	0924 290159
Computer Stores	Huddersfield	0484 514405
Computer Stores	Doncaster	0302 325260
Computer Stores	Leeds	0532 429284
Computer Stores	Sheffield	0742 780083
Tomorrow's World	Hull	0482 24887
Topsoft	Stockton	0642 670503

EUROPRESS
SOFTWARE

Europa House, Adlington Park,
Macclesfield SK10 4NP
Telephone: 0625 859333

Laugh while you learn ...with



ADI

Explore English, Maths and French with ADI, the lovable extra-terrestrial. As you learn, he'll entertain you with funny remarks, whistly voice and weird faces. He'll congratulate you when you do well and cajole you if you make mistakes.

There's one package for each school year and the software closely follows the guidelines of the National Curriculum, drawing on the talents of some of the most gifted teachers in the country. As a result ADI ideally complements what students are learning in school, and acts as a superb revision tool.



Available NOW:

English 11/12 12/13 13/14 14/5

Having problems with your nouns and adjectives? Can't sort out your suffixes and prefixes? You need ADI English, covering all the basic elements of English grammar required by the National Curriculum syllabus.

Maths 11/12 12/13 13/14 14/5

If your algebra and geometry are causing you grief, look no further than ADI Maths. These are just two of the topics covered by the packages - whatever your maths problem, ADI's got the answer.

French 11/12 12/13 13/14 14/5

Say bonjour to French with ADI! The ADI French 11/12 package introduces first year students and beginners to France and French, and older students will find the 14/15 package ideal as a revision aid.

...and each pack costs just £25.99!

Join the ADI family today!

EUROPRESS
SOFTWARE

Europa House, Adlington Park,
Macclesfield SK10 4NP
Telephone: 0625 859333

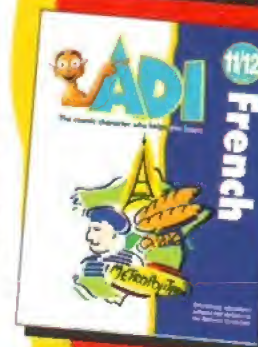
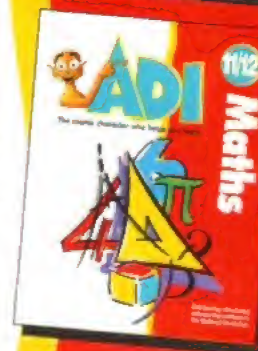
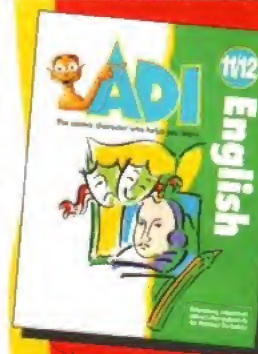

Available for
the Amiga, PC
and ST.

On sale at all good software
retailers including Boots,
Virgin and WH Smith.

and can therefore load 32 bits of data at one go, which makes it substantially quicker. Older computers, like the Commodore 64, had 8-bit CPUs which made them substantially slower.

There's one other thing that controls how fast a CPU is, and that's called its clock speed. The 68000 in the A600 is 'clocked' at 7.14 MHz (MegaHertz, which means 'millions of cycles per second'). This simply means that the clock 'ticks' (or actually, puts out an electronic pulse) 7.14 million times every second.

Everything that the computer does is controlled by the speed of this ticking clock. It keeps things organised. Only one instruction is allowed to be carried out each time the clock ticks. That instruction might be sending an address to RAM, receiving data from RAM, or performing a mathematical operation. Whatever the instruction is, the CPU can only do one each time the clock ticks. It's from these simple building blocks - moving data about and simple mathematical calculations - that even the most complicated program is made up.

If an Amiga has a CPU with a faster clock speed, it can process more instructions in the same amount of time. So the A1200, with its 68020 CPU clocked at 14MHz, is twice as fast at processing data. Remember, though, that the 68020 CPU can also load twice as much data at a time (32 bits rather than just 16) so this makes it faster yet.

Because all the CPUs in the Motorola 68000 series are compatible, you can fit a faster processor to your Amiga to make it run faster. This is what's known as

an accelerator card. The GVP A530 hard drive for the A500, for example, includes an accelerator card featuring a 68030 processor clocked at 40MHz, which makes it much, much faster than a normal 68000.

There's one other important term to introduce here, and that's the word architecture. This word is used loosely to describe the way in which the designers of a computer have arranged all the elements that make up the computer and the way they are all joined together.

The important difference between the A500 or A600 and the A1200 is that the 1200 has a full 32-bit architecture. This means the connection from the RAM chips to the CPU - the data bus - is 32-bit, whereas on the A500, A600, A1500 and Amiga 2000 it is only 16-bit. The effect this has is that if you fit a 32-bit CPU to one of these Amigas, it still only has 16-bit data access and is therefore not as quick as potentially it could be.

Accelerator cards for the older machines can still run very, very quickly, so it's not something you ought to worry about. We mention it mainly to explain why we refer to the A1200 (and, indeed, A4000) as a 'true 32-bit' machine.

One last point. The other nice thing about the CPUs from the 68020 upwards is that they don't have to work on their own. They can run in tandem with another chip called a 'maths co-processor' or 'Floating Point Unit', or FPU for short. There are two different FPU chips available, with the numbers 68881 and 68882, the latter being the more powerful.

The FPU does just one type of calculation work, but does it very well indeed. It deals with something

called 'floating point' calculations. For reasons to do with the way binary maths works, which would be far too complex to explain here even if I understood it myself, programmers use all kinds of different ways of expressing numbers, floating point being one of them. The name means that the position of the decimal point doesn't remain the same, it floats about.

Anyway, that's really too much to go into here. The point is that certain kinds of programming, particularly 3D and ray-tracing, rely heavily on floating point calculations and that an FPU means the Amiga can handle them much more quickly, because it takes some pressure off the CPU. The A1200 has a space on the circuit board for an FPU to be soldered on, though it doesn't currently come with one. Most accelerator cards have an FPU as an optional extra.

Time for a quick recap. By this stage, you should have a pretty decent idea of how the two basic elements of the Amiga - RAM and the CPU - work. By sending out address signals to RAM via the address bus, the CPU gets it to send the exact data it needs to it down the data bus. It stores this data in a register in the CPU, and it can then get the ALU to perform a calculation on it - say, add it to the contents of a second register. The result would be stored in another register.

So how do you program anything worthwhile? Well, let's take a look at how that works.

The CPU is dealing in pure binary. When it's built, certain sets of binary digits - certain numbers, in other words - are set aside as instructions. If the CPU pulls

Continued overleaf

Interface ports - talking to the world

The Amiga has all manner of plugs and sockets, not only on the back but also inside the machine. An interface is simply a device that translates Amiga inputs and outputs into a language that can be used by other computers or by different kinds of computer hardware. Here's a quick run-down of what the Amiga's interfaces do...

PARALLEL PORT

Another standard kind of interface, this time something known as a Centronics. Ideal for modems, but also used by sound samplers, video digitisers and scanners because it's a fast way of shifting data into the Amiga.

RF OUTPUT

Standing for 'radio frequency', RF is the kind of TV signal that your TV's aerial socket expects to get. Lower quality than RGB is evident in distorted colours and less precise images.

PCMCIA 'CREDIT CARD' SLOT

A new standard that arrived with the A600, this is for hardware expansions on compact cards, RAM expansions being the most popular type. It's a standard developed by the world of business computing and should give the Amiga a range of cheap, easy-to-fit peripherals over the next couple of years, though it's still in its infancy right now.

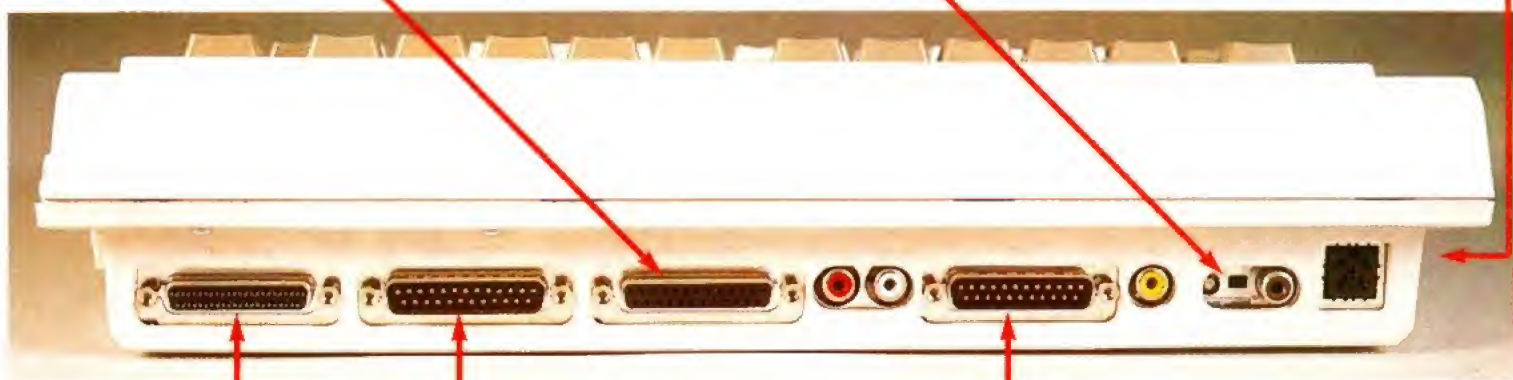

DISK DRIVE PORT

Plug your second disk drive in here. Includes a power supply for the disk drive, too.

SERIAL PORT

This is a standard type of interface used by many kinds of computer and by lots of other kinds of hardware: it's an RS232 port. It's used mainly for connecting printers.

RGB VIDEO

Outputs an RGB (Read, Green, Blue) signal for use by a monitor or a telly that has a SCART (also called Peritel or Euroconnector) socket. RGB is the purest kind of TV signal: a 'composite' or 'RF' signal mixes colour information up and then decodes it later.



these numbers out of RAM, it recognises them as instructions and executes them.

The 68000 CPU is, therefore, set up at manufacture with a particular set of instructions that it can perform and, pretty obviously, this is known as the CPU's 'instruction set'. Simple enough.

The programmer could, if he wanted, program entirely in binary. This, strictly speaking, is what's known as 'machine code' because it uses the binary codes of the CPU. Since even the simplest program would take pages of 1s and 0s, however, it would be absolutely impossible to tell what the heck you were doing, or to read the code.

To make it easier, a 'low-level' programming language replaces the binary instructions with simple words like 'add' and 'move'. This is known as Assembly Language or just Assembler. A low-level language is as close to the CPU's instruction set as a programmer gets, and is therefore the most complicated type of programming language to learn. Other 'higher-level' programming languages, like Basic and C, replace sets of Assembler codes with simple phrases in the English language, so they're easier to learn.

The programmer writes his program in a program editor, which in effect is just a word processor. The finished program is then run through another program called a compiler, which translates the program into the instruction codes used by the CPU.

Right, back to our question of several paragraphs ago. How can you possibly write a complex program like an arcade game using simple instructions to move data around and do simple maths to it? Well, although the CPU's instruction set is somewhat more complicated, the basic building blocks of programming are that straightforward.

Supposing you're looking at the code for an arcade game, for example, where a sprite is being moved

around the screen under joystick control. It's easy to see that the current position of the sprite on the screen can be stored as a number, because the screen is a grid of little squares.

The top-left corner of the sprite might be at 100 across and 40 up, for example. So that number will be stored in RAM somewhere.

Suppose we want to see whether the joystick has been used to move the sprite sideways. The first instruction in your program would check the joystick input to see if the joystick had been moved to the right. If so, the CPU might fetch the position of the sprite from RAM and store it in a register. It might then set the number in another register to 5, then add the two registers together. Then it could store the new number in RAM in place of the old position of the sprite across the screen. It could then ask the output parts of the computer to display the sprite on the screen again in the new position, 105 across and 40 up.

It's a simple and entirely inaccurate example of what goes on, but it shows how two simple Assembler instructions, 'move' to move data between RAM and registers on the CPU, and 'add' to add figures together, can go to make up the basics of a program.

It becomes fairly obvious at this stage that there's a couple of things we've ignored quite vastly. After the CPU, which does all the work, and RAM, which stores all the data, the two most important parts of a computer are the input and output.

Input is anything that enters data into the computer: the most obvious input devices are the internal disk drive, the keyboard and the mouse or joystick.

Output is anything that takes data from the computer: the disk drive again, if you're saving data to it, the screen display and a printer, for example.

Any piece of equipment that the computer inputs data from or outputs data to is known as a 'device'.

Collecting data from or sending data to these devices is handled by the CPU in more or less exactly the same way as collecting data from or sending data to RAM. In other words, it's all done by instructions in the CPU, which must be written into the programming code.

It may seem, for example, that the joystick is controlling a program; for this reason, you may imagine that the CPU is forced to listen to what the joystick is trying to tell it. But no. In fact, the CPU is checking every so often to see if there's any input from the joystick, and only when it's told to by the program.

Because it all happens so quickly, you don't really notice this effect. Most games will be checking the joystick round about 25 times every second. That's because the animation which makes the screen display appear to move involves displaying 25 slightly different screens every second. So every time it draws a new screen, the game program needs to know if you're trying to move the sprite that's under your control.

It's easy to see that loading data from disk is also handled by an instruction in the program. Data on a disk is stored with addresses that are quite similar to RAM addresses, so a program instruction to the CPU might tell it to load data from a particular address on the disk and put it in a particular address in RAM.

One important question that might pop into your head at this point is what happens when you first switch your Amiga on. If there's no program in RAM yet to tell the CPU to load data from the disk, how does it know to do it?

Well, this is the job of the Kickstart chip in your Amiga. Kickstart is what's known as a ROM (Read Only Memory) chip. This is very much like a RAM chip, except that all the data in it is permanent and is fixed when the chip is made. It doesn't need a constant supply of electricity to prevent it losing its data. The

Continued on Page 43

What are Workbench, the CLI and the Shell?

As you'll know if you've read the main piece of this article, the Kickstart chip leaps into action when you switch the Amiga on, running several programs through the CPU to set up the basic workings of the Amiga.

The most important functions of these programs are threefold: to get the screen display working; to enable programs to load from the disk drive; and to enable programs to read and write data from and to the disk drive. They're known collectively as the 'operating system' (o/s for short) or, more specifically, as AmigaDOS (Amiga Disk Operating System).

The first thing most games will do is 'kick out the operating system', clearing the RAM of all the operating system's programs. This is because games programmers only need to use a few of its features, and those they can do more efficiently themselves; and because they need all the RAM they can get in order to do lots of whizzy things. Some games, on the other hand, particularly those that use a hard drive, do use the operating system, and this is known as 'o/s legal' software.

So what's the Workbench disk for, then? Well, basically it provides what's known as a 'user interface'. All this means is that it enables you to use all the programs of AmigaDOS.

The Workbench disk gives you two different ways of controlling AmigaDOS: either from the Workbench screen or from the Shell. Both are dif-

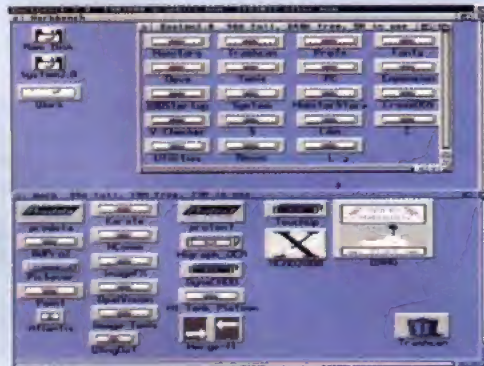

The Workbench disk's most obvious feature is the Workbench screen itself. This is a 'graphical' interface which lays everything out in front of you.



The more complicated alternative is the Shell. Here, nothing is shown and you have to be able to call things by their right names in order to do anything with them.

ferent kinds of interface. The Shell is also known as the CLI, which stands for Command Line Interface, and it's so called because you use it by typing in lines of commands, then pressing the Return key to enter them.

The CLI way of doing things is tricky, firstly because you have to remember all the commands and secondly because you have to spell everything absolutely correctly, put everything in the right

order and use special characters like spaces, colons and backslashes in all the right places. This is known as 'syntax' - get your syntax wrong and the CLI won't understand you.

Because the CLI is difficult, the Workbench screen was developed as an alternative. This is what's known as a 'GUI' (Graphical User Interface) or a 'WIMP system' (Windows, Icons, Mouse and Pull-down menus) and the idea is that it's much more 'user-friendly' and simple, because everything is shown to you on the screen as little pictures. This makes the depths of the computer seem much less mysterious and off-putting.

We won't go much further into Workbench and the Shell right now. It's just worth pointing out, though, that they are both there to help you deal with disks and what's on them: the main functions include things like formatting and copying disks, copying files and programs from one disk to another, and deleting old, unwanted files. That sort of thing.



X-BACKUP PROFESSIONAL

A1200 HARD DISKS
AND MEMORY
UPGRADES NOW
AVAILABLE.
PHONE: 061
724 7572
NOW

Existing owners, please phone for upgrade details.

X-BACKUP PRO

X-BACKUP PRO

**THE BEST
AMIGA DISK
COPIER.
GUARANTEED**

Unlike other copiers,
X-Backup is
fully automatic and
NO technical
knowledge is
needed. Even a
beginner can use
X-Backup!

For Amiga A500, A500+, A600, A1200,
A1500, A2000, A3000 & A4000

INCLUDES NEW
MULTIFUNCTION
'CYCLONE'
CARTRIDGE
FOR INCREASED
COPYING POWER

**X-BACKUP PRO is the most powerful
disk duplicator/utility package ever
designed for the Amiga.**

**For duplicating your original
software, X-BACKUP PRO is a must,
however it offers so much more.**

HOW TO ORDER X-BACKUP PRO:-



Telephone our sales hotline with your credit
card details for immediate despatch.

061 724 7572

Send a cheque or postal order for £40.99
made payable to SIREN SOFTWARE to
Siren Software, Wilton House, Bury Road,
Radcliffe, Manchester M26 9UR.



- ✓ Copies virtually all known disks, far more than any other copier available.
- ✓ Also backs up hard disks. Ideal for A600HD owners.
- ✓ Full file management/copying utility.
- ✓ Optimises data for faster loading.
- ✓ Formats, repairs, verifies. More than just a copier!
- ✓ Includes the new CYCLONE cartridge.
- ✓ Official U.K. version. Includes 8 page manual.

GUARANTEE:- X-BACKUP PRO is the most powerful disk copier available for the Amiga. If at the time of purchase, you can find a superior copier, we will REFUND YOUR MONEY. Can any other copier offer you that?

How pictures on the screen work

AMIGA FORMAT

42

FEBRUARY 1993

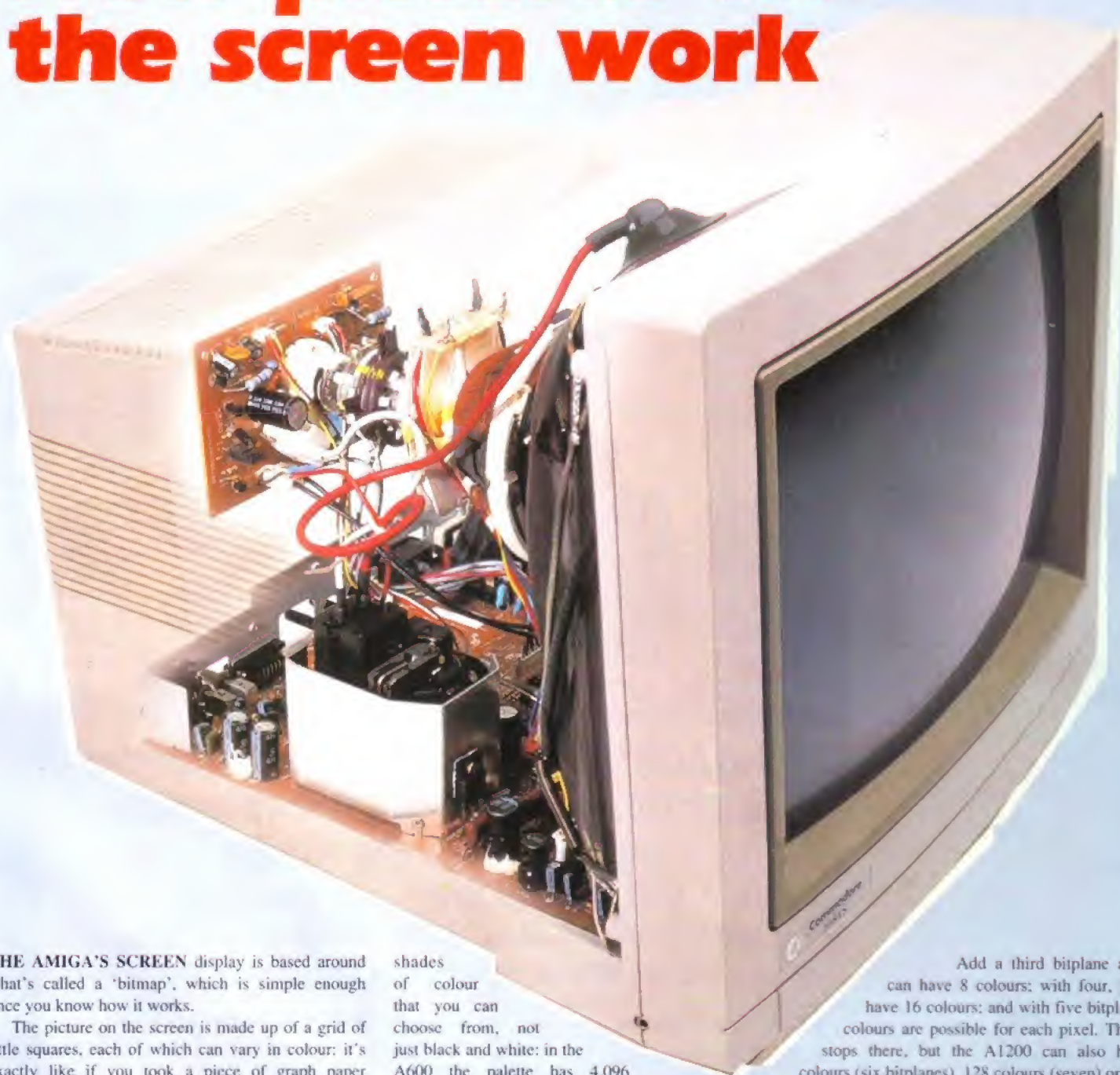

THE AMIGA'S SCREEN display is based around what's called a 'bitmap', which is simple enough once you know how it works.

The picture on the screen is made up of a grid of little squares, each of which can vary in colour: it's exactly like if you took a piece of graph paper and coloured in each little square with a felt-tip pen. Each little square is known as a 'pixel', which is short for 'picture element'. Try painting in *Deluxe Paint* with the smallest brush and the 'magnify' window on and you'll see that you can change the colour of each pixel individually. Let's see how the Amiga stores the colours.

Imagine a simple case where each pixel could be black or white. Each pixel could be represented by a single bit, a binary 1 or 0: 1 for black, 0 for white, say. The Amiga holds the screen in its memory as a list of what colour each pixel is, starting from the top-left of the screen and working along each row until it has to start again one line down. This is what the bitmap is: effectively, just a map (like a road map) of the bits that represent the screen colours.

The Amiga has a 'palette' of set colours and

shades of colour that you can choose from, not just black and white: in the A600 the palette has 4,096 colours and in the A1200 it has 16,777,216. You can set whichever one of these colours you like to be represented by the binary 1s and 0s, so in our simple example, instead of black and white you could just as happily have blue and yellow.

If you want more colours, you need to add more bits for each pixel. To display four different colours, for instance, you'd use two bits: your colours could then be represented by 0,0 or 1,0 or 0,1 or 1,1.

To represent this in memory, the Amiga imagines that a second bitmap is placed behind the first one, almost as if you've got two pieces of graph paper behind your screen. To get the colour of a pixel, the Amiga must read 1s and 0s from the relevant position on both bitmaps. In actual fact, when there's more than one, the bitmaps are called 'bitplanes' and the whole collection of planes is called the bitmap.

Add a third bitplane and you can have 8 colours; with four, you can have 16 colours; and with five bitplanes, 32 colours are possible for each pixel. The A600 stops there, but the A1200 can also have 64 colours (six bitplanes), 128 colours (seven) or a maximum of 256 colours (eight bitplanes).

But it doesn't stop there. The A600 has two extra colour 'modes' built in. EHB (Extra Half Brite) uses a clever programming trick to let you use 64 colours in total, though only 32 of them are real and the other 32 are the same colour, but exactly half as bright.

HAM (hold and modify) works on the basis that each colour on a TV is made up of red, green and blue: instead of defining a separate colour for each pixel, it allows some colours to be like the last one but with the amount of red, green or blue in the colour changed. In this way it lets you use all 4,096 of the A600's colours to paint with.

Finally, the A1200 has a new version of HAM called Super HAM. It works in exactly the same way, but because the A1200 allows eight bits per pixel and has many more colours in its palette, it can modify

The complicated bit at the back of the telly with all the wires is the business end. Here are the electron 'guns', which push out beams of red, green and blue electrons in separate streams. From these three colours of light, any other colour can be made.

The beams are bent to the appropriate point on the screen by a circle of electromagnets, also towards the back end of the TV tube. The beams then pass through a wire mesh with lots of little holes in, to make the picture more accurate, before finally hitting the phosphor coating on the back of the screen to make a single little dot on the screen. Each dot is called a pixel.

The monitor draws a whole screen, dot by dot, every 1/50th of a second. It starts off at the top left and draws a line of dots along the screen to the right, which is known as a 'scan line'. This is quite an important term, because the Amiga's custom chips can change the colour of the background or even change the whole palette at the end of each scan line.

Another useful term is 'frequency'. Because the monitor draws a new picture every 1/50th of a second, it is said to have a frequency of 50Hz (Hertz meaning simply 'cycles per second'). Some screen modes on the Amiga 1200 do use a different frequency, and therefore need a 'multi-scan' monitor - one that can work at different frequencies - in order for you to use them.

Lastly, if you know how a monitor works it helps explain why RGB colour video signals are the best quality. It's simply because messages to the Red, Green and Blue guns are carried separately. In a Composite signal they are all mixed up and then have to be de-scrambled by the monitor, which results in some loss of quality.

the red, green and blue more. The result is that Super HAM allows you to use 262,000 colours on the screen.

Apart from the number of colours used, the other thing you can decide about your screen display is the 'resolution'. In a normal low-resolution Amiga screen, there are 320 pixels across the screen and 256 down (that's 81,920, fact freaks!). If you make them smaller, you can fit more of them on the screen. The advantage of this is that the smaller the pixels are (the higher the resolution), the less noticeable it becomes that the picture is made up of little blocks.

The A600 also has medium resolution, in which the width of the pixels is halved, to give you 640 pixels across by 256 down, while high resolution halves the height too, giving 640 by 512. Both these have a maximum of 16 colours rather than 32.

There's also Interlace, which gives 320 by 512 and can be used with anything up to 4,096 colours. This is a bit clever, because it works exactly the same way as a TV picture, making the Amiga ideal for video use.

The A1200 has all sorts of extra resolutions, the highest of which are limited to only four colours, but there's too many of them to list here!

Kickstart chip contains a number of small programs that it squirts to the CPU when you switch your Amiga on. These programs first wake up all the input and output devices, then run a check on all the chips and bits and bobs to make sure that everything's working.

If all is well, it displays an animation on the screen asking you to insert a disk in the disk drive. If there's anything wrong with the system, however, the Kickstart programs will display a single colour on the screen: which colour it shows will help an engineer analyse what's wrong with the machine.

Kickstart then runs a program that tells the CPU to check if a disk is put in the disk drive. It will sit there running this program until you do put a disk in. The program then tells the CPU to load data from a particular place on the disk and check it.

This particular place is called the 'boot block' (how data is organised on a disk is described in the panel about disks and disk drives). If the data in the boot block is not right, the CPU will ignore it, because this obviously isn't a boot disk (one that can load a program into the Amiga). If it is right, the data in this block will run a program that loads data from the disk into RAM and then runs the program. Simple enough!

The programs contained on the Kickstart chip are loosely described as AmigaDOS (the Amiga Disk Operating System) because they prepare the Amiga to load a program from the disk drive.

Recent releases of Kickstart (version 2.05 in the A600 and version 3 in the A1200) come on a larger chip which can store more data - 512K as opposed to 256K. Thanks to this extra storage space, the Kickstart chip is also able to store some CLI commands. This has two major advantages: compared with the CLI commands on the Workbench disk, these load

• Important chips in the Amiga are: Paula, Agnus and Denise in the A600 - though in the A1200, Agnus is replaced by Lisa and Denise by Alice •

much quicker, and you don't have to have the Workbench disk in the drive to use them. A full explanation of Workbench, the Shell and CLI commands is featured in yet another separate panel.

Right, back one step. We were talking about input and output. Obviously, the CPU can read from and write to input and output devices in just the same way it can read from and write to RAM, but there is one important difference.

Each device talks its own language, and the CPU doesn't have the capacity to translate. So all the negotiations are handled for it by a control chip, which happens to have a name. This chip was called Gary in the A500, but in the A600 and A1200 goes by the name of Gayle.

Gayle handles reading data from and writing it to all input and output devices, including the external disk drive, the serial and parallel ports and the PCMCIA and IDE connectors. All these are explained in a separate panel.

That Gayle does this job is round about all you need to know about her, but there are some much more important chips in the Amiga that also have names. These are Paula, Agnus and Denise in the A600 - though in the A1200, Agnus is replaced by Lisa and Denise is replaced by Alice.

These three chips make up the custom chip set. The A600 features new versions of Agnus and Denise and so its chip set is called the Enhanced Chip Set or ECS, while the A1200 features an even newer set which is known by its Commodore version number as the AA chip set, or alternatively by its Commodore official title as the AGA (Advanced Graphics Array) chip set.

These custom chips are what make the Amiga so special. The important thing about them is that each one has its own set of instructions, just like the CPU, so they can also be programmed to do things. To make this happen, the custom chips also have to be able

Continued overleaf

The way a mouse works is pretty simple, and you can actually see it all when you take the ball out to clean it. (You do do that occasionally, don't you? No? Well you should).

Anyway, the basic idea is that a big ball rolls along the desktop. As it rolls, it presses against three rollers - one for up/down, one for left/right and the other one on a spring to push the ball against the other two. As the ball rolls, the rollers turn: and as the rollers turn, they click little microswitches. The Amiga can pick up these clicks and knows whether the mouse is being moved to the left, right, up or down, and by the number of clicks it knows how far the mouse has travelled. Simple, eh?



to access RAM directly, without consulting the CPU. This feature of the Amiga's architecture is called Direct Memory Access (DMA). It's to make DMA possible that the Amiga features two different kinds of RAM: Chip RAM and Fast RAM. The chips for each kind of RAM are exactly the same, however, the difference between the two being in where the addresses of a particular bit of RAM are.

The first 1Mb on an Amiga 600 is Chip RAM, and that's as much as it can have. Anything after that is Fast RAM. On the A1200, the first 2Mb of memory are Chip RAM and the rest is Fast.

Fast RAM gets its name because it's quicker for the CPU to access it: it doesn't need to see if the custom chips are getting in its way. Chip RAM is so called because the custom chips are allowed direct access to it. The advantage of having more Chip RAM is that it allows you to use more animation and more sampled sounds, because both these functions are handled by the custom chips.

Paula is the sound chip. It can act as a synthesiser, creating the electrical pulses that make up sounds. It also includes an important electrical circuit called the D-to-A (Digital-to-Analogue) convertor. This enables it to convert digital data into analogue sound – the pulses that make a loudspeaker vibrate and create noises as air waves. This gives the Amiga the ability to use 'sampled' sounds.

What is a sampled sound? Well, noises are waves in the air, and are created electrically by a current in a wire which pulses, pushing a cone of paper in a loudspeaker in and out by means of an electro-magnet. The electric signal that drives the speaker can vary in voltage, up and down, all over the place, so it's known as an 'analogue signal' – the amount of electricity is directly analo-

■ A sprite is simply any small object that moves around the screen over a background, like a spaceship in a shoot-em-up. Sprites can easily be drawn on the screen and moved around by the program ■

The joystick is the very simplest of devices. All it is is a rod (the stick bit) with a pivot of sorts at the bottom. As you push and pull the stick in different directions, the rod presses one of eight micro-switches – one for up, down, left, right and each of the diagonals – and each switch that is on sends a signal to the Amiga telling it that it is being pressed. Very easy.

gous to the amount it pushes the speaker cone. Sampling is exactly like the digital sound used by a CD player. A sampler checks the level of the electrical signal many times a second, and at each point converts it into binary data which can be stored by the computer.

The Paula soundchip can convert this binary data back into an analogue signal using the D-to-A converter, then send that signal to the stereo outputs on the back of the Amiga and hence to loudspeakers.

You can buy your own sound sampler – a good one can now be had for as little as £25 – and experiment with sampled sounds yourself. The sampler is a piece of hardware that connects to the parallel port on the back of the Amiga, and it includes an A-to-D (analogue-to-digital) convertor that translates the signals from whatever sound input you attach to it (microphone, hi-fi, video, whatever) into digital data. Sound samplers are controlled by software that comes with the hardware, and using the software you can also 'edit' your sounds – chop out bits you don't need.

Using another kind of software you can then write songs using your samples. This type of program is usually known as a sequencer because you use it to create sequences of notes. Paula has the ability to play back sounds at different 'itches' – high (treble) or low (bass) notes – varying across a full eight octaves of sound.

Paula also allows you to use four 'channels' of sound, which means that Amiga can play four different sounds at the same time, so you can use four different instruments (sounds) in the tune you create. The Amiga has stereo sound, so two of these channels go to each side of the stereo.

And that's really all you need to know about Paula and the Amiga's sound capabilities. Let's look at the other custom chips.

The most important thing about Alice and Lisa is that they are the heart of the Amiga's graphics. Built in to these chips are the Amiga's display resolutions (which are explained in a separate panel).

Agnus includes two 'co-processors', which are like mini-CPU's with their own instruction set – Agnus has 256 logic instructions. The co-processors go by the unlikely names of the Blitter (short for Block Image Transferer) and the Copper (short simply for co-processor).

The Copper allows split-second control over the scanning beam on the monitor. We've explained monitor displays in full in a separate panel, so take a look at that now. But briefly, here's an idea of how it works.

The TV picture is built up by a beam which scans across a line from the left of the screen to the right – each line is called, obviously enough, a scan line. In a low-

resolution display, to take the simplest example, the TV needs 256 of these scan lines to create a complete picture, and it's creating one complete picture every 1/25th of a second. This means a new scan line is started every 1/6400th of a second, which shows you how quickly the Copper is working. At the start of any scan line, the Copper can change what image is being drawn on the screen. This means the Amiga can do what's known as a 'split-screen display', the most obvious example being if you load a program like *Deluxe Paint* from the Workbench – using the left mouse button on the title bar, you can drag the *Deluxe Paint* screen up and down, revealing the Workbench screen behind.

The other thing the Copper can do is switch one of the screen colours on each scan line. This effect is programmed using a bit of code known as a 'Copper list' and it changes the background colour to a new one on each line – it's what gives the rainbow-effect skies and backgrounds in arcade games such as *Zool*.

The Blitter is prepares images to be drawn on screen. It can take three graphic inputs and combine them to create one output, which is what makes possible the concept of 'masking'. In a game, for example, where a sprite is drawn over a background, the whole thing's organised in a very specific way: the background is drawn first, then a cut-out 'mask' (like a shadow of the sprite) is put over it, then the sprite can be drawn where the mask is.

The other chip, Denise, is the one that handles the actual display of images, converting the bitmap information from memory into an actual screen display. Denise also looks after the collision detection in games and handles hardware sprites. So what's a hardware sprite?

Well, a sprite is simply any small object that moves around the screen over a background, like a spaceship in a shoot-em-up. Sprites can quite easily be drawn on the screen and moved around the screen by the program, but a programmer can also define a number of hardware sprites. All he has to do with these is tell the Amiga it's a sprite, and Denise will do the rest of the work of drawing them and moving them around the screen. The mouse pointer on the Workbench screen is a good example of a hardware sprite.

The advantage of hardware sprites is that they are quicker, but the disadvantage is that there is a limit to how many you can have on the screen and how big they can be. With software sprites, there is no such limitation.

There's one last thing worth a mention on the custom chip front, and that's again to do with architecture. The new AA chip set in the 1200 is full 32-bit, which improves the speed. As we said earlier when talking about the CPU, the 14MHz clock speed and the 32-bit data bus should make the 1200 about four times as fast as an A500, but the 32-bit chip set adds a little extra oomph – Commodore's tests reckon it to be about five times as fast.

So that's how the custom chips fit in. Because they have their own programming instructions, they give the Amiga many of its advantages over other computer systems. Clever stuff. ☺





ASHCOM

DESIGN & DEVELOPMENTS LIMITED



APEX WILL BACK-UP ALL KNOWN SOFTWARE - GUARANTEED !!!
ESSENTIAL FOR ALL AMIGA A500/A500+, A600 + A1200 USERS

new!!

APEX

£34.95
INCLUDING P/P & VAT

THE MOST POWERFUL DISK BACK-UP SYSTEM SINCE THE MAC II
THERE IS NO SOFTWARE THAT CANNOT BE COPIED USING APEX

FEATURES:

THE MOST COMPREHENSIVE BACK-UP SYSTEM EVER DESIGNED FOR THE AMIGA INCORPORATING AST (ADVANCED SYNCRO TECHNOLOGY) - EASY TO USE QUICK & EASY TO INSTALL - BACKS UP OTHER FORMATS IBM, ATARI, MAC ETC EASY TO FOLLOW ILLUSTRATED MANUAL WITH COPYING TECHNIQUES

ORDER APEX NOW & BACK-UP ALL YOUR SOFTWARE - GUARANTEED

ADDAX - ADDHARD

THE ULTIMATE RAM EXPANSION
AMIGA A500/A500PLUS

AMIGA
DOMINATION

COMPLETE HARD DRIVE SYSTEM FOR THE
AMIGA A500/A500PLUS

FEATURES

- EXTERNAL FITTING
- JUST PLUGS IN!!!
- AUTO-CONFIGURE FOR 2Mb-4Mb-8Mb
- BUS THROUGH PORT
- ULTRA LOW POWER
- NO EXT PSU REQUIRED
- FULLY BUFFERED ADDR AND DATA BUS
- ZERO WAIT STATES
- GURU FREE!!!
- SLIMLINE CASE
- STYLED TO THE AMIGA
- HIGH DENSITY DRAM
- LATEST TECHNOLOGY
- ALLOWS CREATION OF LARGE & FAST RAM DISKS

WILL NOT INVALIDATE
COMMODORE WARRANTY

**JUST PLUG IN &
AWAY YOU GO!**
- SIMPLE ! -



ADDHARD - ADDAX COMPATIBLE WITH ALL AMIGA A500'S!!

OUTSTANDING FEATURES

- NEW QUANTUM DRIVE
- VERY HIGH SPEED LOW POWER
- SMALL SLIMLINE UNIT
- VERY LOW NOISE OPERATION
- NO EXT PSU REQUIRED
- BUS THROUGH PORT
- AUTOBOOT 1.3/2.04
- COLOUR MATCHED
- STYLED TO THE AMIGA
- FACTORY SET - EASY TO INSTALL!!
- EASY TO USE!!
- WILL NOT INVALIDATE WARRANTY
- SETUP SOFTWARE & HD UTILS DISK

**HIGH QUALITY
LOW PRICES!**

AX502	2MB	EXP	£125	PARTIALLY POPULATED UNITS EXPAND TO 8MB WITH 2MB INCREMENTS SOLD AT £69.95 PER 2MB
AX504	4MB	EXP	£175	
AX508	8MB	EXP	£285	

ADDHARD42	42MB	£275
ADDHARD85	85MB	£375

APRIL AMIGA FORMAT - "BEST BUY - HIGH QUALITY LOW PRICE"

AMIGA A500 1/2 MEG UPGRADE - £17.95 CLOCK £19.95

1.3/2.04 ROM SHARER £12.95 - AUTO-JOYSTICK SWITCHER £15.00

NEW!

AMIGA A600 1MB EXP £42.95

CLOCK £44.95

GAME-BUSTER

AT LAST THE CHANCE TO SLOW DOWN YOUR GAMES OR FREEZE THEM SO YOU CAN BEAT THEM - PLAY TO WIN! PLUGS INTO A500 PORT-EASY-WITH SLOWDOWN ADJUST!

£24.95

ALL PRICES INCLUDE VAT & P/P - NORMALLY DESPATCHED WITHIN 48HRS - 1 YEAR WARRANTY

FOR FURTHER INFORMATION ON OUR PRODUCTS SEND A SAE OR CALL OUR HELPFUL SALES DEPT. YOU CAN ALSO PURCHASE OUR PRODUCTS FROM YOUR LOCAL DEALER BY ASKING HIM TO CALL US DIRECT - NOW.

Only from ASHCOM, DEPT AF2, 10 The Green, Ashby-De-La-Zouche, Leicestershire LE6 5JU

MON-FRI 9.00-5.30
SAT 9.30-2.00

Telephone: (0530) 411485 (24hrs) Fax: (0530) 414433

MON-FRI 9.00-5.30
SAT 9.30-2.00

THE AMIGA CD CONSOLE

Commodore are committed to cheap, accessible, 'entry-level' Amigas and also to the idea of CD as the main storage format for entertainment software. They also believe that CD gives them the opportunity to oust the Japanese console giants. Put them together, and a CD-driven console seems a pretty viable option.

In favour of the Amiga CDC (CD console) is the fact that all CDTV software was developed to make use of a limited control system from the CDTV's infra-red controller, so the possibility of a keyboardless system, controlled perhaps by console-style joypads or infra-red versions thereof, is proven and workable.

The cost reduction of a keyboardless Amiga means this device could come out at £120-£150.

Expandability would definitely be the key, with all the standard Amiga interfaces on the back, including the capacity to add a floppy disk drive and a keyboard (around £40 and £50 respectively). A PCMCIA slot would also be vital. This fits with Commodore's long-term vision of the Amiga as a 'modular system'.

Like all new Amigas, the CDC would need to be based on the new A1200's specification, with 32-bit architecture, 68020 processor, the AA chip set and 2Mb of chip RAM as standard.

On the down side, though, it seems unlikely that Commodore will take this route. As the Amiga has developed, their speciality has very much become the world's best-selling home computer, with all its inherent creativity and productivity advantages. Plus Commodore UK boss Kelly Sumner has admitted in the past that his biggest mistake was the C64 console, a personal project of his which flopped totally. Still, it makes sense in so many ways that anything is possible...



THE A1000 PORTABLE

This is a bit of a dream machine, but it incorporates a number of ideas that are significant at the moment. Essentially this is an A1200 adapted for the arrival of the CD drive. Commodore have stated that they can fit a CD drive to an Amiga as cheaply as they can a floppy disk drive, so if they are committed to CD then an A1200 with built-in CD has to be the next logical step. It's likely to happen about a year after the release of the original 1200, probably in November this year, in time for Christmas.

The other obvious thing about this Amiga is it's portable, incorporating a fold-down colour LCD screen. There's never been a portable Amiga, though it seemed possible about a year ago, there was one the verge of release – but an American firm that proposed producing Amiga portables was warned off by Commodore in the US.

There are problems though. Power consumption in a portable is the key and the Amiga gets through a lot of power. Price is also a drawback – colour LCD screens are expensive.

One important aspect of the portable is a built-in power supply. Many computers have a power transformer built in to the case, so all you need to plug them in is a lead. We're not sure why Commodore haven't tried to include the power supply in the A1200, but it may be manufacturing costs and the need to meet consumer-protection regulations in a number of countries with widely differing standards could make it difficult.

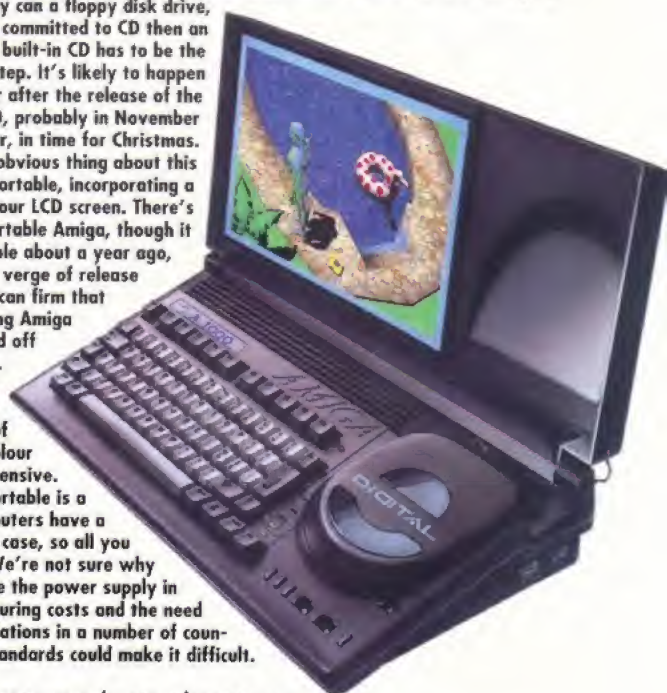

This a cross between a manifesto and an almanac.

Amiga Format's staff, the world's foremost Amiga commentators, set the agenda for what should – must – happen in 1993...

Visions of the

The Amiga Format Manifesto

1992 was undoubtedly Commodore's most impressive year for the Amiga. They introduced lots of new ideas that have a major place in the future, such as IDE, PCMCIA and the A1200's new standard. But they've also got a lot of plans for 1993, which is bound to be another big year of change.

Last issue, we asked 40 of the most important companies in the Amiga world what they thought about certain key issues. In some ways, many of the answers were disappointing: too many of them seemed to have too little idea of where Commodore are planning to take the Amiga.

So partly for their benefit and partly for yours, we thought it would be useful to identify the key Amiga issues and to state, here and now, what *Amiga Format* believes must happen. We'd also like to point out a few things to Commodore: you've had a great year, but there's more to be done yet, boys!

● CD MUST BECOME THE PREMIER STORAGE MEDIUM

Commodore are utterly committed to this and are prepared to 'lead the market' in the right direction. So are we. Only a few key UK game publishers seem to be aware of this to date.

Software on CD is proof against casual piracy and CDs are much cheaper to make than the console-style ROM cartridges. They also allow potential for much more impressive software, with massive storage capacity equivalent to over 600 floppy disks.

CD could also break the stranglehold of approval and licence fees with which Sega and Nintendo have been able to control the games software market. Something big is definitely going to happen and if you're not aware of CD, you're doomed.

● GAMES MUST COST £20 OR LESS

All the leading UK software houses who we've spoken to are already committed

to this concept. And it's going to be CD as a medium that will make it possible, this is because of the massively lower production costs and much shorter 'lead times' for manufacture.

The games publishers have enjoyed the boom in popularity of games on the piracy-proof console cartridges, but they have now come to realise that consumers dislike the high retail prices of cartridges, which is caused by the high cost of manufacture and the 'licence' system by which money goes to the console manufacturers.

The Amiga CD, as an 'open system' for which anyone can develop games, can remove these disadvantages and make the £20 brand-new game a standard.

● COMMODORE MUST ENSURE AMIGA CD IS AN OPEN SYSTEM

All CDTV discs currently have to be licensed and approved and use a variety of 'key code' in the boot. Not on. Commodore must resist the temptation to put any restriction on who can develop for the Amiga.

● PCMCIA IS FOR HARDWARE, NOT SOFTWARE

Many people seem to believe that the 'credit card' slot has been included so that cartridge-based software is an option. It's not. That would simply repeat all the problems that CD can sort out.

PCMCIA is an ideal way of adding extra hardware: a slim card can fit a 4Mb RAM expansion, backed by a battery if need be so that you can carry it around and retain the data. But RAM is just a start: fax/modems and even hard drives will soon come on cards.

PCMCIA cards are a cheap, compact and extremely convenient way of adding extra widgetry to the Amiga and we're right behind the idea.

Or, alternatively, the B4000. Whether or not it's true, there is a rumour that the top man at Commodore US was dissatisfied with the A4000, believing, impressive though it was, it didn't go far enough. Look at the price of the A1200 and compare it with the A4000 and you might be forced to agree.

Commodore in the US make no secret that they have a 'Triple A' chip set in development. We would envisage an A5000 based around this chip set would be a logical development in the middle of next year.

This chip set has only one place left to go as far as graphics are concerned, and that's a true 24-bit display – selecting from 16 million colours on the screen. This would give 256 shades of any colour, which is believed by experts to be sufficient to give a perfect representation of any picture.

Add in 16-bit 'CD quality' sound from a new sound chip and you have the perfect machine: there is nowhere else to go as regards graphics or sound. Other specifications would be similar to the A4000, with the 68040 chip on a removable 'master board' to allow immediate upgrade to Motorola's next generation of faster chips.

Inevitably, while IDE is the perfect solution for miniature hard drives, a return to SCSI2 is necessary in the A5000 as well, for the extra speed. Lastly, there must be an option for an internal CD drive. With the A2200 taking on the cheap PC market in homes and small businesses, the 24-bit A5000 would be the ideal graphics workstation for film, TV, video, DTP and the burgeoning multimedia presentation market. The A3000 and the A4000 could then be scrapped.

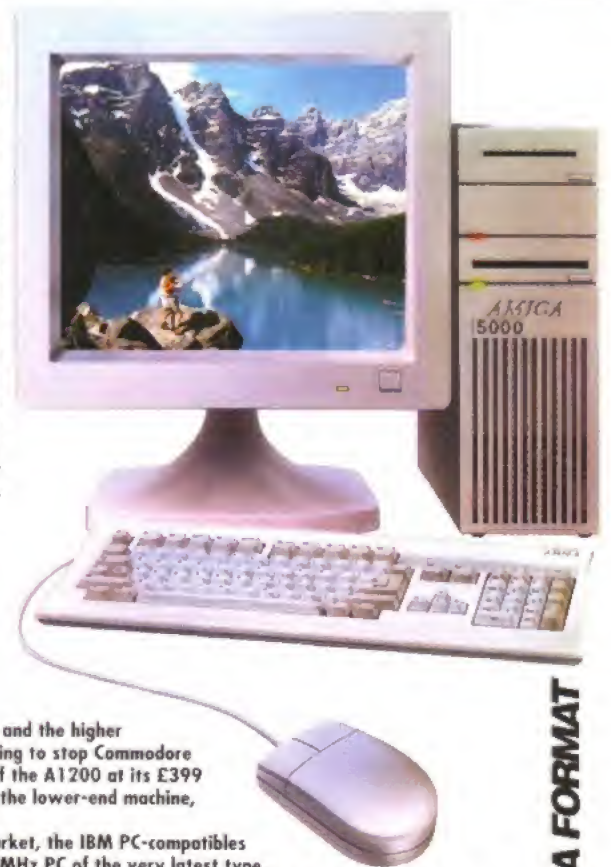

future

THE A2400

Commodore are adamant that a project they did have under way that went by the name A2200 has been abandoned, and that there is no need for a new mid-range Amiga – gradual price reductions in the A3000 and A4000 over the next year will, they insist, fill the gap. But is it that simple?

There's now an enormous gulf in price between the A1200 and the higher machines in the range, even if you consider that there is nothing to stop Commodore from fitting the AA chip set to the A3000. The specification of the A1200 at its £399 price make the A4000, which has limited advantages over the lower-end machine, seem ludicrously overpriced at £2,100.

As soon as you consider the mid-price computer market, the IBM PC-compatibles have to come into the equation. You can now get a fast 33MHz PC of the very latest type, with 256-colour VGA graphics, a hard drive built in and a monitor, all for £1,000 or so. Good, but surely an Amiga could compete?

Our 2400 would be aimed at doing just that. Start from the base of an A1200, put it in a case with room for a couple of expansion slots and give it a separate keyboard, at a cost of maybe £100 extra. Give it a faster 68030 processor with a co-processor (maybe £50 extra – it's surprisingly cheap), the high-density disk drive from the A4000 (another £50 above the basic unit) and fit it with a 40 Mb internal hard drive at a cost of around £100. Total cost £799 for a heck of a lot of computer.

There are other elements it may be possible to incorporate, such as the DSP (Digital Signal Processor) chip for improved sound, which Commodore considered fitting in the A1200 but were prevented from including because they wanted to keep the cost at £399. But this machine would offer an impressive competitor for PC-compatibles as well as offering an upgrade path for Amiga owners who want to move to a more business-like machine.

● MORE PEOPLE MUST GET HARD DRIVES

Commodore have done their best to encourage you, the owner, to get a hard drive by introducing IDE into the low-level Amigas. This makes it far easier, much cheaper and immensely more convenient to fit a hard drive.

A hard drive makes an enormous difference to your machine. Everything you do, with the exception of playing games and, in many cases, that too, becomes quicker and easier. Workbench and all your favourite programs load instantly and are much more usable. Don't hesitate – get a hard drive.

There is one problem Commodore must sort out, and that's warranties. IDE drives are easy to buy and fit yourself, but that's no use if your on-site repair warranty goes down the pan. One solution might be to firm up the system of official Commodore dealers and oblige these dealers to fit drives at minimal cost, reseal the warranty sticker, and supply drives to Wang, the company that handles warranty repairs, so that on-site maintenance is still possible.

● GAMES MUST SUPPORT EXPANSION HARDWARE

Two of the most common complaints about a game are 'It's great, but it comes on two disks and ignores my second disk drive' and 'I can't install it on my hard drive'. Irritating, we agree.

However, it will cease to be a problem when games are finally released on CD. In the long term, therefore, we have to say these two problems will cease to be an issue.

One that will come increasingly to the fore, however, is that software will need to support the whole range of Motorola 68xxx processors. There's no longer any excuse for any kind of program to fail when run with an advanced processor or a co-processor.

● ON WORKBENCH BEING INSTALLED ON ROM CHIP

There has been a movement in favour of the contents of the Workbench disk

being included on a larger Kickstart ROM. Not a good idea: it prevents the user customising it and upgrading easily to newer versions. Hard disks make Workbench perfectly useable.

● COMMODORE MUST INVESTIGATE INTERNAL POWER SUPPLIES

Most home-computer systems have an in-built power supply, so you can plug them straight in with just a lead. The Amiga still has that hideous power 'brick'. Why? The TV modulator has been incorporated in the machine, so why not the power supply?

● COMMODORE SHOULD RELEASE AN A2400

There's a clear demand for a next step up Amiga from the 1200, with a similar specification but potential for 'in the case' expansion. A specification for this machine is discussed in more detail above. We don't see why Commodore don't plan to produce one.

● THE A4000 SHOULD BE REPLACED BY A NEW MACHINE WITH THE 'TRIPLE A' CHIP SET.

Again, this is discussed above. The release of the A1200 has made the A4000 seem ludicrously expensive, but a full 24-bit graphics workstation with the new chip set in would almost certainly restore it to its position as the Rolls Royce of the Amiga world.

● SCSI MUST BE RECONSIDERED

The IDE drive in the lower-end home Amigas is an absolutely ideal solution, but the workstation market has different needs. SCSI not only offers faster hard drives, but also allows access to SCSI-connected graphics peripherals such as professional scanners.



Software Supreme

139 High Road Loughton
Essex IG1 4LT

OPEN
6 DAYS
10 - 6

Tel 081-365-0344
(All lines)
Fax 081-365 1650

3D Construction Kit 2	35.49	Dark Queen of Krynn	19.49	Links	23.49
A Train	25.99	Dark Seed	26.99	Links Bountiful HD	13.99
A.T.A.C.	23.49	Das Boot	10.99	Links Firestone HD	13.99
A10 Tank Killer	21.49	Death Knights of Krynn	19.49	Links Pinehurst HD	13.99
A390 Airbus	26.49	Demonsgate	22.49	Liverpool F.C.	16.49
ADI English (11-12)	17.99	Devious Designs	15.99	Lord of the Rings	20.49
ADI English (12-13)	17.99	Dithells Wonderland	16.49	Lord of the Rising Sun	15.99
ADI English (13-14)	17.99	Do Jo Dan	16.99	Lotus Turbo Challenge II	16.49
ADI English (14-15)	17.99	Double Dragon 3	16.49	Lotus Turbo Challenge III	16.99
ADI Maths (11-12)	17.99	Dread Noughts	23.99	Lure of the Temptress	19.99
ADI Maths (12-13)	17.99	Dune	19.99	M. Ditka Ult F/Ball	18.49
ADI Maths (13-14)	17.99	Dyna Blaster	19.49	M.1 Tank Platoon	19.99
ADI Maths (14-15)	17.99	Elf	16.49	Magik Pockets	15.99
ADI French (11-12)	17.99	Elivira II - Arcade	19.49	Magnetic Scrolls	17.49
ADI French (12-13)	17.99	Elivira II - Cerberus	22.49	Man Utd Europe	9.99
ADI French (13-14)	17.99	Elivira Mistress of Dark	21.99	Match of the Day	17.49
ADI French (14-15)	17.99	Enhanced	21.49	McDonald's Land	17.99
AD Sports Boxing	11.49	Epic	18.49	Meg Lo Mania	18.99
AD Sports Driving	11.49	Espania Games 92	19.99	Mega Fortress	16.49
AV Harrier Assault	24.99	European Football Champ	16.99	Mega Mix Master	27.49
Avadams Family	16.50	Eye of the Beholder	19.49	Megasports	15.99
Adv Tennis	16.49	Eye of the Beholder II	22.49	Megatraveller 2	20.99
Agony	15.49	F14 Tom Cat	18.99	Megatwins	16.99
Air Bucks	20.99	F15 Stealth Eagle II	15.99	Microprose Golf	23.49
Air Combat Aces	18.99	F17 Stealth Fighter	21.49	Midwinter 2	23.49
Air Support	15.49	F19 Stealth Fighter	19.49	Mig 29 Fulcrum	16.99
Air Warrior	23.49	F29 Retaliator	15.99	Might & Magic 3	22.99
Alcatraz	16.49	Falcon 3	26.99	Monkey Island	15.99
Alien Breed Special Edition	9.49	Fantastic Voyage	16.99	Monkey Island 2	22.49
Amazing Spiderman	16.49	Fascination	18.99	Monster Pack 2	16.99
Amos Easy	23.49	Final Fight	16.49	Moonfall	15.99
Amos Professional	54.49	Fire & Ice	15.49	Moonstone	19.49
Another Creator	36.49	Fire Force	16.99	Mystical	15.49
Another World	16.99	Flag	19.49	Myth	18.49
Apolya	16.49	Flashback	16.99	Navy Seals	15.99
Aquatic Games	16.99	Floor 13	19.99	Nebula 2	15.99
Aquavener	13.49	Football Crazy	16.49	Nigel Mansells World Champ 21	49.99
Archer Maclean's Pool	16.99	Formula 1 Grand Prix	22.99	Night Shift	16.49
Armour Geddon 2	16.49	Fort Apache	15.49	Noddy's Playtime	16.99
Arsenal FC	16.99	Free DC	18.49	No Greater Glory	23.99
Asbes of Empire	23.99	Fun School 3 (under 5)	16.99	Omar Sharifs Bridge	23.49
Assassin	16.99	Fun School 3 (5-7)	16.99	Operation Stealth	16.49
Asterix	22.49	Fun School 3 (7+)	16.99	Orbitus	12.99
B.A. I	22.99	Fun School 4 (5-7)	16.99	Ork	15.99
B17 Flying Fortress	7.99	Fun School 4 (7+)	16.99	Outlanders	19.49
Back of the Future 2	7.99	Fuzzball	13.99	PGA Coured Disks	10.99
Back of the Cosmic Forge	23.49	Gateway to Sav Frontier	18.49	PGA Golf Tour +	19.99
Barbarian 2	14.49	Gauntlet III	11.99	Pacific Islands	18.99
Barbarian Tale Trilogy	19.49	Global Effect	16.99	Palladin 2	19.49
Battle Chess II	15.49	Goblins	15.99	Paperboy 2	8.49
Battle Command	18.99	Gods	16.99	Parasol Stars	15.99
Battle Isle	13.49	Golden Shot	16.99	Pegasus	16.49
Battle Isle Data Disk	11.49	Graham Gooch Cricket	19.99	Perfect General	19.99
Battle Master	16.99	Graham Taylor	15.49	Pinball Dreams	16.99
Battle Toads	16.49	Gunship 2000	21.99	Pinball Fantasies	17.99
Beast 3	19.49	Harlequin	16.49	Pitfighter	8.49
Beast Master	16.49	Harpoon 1 Meg	19.99	Plan 9 Outer Space	18.99
Big Run	16.49	Heimdall	13.99	Plotting	15.49
Bill's Tomato Game	20.99	Heros Quest	16.99	Police Quest 3	22.49
Black of Prey	23.49	Hill Street Blues	15.49	Pools of Darkness	18.49
Bomb Crypt	15.99	Home Alone	20.49	Populus 2	17.49
Bonanza Brothers	14.99	Hook	15.49	Populus Sim City	16.99
Boston Bomb Club	16.49	Hostile Breed	16.49	Powermonger	19.49
Bountiful HD Scenery	13.99	Humans	17.49	Predator 2	9.99
CVS Air Combat	20.99	I Jones Fate of Atlantis	23.99	Premier	19.99
Cadaver	16.99	Ian Bothams Cricket	19.49	Premiere Manager	16.99
Cadaver The Play Off	10.99	Indy Heat	16.99	Prince of Persia	15.99
California Games II	16.49	International Sports Challenge	16.99	Pro Tennis 2	18.99
Campaign	20.99	Ishar Legend Fortress	20.49	Pro Tennis Tour 2	15.99
Carl Lewis Challenge	15.49	J. Madden Football	16.49	Proflight	29.99
Castle of Doctor Brain	17.49	Jaguar XJ220	16.49	Project X	16.49
Castles	16.49	Jim Power	16.99	Prophecy	17.99
Catch - Em	16.49	Jimmy White Snooker	16.99	Push Over	15.99
Centurion	16.49	John Barnes Europe/Ball	15.99	R Type 2	14.99
Championship Manager	16.49	Kick Off 3	16.49	RBI 2 Baseball	12.99
Chaos Engine	16.99	KGB	19.99	Railroad Tycoon	22.49
Chase H.Q. 2	14.49	Kid Gloves II	16.49	Reach for the Skies	19.49
Cisco Heat	6.99	Killing Game Show	8.49	Realms	22.99
Civilization	23.49	Kings Quest IV	22.99	Red Baron	22.49
Code Name Assassin	16.99	Kings Quest V	15.99	Red Zone	15.99
Conflict Korea	23.99	Knight of the Sky	21.49	Rise of the Dragon	24.49
Conquest for the Longbow	21.49	Knightmare	18.99	Risky Woods	15.99
Contraptions	16.99	Lawnmower Man	16.99	Road Rash	16.99
Cool Croc Twins	15.99	Lazer Squad 2	16.99	Robin Hood	15.99
Cool World	16.99	Leander	15.99	Robocod	15.99
Cover Girl Poker	15.49	Legend	18.49	Robocop 2	14.99
Covert Action	23.49	Legend of Valour	24.49	Robocop 3	15.99
Crazy Cars III	15.49	Lemming Double Pack	19.99	Robosops	16.49
Creatures 2	16.49	Lemmings	15.99	Rodland	16.49
Cruise for a Carcase	15.99	Lemmings 2	20.99	Rome AD 92	20.99
Curse of the Azure Bond	20.49	Lemmings Data Disk	13.49	Rubicon	16.99
Curse of Enchantia	22.99	Lemmings Stand Alone	15.99	Rugby World Cup	8.49
Daily Double Horse Racing	13.99	Lethal Weapon 3	16.49	Rules of Engagement	16.99

BUDGET SPECIALS

3D Pool	6.99	Manic Minor	7.99
Advanced Fruit Machine	6.99	Michael Jackson	
After Burner	6.99	Moonwalker	6.99
Altered Beast	6.99	Midnight Resistance	6.99
Atomino	8.49	Moonshine Races	6.99
Awesome	8.99	Narc	6.99
Baal	5.99	New Zealand Story	6.99
Bards Tale 3	8.49	Operation Thunderbolt	6.99
Batman the movie	6.99	Operation Wolf	6.99
Beach Volley	6.99	Ostrun	6.99
Blood Money	6.99	Pacmania	8.99
Boulderdash	6.99	Pang	6.99
Bubble Bobble	6.99	Panza Kick Boxing	6.99
Cabar	6.99	Pipe Mania	6.99
California Games	6.99	Platoon	5.99
Captive	7.99	Predator	6.99
Carrier Command	6.99	Pro Tennis Tour	6.99
Cartilage	7.99	Puzznic	6.99
Celtica GT4 Rally	6.99	R Type	6.99
Centrefold Squares	6.99	Rambo 3	6.99
Chase 4 HQ	6.99	Resolution 101	6.99
CJ in the USA	7.99	Robocop	6.99
Cloud Kingdom	6.99	Rocket Rangers	8.99
Colossus Chess	6.99	Rolling Ronnie	9.99
Conflict in Europe	7.99	Run the Gauntlet	6.99
Crackdown	6.99	Shadow of the Beast	6.99
Crazy Cars	6.99	Shadow Warrior	6.99
Days of Thunder	7.99	Sherman M4	6.99
Defender of the Crown	7.99	Shindor	6.99
Deluxe Strip Poker	6.99	Shoot em Up	7.49
Double Dragon 1 or 2	6.99	Shuttle Puck Cafe	6.99
Dragon Ninja	6.99	Sky or Die	8.99
Emlyn Hughes Soccer	6.99	Sleeping Gods Lie	6.99
F16 Combat Pilot	6.99	Starglider 2	6.99
Fantasy World Dizzy	5.99	Storm Trooper	6.99
Gauntlet 2	6.99	Strike Force Harrier	6.99
Gazza 2	7.99	Stunt Car Racer	6.99
Ghost Busters 2	6.99	Super Hang On	6.99
Ghouls & Ghosts	6.99	Super Off Road	8.99
Go for Gold	8.99	Supercortex	6.99
Golden Axe	6.99	Switchblade	6.99
Hard Drive	6.99	Switch Blade 2	6.99
Head over Heels	6.99	Swiv	7.99
Hitch Hiker's Guide	8.49	Titus the Fox	9.49
J Khan Squash	6.99	Toobin	6.99
James Pond	6.99	TV Sports Football	5.99
Jet Set Willy	7.99	Ultimate Ride	6.99
John Lowe Ult Darts	6.99	Untouchables	6.99
Kid Gloves	5.99	Vigilante	6.99
Last Ninja 3	7.99	War Zone	6.99
Lombard RAC Rally	6.99	Waterloo	6.99
Lotus Esprit	6.99	Wizball	6.99
Manchester Utd	6.99	Xenon 2	7.99

COMPILATIONS

Award Winners	16.99	Power Pack	14.99
Air Combat Aces	18.99	Rainbow Collection	13.99
Air Land & Sea	23.99	Raving Mad	17.99
Bitmap Bros Vol 1	16.99	Soccer Mania	11.99
Bitmap Bros Vol 2	16.99	Super Fighter	16.99
Board Genius	17.49	Super Sim Pack	21.99
Cartoon Collection	16.99	Super Heroes	17.49
Dream Team	16.99	Sports	20.99
Fantastic Worlds	24.99	Strategy Master	19.99
Flight Command	14.99	Test Drive 2 Collection	20.99
Head to Head	24.99	4 Wheel Drive	19.99
Hollywood Collection	9.99	Quest for Adventure	23.99
Hot 2 Handle	18.99	Quest & Glory	21.49
Max Extra	11.99	Movie Stars	12.99
Monster Pack 2	16.99	Phantasia Bonus Edition	12.99
Ninja Collection	15.99	World Cup 90	9.99
Psychos Soccer Collection	18.99		

24 Hour
Ordering Service

Phone
for
Free Catalogue

Please make cheques & P.O.'s payable to **SOFTWARE SUPREME**
P & P £1 per item U.K. Elsewhere £3 per item.
New titles sent as released and subject to price reviews.

Title	Price	Name	
.....	Address	
.....	
.....	Tel
.....	Card No	Exp Date
.....	Access	PO
.....	Visa	Ch
.....
.....

For which computer? P & P TOTAL

KXP-4410 LASER PRINTER

KXP-4430 LASER PRINTER



WORDSWORTH COMPLETELY FREE!
WITH PANASONIC LASER PRINTERS
The writers choice. The ultimate word processor for AMIGA computers
NORMAL RRP £129.99 inc. VAT

Once again Indi have joined together with Panasonic to offer all Amiga owners the most outstanding Laser Printer offer ever. We are now able to offer high quality, professional laser printing at very affordable prices. We are also giving away a free copy of Wordworth with every Panasonic Laser Printer purchased (RRP 129.99). Whether you're looking for a laser printer to handle word processing, DTP, presentation or complex graphics applications - the Panasonic range offers you the power to meet your requirements.

KXP-4410

- 5 pages per minute
- 28 resident fonts
- Optional 2nd input bin (total printer capacity 2x200 sheets)
- Low running costs
- Parallel interface
- Optional memory expansion to 4.5Mb

(0.5Mb as standard)
• HP Laserjet II Emulation
RRP £992.00
INDI PRICE
£549.99 inc. VAT
WORDSWORTH COMPLETELY FREE WITH LASER PRINTERS

KXP-4430

- Satinprint (optimum resolution technology)*
- 5 pages per minute
- HP Laserjet III Emulation, PCL 5
- 8 scalable fonts & 28 bitmap functions
- Optional 2nd input bin (total printer capacity 2x200 sheets)
- Optional memory expansion to 5.0Mb (1Mb as standard)

RRP £1286.00
INDI PRICE
£859.99 inc. VAT
WORDSWORTH COMPLETELY FREE WITH LASER PRINTERS
* (Satinprinters use optimum resolution technology to produce truly outstanding print quality. This software technique smooths away traditional jagged edges on curved characters and lines by varying the printed dot size and position).

AS PART OF OUR POLICY OF CONTINUAL PRODUCT DEVELOPMENT AND REFINEMENT, WE RESERVE THE RIGHT TO CHANGE SPECIFICATIONS OF PRODUCTS ADVERTISED. PLEASE CONFIRM CURRENT SPECIFICATION AT THE TIME OF ORDERING.

ORDER FORM

BY POST — simply fill in the coupon below.
BY PHONE — ring 0606 43860. After 6.00pm each day your call will be answered by answerphone. If you would like to place an order have all details at hand including Credit Card.
SEND YOUR ORDER TO: **AF0193**
INDI DIRECT MAIL, FIRST FLOOR OFFICES,
85 WITTON STREET, NORTHWICH,
CHESHIRE CW9 5DW.

Please send.....
Price..... + £5.00 Delivery
I enclose cheque/PO for £.....
or charge my Access/Visa No.
Expiry date /
Signature.....
Send to Name.....
Address.....
Daytime Tel.....
Postcode.....

TEL: 0606 43860 • FAX: 0606 43825

ANALOGIC
ANALOGIC
ANALOGIC

Analogic Computers (UK) Ltd

Unit 6, Ashway Centre,
Elm Crescent
Kingston-upon-Thames
Surrey KT2 6HH

Telephone Mon-Fri 9am-7pm
Sat 9am-5.30pm

081-546 9575

Tel/Fax: : 081-541 4671

REPAIRS WHILE-U-WAIT !!

- * AMIGA A500 REPAIRS WITHOUT DIAGNOSTIC FEES
- * FIXED CHARGES
- * FAST TURNAROUND
- * MANY REPAIRS DONE WHILE-U-WAIT
- * WE PROVIDE PICK-UP SERVICE FOR REPAIRS FOR ONLY £5.00 + VAT

£49.95
including NEXT DAY
DELIVERY by
COURIER SERVICE

COMPUTERS

A600.....POA
A600 + HD.....POA
A1200.....POA

MONITORS

CM 8833II.....POA
SC 1435.....£199.95
Philips 15" TV/monitor, remote control + scart cable.....£239.00
Philips 15" TV/monitor, as above plus Fast text.....£269.00

FLOPPY DRIVES

1 Meg 3.5" internal.....£39.95
1 Meg 3.5" external.....£59.95

ACCESSORIES

Amiga 512K RAM +clock.....£24.95	Mouse Mat.....£4.95
Amiga Plus 512K RAM.....£34.95	Dust Cover.....£4.95
Amiga Plus 1 Meg.....£49.95	Super Pro Zipstick.....£14.95
Amiga/Atari Squik Mouse.....£14.95	Amiga Power Supply.....£39.95
Amiga Scart Cable.....£14.95	10 Blank Disks.....£5.95
Rom Sharer.....£19.95	

HARD DRIVES

GVP Series II HD8 with 52Mb Hard Drive
GVP Series II HD8 with 120Mb Hard Drive
GVP Series II HD8 with 240Mb Hard Drive

0 RAM	2Mb RAM	4Mb RAM	8Mb RAM
349.95	399.95	449.95	549.95
459.95	509.95	559.95	659.95
729.95	779.95	829.95	929.95



* All prices include VAT and NEXT DAY DELIVERY subject to availability
* Fixed charge for repair does not include disk drive replacement nor keyboard
* All prices subject to change without notice * We reserve the right to refuse any Amiga repair



The **AMIGA** Collection
FORMAT

No.10 RRP £50

Create any program you like...

AMOS

...it's easy and it's fun too!

Notes: this is the full AMOS latest version, but the example programs normally provided with the package are not included. Full tutorial to get you started inside.

● All Amigas ● 1Mb Required ● All Amigas ●

Get AMOS for cheap

The tutorial on this page is designed to help you get the most from the programming language AMOS. If you don't have AMOS but would like to have a go at programming your Amiga, you're in luck. Because *Amiga Format* featured the complete AMOS program on our January 1993 Coverdisk. Now you should have bought that issue, but if you didn't, we'll give you one more chance to get your hands on the truly spectacular AMOS language. Turn now to Page 186 and buy it from back issues.

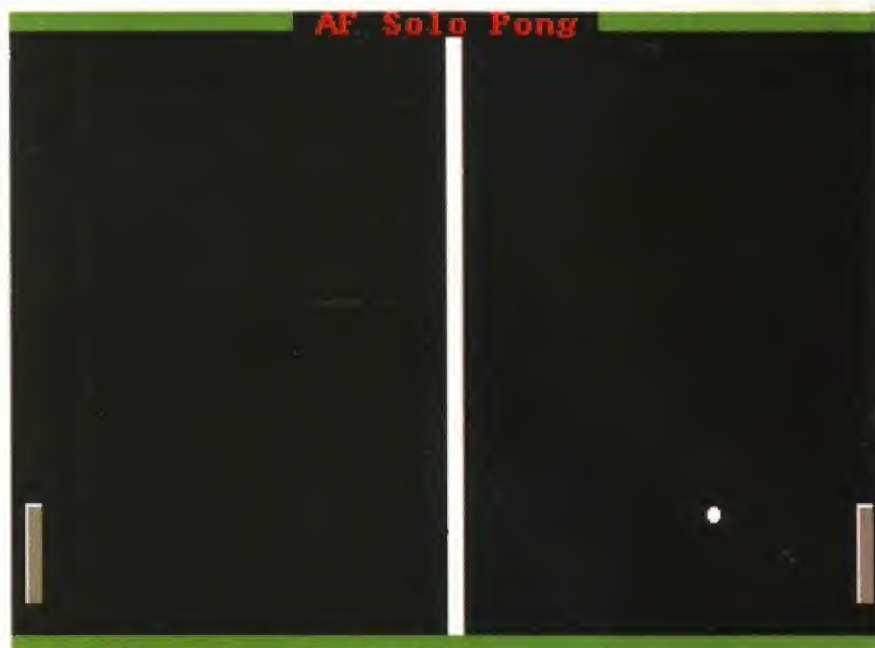

It's completely unoriginal and it's not even very good. But the important thing is, it's going to be all your own work. One interesting thing is that we're starting right at the first roots of computer gaming, here: Pong was the very first arcade game ever, invented by Nolan Bushnell in the early Seventies.

Getting the most from your AMOS Coverdisk

Last month we started off our AMOS series by giving you the full program on the Coverdisk. Now we continue with a tutorial for your first real project: our own DIY version of a classic arcade game...

SO YOU'VE BEEN waiting for four weeks now with the AMOS program loaded and nothing to run on it? Feeling a little frustrated? Oh dear, well we'd better start teaching you how to use it then, hadn't we? In this second tutorial we'll be writing a game, as that is one of the things AMOS does best. We'll make it a simple game, and to keep it even simpler we'll make it so that the program creates its own graphics and sound so you don't have to.

The game we're going to write is *Solo Pong*, a ping-pong type game where you play both players and control the paddles with the mouse. This is one of the very earliest type of computer games known to man, and one of the simplest to write using a modern programming language like AMOS.

The basic idea is that the ball bounces off of the top and bottom of the screen, but if it touches the ends, that's a goal. You stop it touching the ends by batting it away with the paddles. When you finally miss it, the game is over.

STEP BY STEP

Our program listing begins in the same way as a lot of AMOS listings, by turning off the text cursor and the mouse pointer. These just get in the way otherwise, and as our mouse will be controlling the paddles we don't need to see the pointer or the cursor. The two commands we use to do these two things are:

```
Curs Off
Hide
```

You could just as easily say:

```
Curs Off : Hide
```

putting them on the same line, but our listing tries to be clear and simple, so we don't use the colon ':' symbol to put commands on the same line unless we have to.

The next thing we do is turn on the 'double buffer' command. Double buffering is a way of ensuring sprite movement is flicker free and smooth by doing all the sprite moves on an invisible screen before they appear on the visible one. This is all done automatically by the next command:

```
Double Buffer
```

That's all you have to do. From that point on all sprite commands are done using the double buffer system, ensuring smooth and gliding movement.

Next we have to draw the sprites and grab them into the sprite bank. AMOS can do this, create sprites or movable objects by grabbing them from the screen. Equally you can draw them in a sprite editor (as was detailed in the last issue) and load a sprite bank from disk, but it's much much simpler if you can draw simple sprites using AMOS graphics commands and grab them as sprites. We only need two sprites for this program, the bat and the ball. The bat is defined like this:

```
Paper 0
Ink 7
```

```
Bar 0,0 To 5,30
```

The first command sets the paper colour for the game, colour 0 which is in this case black. The Ink command changes the colour of any drawing operations, which in this case means when we draw the bar in a moment it is colour 7 or a light grey. The Bar command draws a filled rectangle on the screen using the format:

```
Bar x1,y1 To x2,y2
```

where x1,y1 are the co-ordinates of the top left hand corner, and x2,y2 the co-ordinates of the bottom right. So in this instance we are drawing a rectangle in grey which starts at the top left hand corner of the screen (0,0) and is 30 pixels tall and 5 wide. The next line puts a white line along the left-hand side and the top to make the bat look a bit 3D, like so:

```
Ink 2
Polyline 0,30 To 0,0 To 5,0
```

The Polyline command allows you to draw lines in the following format:

```
Polyline x,y To x,y To x,y...
```

as many times as you like. This line starts at the bottom left hand corner of the Bar we just drew and in Ink colour 2 (white) goes up to 0,0, then across to the top right hand corner at 5,0.

That listing in full...

Here is the complete listing for you to type in. Just type it in exactly as it says down here, being careful to put in any spaces and punctuation marks correctly. Once you've typed the program in and saved it to disk, you can run it.

```

* ** Amiga Format Solo Pong **
* **
Curs Off
Hide
Double Buffer
Paper 0
Ink 7
Bar 0,0 To 5,30
Ink 2
Polyline 0,30 To 0,0 To 5,0
Get Sprite 1,0,0 To 6,31
Cls 0
Ink 2
Circle 5,5,2
Paint 5,5
Get Sprite 2,0,0 To 10,10
Limit Mouse X Hard(0,0),Y Hard(0,5) To
X Hard(0,0),Y Hard(0,165)
Cls 0
Pen 4
Locate ,7
Centre "Amiga Format"
Locate ,9
Centre "Presents"
Locate ,11
Centre "the very excellent"
Pen 3
Locate ,13
Centre "A F S O L O P O N G"
Locate ,24
Pen 2
Centre "<press a key>"
Wave 0 To 15
NOISE
Wait Key
'
RESTART:
Cls 0
Ink 11
Bar 0,0 To 320,5
Bar 0,194 To 320,200
Ink 2
Bar 160,0 To 165,193
Pen 4
Locate 0,0
Centre " AF Solo Pong "
X=150 : Y=100
DX=Rnd(4)+2 : DY=Rnd(2)+1
R1=Rnd(10) : If R1>5 Then DX=-DX
R2=Rnd(10) : If R2>5 Then DY=-DY

```

```

MAIN:
Add X,DX : Add Y,DY : If Y<=5 or
Y>=190 Then DY=-DY
Z1=Bob Col(1) : Z2=Bob Col(2) : If Bob
Col(4) Then DX=-DX
If X>=320 Then LOSE : Goto RESTART
If X<=-20 Then LOSE : Goto RESTART
If Z1<>0 Then DX=-DX : DX=Rnd(5)+3
If Z2<>0 Then DX=Rnd(5)+3 : DX=-DX
Y1=Y Screen(Y Mouse)
Bob 1,5,Y1,1
Bob 2,310,Y1,1
Bob 3,X,Y,2 : Wait 1
Goto MAIN
'
Procedure LOSE
Boom
Pen 3
Centre " Game Over, Man "
Locate ,24
Centre " <press a key> "
Wait Key
End Proc
'
Procedure NOISE
For L=79 To 0 Step -1
Play 96-(20*(L/2)),0
Wait 1
Next L
End Proc

```

Finally we grab the sprite image with the command:

```
Get Sprite 1,0,0 To 6,31
```

This is similar to drawing a bar, but in this case we over shoot the image by one pixel to make sure it's enclosed by the command, so rather than 0,0 to 5,30, we go from 0,0 to 6,31. The first number (in this case 1) tells us which image in the sprite bank that the graphic we just grabbed will be stored.

The image for the ball is created in very much the same way:

```

Cls 0
Ink 2
Circle 5,5,2
Paint 5,5

```

First we clear the screen with Cls 0, clear the screen will colour 0, then we select Ink 2 (white) and draw a circle using the circle command. The command follows the form:

```
Circle x,y,r
```

Where x,y is the centre of the circle to be drawn (in this case set to co-ordinates 5,5) and r is the radius, (in this case 2). The circle is hollow when we draw it, so to make it more interesting we fill it with colour using the Paint command. We centre the paint command's attention to the centre of the circle and voila. One filled circle. Then we grab it with the command:

```
Get Sprite 2,0,0 To 10,10
```

This grabs the image of the circle into the sprite bank as image 2.

The next line is a little bit incomprehensible, and for the moment you'll have to take this one on trust. We are limiting the mouse movements to ensure it doesn't stray too far up or down. The fine detail on this command can wait for another issue, but for the moment just bang this in:

```
Limit Mouse X Hard(0,0),Y Hard(0,5) To
X Hard(0,0),Y Hard(0,165)
```

Now we're back on familiar territory. The title screen is made by clearing the screen and printing up some words. The Locate command positions the by now invisible cursor at a screen location ready for printing text on the screen. It's not measured in pixels like line drawing or other graphics. It's measured in text characters. So the visible screen in this game (it's only 200 lines tall for our NTSC based overseas readers to enjoy) is 39 wide by 24 characters tall. So the following code:

```

Cls 0
Pen 4
Locate ,7
Centre "Amiga Format"
Locate ,9
Centre "Presents"
Locate ,11
Centre "the very excellent"
Pen 3
Locate ,13
Centre "A F S O L O P O N G"
Locate ,24
Pen 2
Centre "<press a key>"

```

speaks for itself. The space before the comma in the

Locate commands should contain a zero, but as in all AMOS commands you can leave figures out and the program simply assumes you mean nought. Pen sets text colour, in the same way Ink sets graphics colour. Pen 4 is red, Pen 2 is white, and Pen 3 is a special flashing colour, giving you that nice pulsing effect on the name of the game. The Centre command is like Print, it prints text on the screen. Check out the difference in effect between these two lines in Direct Mode:

```
Centre "Centre Amiga Format"
Print "Print Amiga Format"
```

The Centred text is in the middle of the screen and the Printed text is clinging to the left hand side of the screen.

Next we make a noise, this is created with a Procedure called NOISE. NOISE is not an AMOS keyword but a Procedure, special subroutine which is created by you and activated when we use the word NOISE. The commands contained in the Procedure NOISE is defined at the end of the program. It doesn't matter where you put the Proc definition, as long as it is in the program somewhere. Procs will not be activated unless called with their title. The Wave command is called:

```
Wave 0 To 15
NOISE
Wait Key
```

followed by the NOISE title word to run the small sub-program which actually makes the noise. The Wait Key command waits until a key is pressed on the keyboard before the program moves on. We'll be going into greater depth about sound and music in a later issue of the tutorials.



Yes, it may not look terribly exciting, but our own arcade game even has its own load screen. Before too long, we'll show you how to get something an awful lot better-looking by including Deluxe Paint pictures in your programs.

Next we need to set up the start position of the program, so that each time you fail to keep the ball in play the game will reset to this setup position. To return to the right spot in the program, we use a "label", and the name of the label in this case is RESTART. We make a word a label by adding a colon to it like so:

RESTART:

This is like a bookmark in the program, so at any point we can say:

Goto RESTART

and the program will snap back to this part of the listing. What follows the RESTART label is the commands for drawing the playing area. So we clear the screen and draw bars on the screen for the edges of the play area, the "net" in the middle (which is purely cosmetic in this case) and the words "AF Solo Pong" at the top of the screen. Notice the spaces either side of the words to leave a gap either side of the lettering when it overwrites the bar. (Try leaving them out and notice the difference.)

Next we must initialise the variables, like X,Y the position of the ball, and DX,DY the vectors telling the ball which direction to go in. We just do this like this:

```
X=150 : Y=100
DX=Rnd(4)+2 : DY=Rnd(2)+1
R1=Rnd(10) : If R1>5 Then DX=-DX
R2=Rnd(10) : If R2>5 Then DY=-DY
```

The R1 and R2 calculations are simply a random number generated to literally 'get the ball rolling'. If the random number is less than 5 then either or both of the DX and DY vectors are negative. If a vector is negative then the move is either left or up, if it's positive then it's right or down.

Now we have the main part of the program, which you can see we have labelled MAIN. This is the main program loop, which adds the vectors to the current position of the ball. If Y is equal to 5 or 190 then the ball flips direction:

```
MAIN:
Add X,DX : Add Y,DY : If Y<=5 or Y>=190
Then DY=-DY
```

This means that if the ball goes higher than 5 pixels from the top or lower than 190 pixels, it will be automatically bounced away, creating the bouncing effect. The ball sprite is not being bounced off of the bar we drew earlier, it's just a special effect which makes it look as though it is. Next we check the various objects on the screen to see if any of them have collided.

```
Z1=Bob Col(1) : Z2=Bob Col(2) : If Bob
Col(4) Then DX=-DX
```

This line goes hand in hand with the lines:

```
If Z1<>0 Then DX=-DX : DX=Rnd(5)+3
If Z2<>0 Then DX=Rnd(5)+3 : DX=-DX
```

which come along later in the listing. These test the three sprites or bobs (we'll be going into the difference between sprites and bobs later in the series) to see if they have hit any of the other objects on screen. Obviously the two bats can't hit each other, so mainly it'll be testing for the ball hitting one of the bats.

When it does hit the bat rather than the end zone, the ball will then bounce off, like it does from the top and bottom of the screen, by flipping the vector from positive to negative or vice versa. So if it's going towards the bat in a negative direction from right to left, and then it hits the bat, the direction will be changed so the ball is going in a positive direction, left to right. A little random spin is put on the ball too at this point using the Rnd(x) command. This ensures that when the ball hits the bats the angle and speed are never predictable.

```
If X>=320 Then LOSE : Goto RESTART
If X<=-20 Then LOSE : Goto RESTART
```

These lines test for the ball hitting the end zones at the left and right of the play area. If the X co-ordinate is less than -20 or more than 320 then the ball has made it out of play and the game is at an end. The LOSE Proc

is activated which runs the following little program, defined at the end of the listing:

```
Boom
Pen 3
Centre " Game Over, Man "
Locate ,24
Centre " <press a key> "
Wait Key
```

Boom makes a slow explosion, Pen 3 sets the flashing colour and then Locate and Centre combine to print the end game words at the top and bottom of the screen. The Wait Key command waits until a key has been pressed, then returns us back to the point the LOSE Proc was called. In both cases, the program is then sent off to the RESTART label, starting the game all over again.

The last part of the game main loop deals with the actual movement of the bobs or sprites. Y1 is told to be equal to the Y position of the mouse. The reason for couching the command in so many brackets the difference between hardware co-ordinates and screen co-ordinates. Unless you convert hardware co-ordinates to screen co-ordinates, when reading the mouse for example, you're pointer will be way off the mark.

After that it's all plain sailing, with the Y1 figure being passed to the Bob command, which updates the position of the bobs every time it goes around the main program loop. Bob 1 is paddle 1, bob 2 is paddle 2 and bob 3 is the ball.

```
Bob 1,5,Y1,1
Bob 2,310,Y1,1
Bob 3,X,Y,2 : Wait 1
```

The Wait 1 on the end of the bob commands is a little pause to slow the ball down a little. Take it out and the ball moves faster than the eye can follow.

Lastly the main loop is closed by the words:

```
Goto MAIN
```

Which sends us back to the MAIN label.

All that's left in the listing are the Procedure definitions, including the NOISE Procedure:

```
Procedure NOISE
For L=79 To 0 Step -1
Play 96-(20+(L/2)),0
Wait 1
Next L
End Proc
```

This makes the noise which you hear when the program starts, and it works by using the Amiga's internal sound chip, rather than samples as is normally the case. The Play command is used in a loop, which takes the variable L down in size from 79 to 0 and uses it in the calculation to produce the noise. We'll go into depth about this when we talk about sound, but play about with it to see what effect it has if you don't use the Wave command, or alter any numbers in the formula.

AND SO...

Now you have a game which is fun to play, but doesn't really go anywhere. Next month we'll be augmenting this program, making it bigger, better and more complex, based on the principles learned in this basic design. We'll add a two-player mode, more graphics and more sound to make this a playable and amusing diversion. See you then, AMOS type folks.





At last a range of Joysticks with looks and performance that comes straight from the Arcade. With prices starting from as little as £13.99, they are seductively transparent to show their internal workings rippling like the muscles of an Iron-pumper.

SV135 MEGASTAR JUNIOR ▷

- Steel Shaft
- 7 Heavy-duty Microswitches
- Auto-Fire
- Left/Right Hand Switches

£18.99 inc. VAT



▷ **SV127 TOPSTAR**

- Six Heavy-duty Switches
- Auto-Fire
- Pistol-Grip

£22.99 inc. VAT



▷ **SV131 SUPERSTAR**

- Steel Shaft
- Six Heavy-duty Microswitches
- Auto-Fire

£13.99 inc. VAT



Just what your AMIGA wanted!

Logic 3

LOGIC 3 products offer three things — style, quality and performance. There's that certain look, that certain feel that make LOGIC 3 products special. LOGIC 3 — 'Putting style into computing'.

▷ **LG737 SIGMA-RAY**

- Sigma-Ray table-top Joystick
- Six microswitches (closed type)
- Additional base fire buttons
- Rapid-fire function

£12.99 inc. VAT



▷ **LG 203 MANTA-RAY**

- Hand-held Joystick
- Six microswitches (closed type)
- Rapid-fire function

£11.99 inc. VAT



▷ **LG2RG SPEEDMOUSE**

- for Amiga/Atari Computers
- ultra-sensitive buttons
- Smooth and accurate movement
- Comfortable to use

£16.99 inc. VAT



THE Q&T FOOT-PEDAL

▷ **ENHANCE YOUR VIDEO GAMES**

... Sometimes just using a Joystick is not enough to beat today's generation of computer games. The Foot Pedal Controller works in conjunction with a Joystick. By aligning any three of the Joystick functions to synchronise with the Foot Pedals it enhances any multi-functional game that includes flying, driving or playing sports ... games-playing will never be the same.

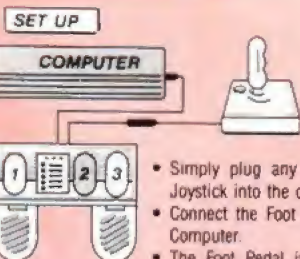

SV129 Foot Pedal Controller

£24.99 inc. VAT

- Simply plug any standard 9-Pin Joystick into the cable supplied.
- Connect the Foot Pedal into your Computer.
- The Foot Pedal is now ready to use.

Advanced GRAVIS

Simply the best ... GRAVIS products are made in Canada to the highest standards of Joystick Design and Engineering. They are comfortable to use and are built to last. In fact, you will probably need a new AMIGA before the GRAVIS gives up!

Clear

£32.99 inc. VAT

Black

£29.99 inc. VAT

▷ **GRAVIS SWITCH JOYSTICK**

- Eight position Tension Control
- Microswitch Fire-Buttons
- Independent Function Fire-Buttons
- Foam Padded Grip
- Black or clear versions available



▷ **GAMES PAD for AMIGA**

- 4 quick response buttons
- Select Single-Shot and/or Turbo-Fire
- Removable Joystick Handle
- 6 foot cable
- Left/Right Handed Button
- Controller Layout

Games Pad for Amiga

£19.99 inc. VAT



Datalux

▷ **DESIGNER MEDIA STORAGE**

Expertly designed, these boxes are not only practical and user-friendly, but are tough enough to provide years of trouble free service.

Just look at the features:

- Robust High Impact Base
- Removable Lid
- Incorporated Integral Lock
- Organisier Dividers
- Transparent Top
- Rubber Feet
- High Capacity
- Space Saving Flat Pack
- Comes in 3 parts for quick Snap Assembly
- van.3 holds up to 80 3.5" Diskettes
- van.5 holds up to 80 5.25" Diskettes

SV 510 3 1/2" version

£8.99 inc. VAT

SV 500 5 1/4" version

£8.99 inc. VAT



Give your AMIGA what it wants!

AVAILABLE FROM MOST COMPUTER STOCKISTS



OR TELEPHONE: 081 902 2211



SPECTRAVIDEO, UNIT 27 NORTHFIELD INDUSTRIAL ESTATE, BERESFORD AVENUE, WEMBLEY, MIDDLESEX HA0 1NU, ENGLAND
 TELEPHONE: 081 900 0024 • FACSIMILE: 081 903 6625 • HOTLINE 081 902 2211

Amberstar

OUT NOW FOR
PC, AMIGA
AND ATARI ST!



Screenplay

It's that just-after-Christmas time of year: a time when all the really big-name games, the ones that everyone hoped would be here in time for Christmas, finally make it. So forward, troops, and take a look at an amazing range of new releases.

FIGHTING FOR YOUR RIGHTS!

Each month, **Amiga Format** brings you the very best in game reviews. We're committed to telling you exactly what's wrong and right with each game, with no holds barred. Not long ago we were all punters too, and every one of us has had a nasty experience with a duff game at some time or other. We don't want that to happen to you, so each game we receive has a whole host of tests to pass before it gets our ultimate accolade – the **Amiga Format Gold**.

Does it play well? Are the graphics worthy of our Amiga super-machine? Is the sound up to scratch? Does it work on ALL Amigas? Will it install to a hard drive? These are just a few of the challenges a good game could rise to, but still the crap games keep a-coming. What's worse is that we often see tired old garbage rated highly in other mags. Have they no shame? Don't they care about you, the poor innocent punter who shells out hard-earned cash on these white elephants?

We don't believe anyone else in the Amiga market is qualified to bring you the low-down on the vast range of new titles. Our team is made up of the some of the hardest-to-please reviewers you could ever find. They've seen it all before, and they've often been on the receiving end – and now it's their turn to answer back with the truth. Trust us – we're on no-one's side but yours!

FIGHT THE GOOD FIGHT FOR ALL YOU'RE WORTH



Streetfighter 2

Possibly – no, in actual fact, positively, definitely and absolutely – the most-hyped, most-anticipated and most street-cred game of the year. It was an enormous hit in the arcades which has left almost everyone in the country drooling in expectation of the imminent arrival of a version for the world's top home computer. But after all, it's just a beat-em-up, isn't it? So can it possibly achieve a decent score? Do we have a top-notch conversion on our hands, or are we going to be sneered at by Super Nintendo owners? Head for... **Page 82**

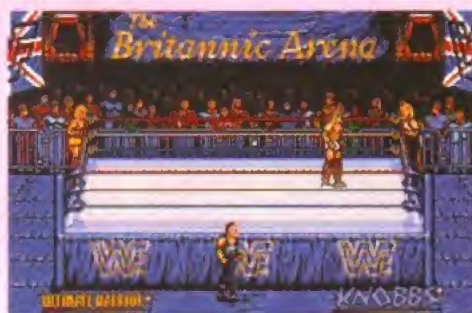

WWF European Rampage Tour

Last year, there was no hotter property than the wrestlers of the World Wrestling Federation. The videos sold like hot cakes, there were heaps of small plastic figures to be bought and as for the game... well, the game came out of nowhere to be Christmas Number One. But it was a poor game. This year the craze is still going strong: but will we get the game we deserve? **Page 64**



Premier Manager

A decent football management game? Surely it's a contradiction in terms. A footie sim that's lively and exciting as well as being in-depth, detailed and accurate? Probably quite impossible. That's what we thought, and that's where the matter rested: until one day Gremlin popped in to visit and brought with them the answer to a dedicated football fan's prayers. **Page 58**



Indiana Jones – Fate of Atlantis

We all know LucasArts can produce a mean graphic adventure game: after all, *Monkey Islands 1* and *2* still rate amongst the best games ever created. But it all gets a bit sticky when it comes down to film licences. Could the fact that they've made the plot up themselves help this one along? Is it destined to be a classic? We'll see! **Page 72**



Nick Faldo's Championship Golf

Golf games come and golf games go and, surprisingly, many of them are very, very good indeed. Even if you aren't remotely interested in the real thing, there's something about a golf game that really works. Now *PGA Tour Golf* plays a blinder while *Links* looks stunning – but is there a place for a game that does both? **Page 90**

THE REVIEWERS

Everyone's got their own favourite type of game, and at **AF**, we put that to good use. We look at each reviewer's special skills (and predilections) and turn them to your advantage. Our chosen experts know what to look for in their favourite genres, and they're much more likely to get offended if they don't find anything worthwhile. Here's what our team is up to this month...

NEIL JACKSON

AF's warlike Screenplay Ed is just the man to get conscripted into an all-out war. Find out if he knows how to handle his weapons in *HistoryLine*.

ANDY NUTTALL

Andy's an adventure-freak, and this month he tests Lucasfilm's stunning new *Indiana Jones* epic. But is it better than *Monkey Island 2*?

JAMES LEACH

A bit of a heavyweight brawler, James is the ideal candidate to take on *Streetfighter 2*, and win. Find out how badly bruised he was.

TIM SMITH

He's football crazy, but never backs a losing side. Tim joins the Rovers and attempts to take them to the top in Gremlin's new *Premier Manager*.

MARCUS DYSON

Nope, he's not a trainspotter, but he loves to spend his time hanging around on platforms. And he can do a few neat tricks with *Tomatoes*, too.

CHRIS BUXTON

Small but perfectly formed, Chris is a total hard-man. We put him to the test on *Lethal Weapon*, and watched Mel Gibson run away crying.

Football management games have almost been as unpopular as footy managers are in real life, but that's about to change...

Earlier on in 1992 there was a conversation in the *Amiga Format* office that went something like this:

"Never, no chance, no way will anyone bring out a decent football management sim!"

"Er... who cares. Get on with some work."

"But, there are good flight and driving sims, there's even a good submarine sim, but there isn't a good footy management sim!"

"So what?"

"There are millions of people all over the country who know they can do a better job than their team's manager. So why is there no decent footy management sim yet, eh?"

"I don't care and it's deadline!"

"God, you've got about as much perception as Graham Taylor, you have."

"Watch it!"



So many options, and only a 500-game season to sort them all out. Well not really 500 games, but once you get into the character of a manager, you have to start the pathetic excuse-making too.

Premier Manager

which usually takes two months. This is an area in which you'll be in for a bit of a shock to the bank balance. Working your way from a single safety star rating to two stars costs £50,000. Moving from two to three stars leaps to an awe-inspiring £250,000.

But you're not here for the dosh. Oh no, you're here for the thrill of the game (or the jewellery if your management technique comes from the Allison/Atkinson school or the Lyall/Keegan).

There are two areas in which the game excels. Team selection and training; you don't get lumbered with players who are simply

midfielders, defenders and so on. If this was the case in real football, there would be no Rijkaards, no Platinis and no Pearcees – players who can play all over the pitch.

You are given players who are graded on the way they handle (what would Maradona get?), tackle, pass and shoot. This enables you to create players who can specialise, while being able to play elsewhere – you could get attacking left-backs, keepers who (at a pinch) can hold their own in defence and so on.

You improve players by training them, or by getting your head coach to do it for you. This is where a great touch comes in, you can

And so it went on

Then comes *Premier Manager*. It looks great, it doesn't crash when you get to a decent level of attainment, and it includes aspects of 'The Game' other sims of its genre pass by.

Premier Manager puts you in the shoes of the most-hated and most-loved figures in football. Defenders might blunder, strikers might fluff open goals, midfielders might play hospital passes, but only managers can pull Lineker off with 20 minutes to go to howls of derision. But managers have to start somewhere, and here you start in the GM Vauxhall Conference.

You begin with a budget of over £200,000 – a sum dreamt of by real-life GMVC clubs. But this is not to be blown on the first decent libero you see on the transfer market. You have to improve the stadium's facilities and safety, plus you have to employ backroom staff, coaches, scouts and so on.

Once the 'money out' is sorted you have to turn to the 'money in'. In this case there is stadium advertising to work through. You have 48 ad placings, and making the right deals might keep you clear of your £300,000 overdraft limit.

You will probably only check on the upkeep of ads every four or so 'weeks', and once you've set up work on ground improvements, you have to wait for their completion



The match in progress. As you can see, the graphics leave something to be desired: there they are, top right.

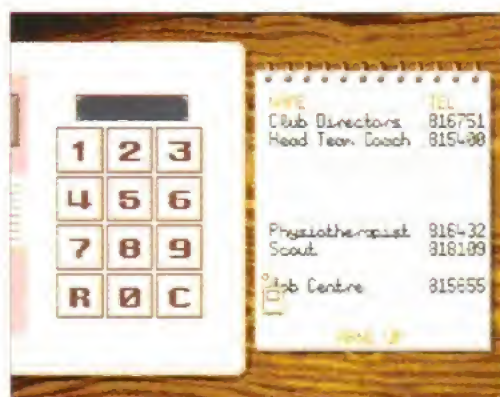

Your staff need you, and this neat little telephone thingie makes it so much easier to shout at them.



Two minutes away from the end of the first half, and Bath City are 2-0 down. Great come-backs ahoy?

GROUND IMPROVEMENTS

DAVE PAGET
TWERTON PARK
BATH CITY
£182321

INSTALLING
A SMALL
SCOREBOARD
WILL COST
£5000

STANDING CAPACITY: 812/9570
SEATING CAPACITY: 86/730
SAFETY RATING: ★
GROUND FACILITIES: BASIC
SUPPORTERS CLUB: SMALL
UNDERSOIL HEATING: NONE
FLOODLIGHTS: NONE
SCOREBOARD: NONE
▶ LEAVE GROUND IMPROVEMENTS ◀

ADVERTISING BOARDS

BOARD 42 (0)

BOARD 43 (0)



Money, money, money – you have to get it from somewhere. In this case it's time to visit the Twerton Park advertising hoardings. If you get lucky, you might even have Amiga Format up there.

coach and train the players individually. You don't have to look on each of them as merely parts of a faceless section of the team. As is essential with any simulation, this adds those elements of personality to the game.

But of course, as a GMVC manager, you haven't exactly been given AC Milan's squad to muck around with. And no matter how much training, they will never be able to beat Arsenal with its squad of 'Ultimate' players. 'Ultimate' is one of the ratings given to players on the transfer market. Other ratings are Fair, Good, V Good and World Class.

To buy players you can use a scout (£90 a week, cheers Guv!) but this limits you to poaching players from your division and division(s) below you. Or you can go on to the transfer market where you have to bid against other managers.

Premier league?

You will normally find Conference and 'part-time' players will go for a song – sing £25K and up when you're winning – but as soon as you leap into the Second Division (or Third, if you forget the BSkyB and Premier League rubbish) you find yourself staring in the teeth of £600,000 bids. A little unrealistic really when my local Div One club were able to pick up two QPR players from the Premier League for £370,000 the pair in real life. But I guess that this is all about gameplay.

So once you've chosen your team, dabbled in the transfer market and worked out the finances, it's time for a game. With *PM* you get to see what your opposition is like in terms of strengths and style of play. Playing styles range from the dastardly 'Long Ball' or 'Route 1' via Attacking, Defending and Passing.

You can also alter your team's formation, so balancing your formation and playing style against the opposition's can take time and thought. But then it's time for you to get on

the field of play and suffer as your boys forget everything you've told them. It is here I would like to see a 'team talk' module. I would also like to see better sound than white noise (talk to the Sensibles, Gremlin!) and far better in-game graphics.

“An excellent addition to Amiga games”

No matter how much you think that management sims are for footy-addicted trainspotters, the game is still the thing and not the number crunching. Better graphics could (and with the A1200 replace 'could' with 'should') be included in a game that is supposed to simulate high-adrenaline action. What we get are some tame vignettes of players in shirts (that you haven't chosen) where the opposition seems to be playing the same colour, tapping balls around in close up in the top tenth of the screen. This is why it falls short of a *Format* Gold.

One other grumble: when you think you are financially stable, you get hit for absurd fines (bringing the game into disrepute – why? Food hygiene! Faulty floodlights!) That apart, *Premier Manager* is an excellent addition to the pantheon of Amiga games. Nicely worked, well thought out, and playable on an A500!

Tim 'Gashead' Smith ☺

Premier Manager Gremlin ■ £29.99

- Great training and team selection.
- Stupid fines which you can do absolutely nothing about.
- Transfer fees are unrealistic, but it does have a good feel for the game.
- In-game graphics and sound could be improved somewhat.

Verdict: **87%**

FOOTBALL TACTICIAN 2

We set the standards We break the records.

Widely accepted as the most accurate football simulation available, **FOOTBALL TACTICIAN 2** has taken the strategy scene by storm. Record after record is being broken:

- * **Biggest ever multi-user system:** up to 46 users! (who said four was the limit?) Now with new rating system reflecting managers' ability and achievements.
- * **First ever fully interactive management game:** intervene at any time during a match to change tactics, make substitutions, adjust formation or mark players.
- * **Most accurate player definition:** 30 parameters including real ages, aptitudes, skills, caps, playing positions, fitness, morale and market valuation.
- * **Most accurate teams:** 20-player squads updated EVERY WEEK! If your game still lists Des Walker at Forest or Eric Cantona at Leeds, then it isn't *Football Tactician!*
- * **Largest results database:** 21290 match results and league positions going back 20 seasons all instantly retrievable. All of which may be printed out.
- * **Largest ever recording options:** 36 matches always recorded IN FULL for instant full-scale replay, plus selected REAL matches that actually took place in real life.
- * **First ever referee involvement:** true to life behaviour. Beware of adopting 'rough tactics' when Jim Parker is in charge! The message is clear: know your refs.
- * **Fastest ever setting-up time:** initial start-up in less than two seconds, thanks to 900K of super-fast machine code. Smoothness of action is FT2's hallmark.
- * **Most accurate editor:** built-in intuitive editor capable of entering new players and fine-tuning all parameters. Essential for the serious user.
- * **First ever simulation capable of replaying REAL matches** (ex: the Leeds-Rangers clash in the European Cup)
- * **First ever Scottish only simulation:** FT2 Scotland now available separately.

FOOTBALL TACTICIAN is the first ever management game that includes strategy as an integral part of a successful campaign. Team selection, needless to say, remains a critical element. But the BIG innovation is your involvement during the match: for the first time ever, you will, as a manager, be able to alter your strategy: choose a defensive or offensive system, mark certain opponents, drop back some of your players if the pressure is tough, decide exactly when substitutions should be made, play the off-side trap, go for quick counters, etc... With full on-screen commentary and minute-by-minute feed-back, you're as involved in the match as any of your players! You will soon realise that this is no ordinary soccer manager. THIS is the REAL THING. You're in charge. You manage your side before and during the match. Nothing is left to chance. Can you rise to the challenge? Try **FOOTBALL TACTICIAN** and prepare yourself for the ultimate football experience.

New features include:

- * **FA Premier League and Division One** permanently in memory with full interaction, promotions, transfers, play-offs, local and European Cups.
- * **900 players accurately and meticulously named,** plus accurate European players
- * **Unique database-type search facility plus comprehensive data link giving access to additional, accurate, historical information on selected players.** This feature may be further enhanced by the user himself.
- * **Intelligent behaviour of computer sides** capable of changing tactics to respond to situation on the field or making substitutions based on fitness and fatigue.
- * **Three levels of commentary,** from highlights only to ball by ball reporting. Plus mid-week transfer and fitness news.
- * **Friendlies, top scorers charts, precise transfer markets, club history, financial position and much much more!**

No known football game is more accurate! FT2 is updated weekly: transfers, bids, injuries are recorded as they happen, not a year later. Users ALWAYS receive the very latest version.



And now FT2 SCOTLAND! With the Premier AND First Divisions and of course all the unique characteristics and playability of the original *Football Tactician 2*.

Please rush 1 copy of
FOOTBALL TACTICIAN 2 (one meg required) **£22.95**
FOOTBALL TACTICIAN 2 (Scotland) (one meg) **£22.95**
 Also available
FOOTBALL TACTICIAN 1 (half-meg machines) **£16.95**
 coming soon **FT2 Italia Serie A**
 I own an AMIGA A500 A600 A1200 ATARI ST/STE

Name
Address

I enclose cheque for _____ My Visa number is _____
 Visa or Access orders same-day dispatch Overseas please add £1 p&p

TALKING BIRDS 0702 523607

5 Minster Close Rayleigh Essex SS6 8SF

Award winning innovative products from

Scanners

"If your in the market for a hand scanner then forget the rest and get Powerscan"

Amiga Format July 1992

Power Scanner v3.0



- 100-400 DPI scanning resolutions
- 64 greyscales
- Thru'port for printer
- Award winning editing, image manipulation & scanning software

Power Scanner v3.0£115
Power Scanner Colour£239

Epson GT-6500



- 600 DPI Colour flatbed scanner
- 24-bit colour
- Software included

GT-6500 inc. Powerscan v3.0£799
GT-6500 inc. ASDG Software.....£899
Transparency Adaptor Unit.....£499
Document Feeder.....£399

Epson GT-8000

- 800 DPI colour flatbed scanner
- 24-bit colour
- Software included

Epson GT-8000£1199

Upgrade Offers

If you consider your scanner system to be inferior to the Power Scanner, we will happily upgrade your software and interface. (Power Scanner is compatible with most scanning heads)

v3.0 Upgrade (inc. interface).....£49.95
v3.0 Software upgrade for PowerScanner users (send SAE)£15

The Amiga can only display 16 greyscales

Floppy Drives

"This drive contains more gadgets than Batman's utility belt"

Amiga Computing Feb1992

PC880B Power Drive



- Award winning drive manufactured by Power Computing
- Super slim design
- Anti-click (Cures that annoying click)
- Virus blocker (Prevents viruses)
- Built-in backup hardware

PC880B with Blitz Amiga£60
PC880B with Blitz & XCopy£75
PC880B (Cyclone compatible)*£65
PC880B in black case£65

*This drive is only available to registered owners of XCopy Professional. You must provide proof of purchase of XCopy Professional

Power Drives

PC880E Economy drive£49.95
PC881 A500 Internal drive£40.00
PC882 A2000 Internal drive£45.00

Dual Drive

- Two high quality disk drives built into one compact unit
- Same features as PC880B

Dual drive£125

Blitz Amiga

- Backup disks at lightning speeds
- Stops all external drives from clicking
- Contains anti-virus from being written into the bootblocker

Blitz Amiga£20

1.44MB Power Drive

- 1.44MB disk drive
- High density floppy disk drive

1.44MB Power Drive£POA

PCMCIA Memory

- Ultra slim memory cards
- 1MB & 2MB
- For A600/A1200

1MB Memory card£POA
2MB Memory card£POA

RAM Expansions

A600 Memory Cards



1MB RAM with clock£39.95
1MB RAM without clock£34.95

PC501+ RAM Card

Our RAM board is designed especially for the A500+ computer and comes with 1MB of RAM on board to expand your memory to 2MB of chip RAM. Plug-in and go operation (Fits into the trapdoor)

PC501+ RAM card£35.95

8MB for any A500

- Plugs into side slot, fully auto config, full thru'port. Expand 2MB-8MB

2MB £109 4MB £169 8MB £289
1 x 4ZIP chips£14.95

2MB for any A500

- Economy 2MB RAM externally cased
- 16-chip (1 x 1 DIP)
- No thru'port

2MB RAM£79

1.5MB RAM Board

- Fully supports 1MB of chip RAM
 - Fully compatible with Fatter Agnus
- (Kickstart 1.3 and above, not compatible with A500+)
(Your Amiga needs to be opened, this may effect your warranty)

1.5MB RAM board£75

1MB with Thru'port

- Expand your A500's memory up to a total of 2MB without disposing of your existing 512K upgrade
- Works with 1MB of Chip RAM

(512K RAM must be 4 chip type or not exceeding 9cm in length)
(Your Amiga needs to be opened, this may effect your Warranty)

1MB with thru'port£45

A500 RAM Card

- 512K RAM expansion with clock & free software (A500+ compatible)

512K RAM (4 chip)£29
512K RAM without clock£24
512K RAM (16 chip) with clock£24
512K RAM (16 chip) without clock£19

Auto ROM Sharer



- Kick-off is the latest Amiga add-on from Power
- One of the most advanced kickstart ROM sharers available
- A clever design on a small reliable board
- Fits A500, A500+, A1500
- Kickstart ROM can be selected from the keyboard
- No messing about with switches
- No "CIA adaptor" or other trailing wires
- Jumper to select which ROM boots on switches
- Compatible with old Amiga board revisions
- Simple internal fitting*

* Kick-off requires the lid to be removed from the Amiga. This may invalidate your warranty.

ROM Share	£17.95
ROM Share inc. kickstart v2.04	£55
ROM Share inc. kickstart v1.3	£39
ROM Share for A600	£29

Kickstart v2.04

2.04 Kickstart (chip only)	£39.95
2.04 Kickstart ROM, workbench software, install disk 2.04, font disk & extras	£79.95
2.04 kit with ROM sharer	£99

Video Backup System

- Use VCR as a backup storage device
- Blank video tape is all that is required
- 200 Amiga floppy disks will fit on a 4 hour tape
- Can be used for hard disk backup
- There is room for 175MB of data
- Backup an Amiga diskette in 1 minute
- Restore even to an unformatted disk
- Hard disk backup, software allows you to specify which files and directories to be stored
- Low cost storage, 2 pence per MB
- Menu driven software
- Allows you to watch TV on a 1084s monitor
- Very high reliability
- Log files, contain title and counter position of every backup
- Video connection check, ensures fool proof operation
- Effective error-correction scheme
- Easy to understand manual

Video Backup System **£59.95**

A500 Hard Drives

GVP A530 Turbo HD



- 40MHz 68030EC accelerator
- Optional 68882 maths co-processor
- Up to 8MB 32-bit FASTRAM on-board
- Award winning

42QMB HD 0MB RAM	£549
80QMB HD 0MB RAM	£649
240MB HD 0MB RAM	£1054
68882 Upgrade kit	£224

GVP Series 2 HD

- Up to 8MB FASTRAM on board

40QMB 0MB	£329	80QMB 0MB	£399
40QMB 2MB	£379	80QMB 2MB	£449
40QMB 4MB	£440	80QMB 4MB	£499
40QMB 8MB	£509	80QMB 8MB	£549

ICD Novia Internal HD

- Fits inside your Amiga 500
- Comes complete, just plug-in and go

Novia 40I 40MB HD	£279
Novia 80I 80MB HD	£349

ICD Flicker Fixer

Flicker Free Video 2

- Stop that annoying flicker
- Fits internally in the A500
- Multi-sync monitor required

Flicker Free Video 2	£199
NEC 4FG Multi-sync monitor	£549

Chips

4MB x 8SIMM	£90
1MB x 8SIMM	£25
256K x 4DRAM	£4.00
1MB x 1DRAM	£3.95
1 x 4 ZIP	£14.95
1 x 4 DIP	£19.95
A3000 Static column RAM	£19.95
SIMM 32 x 1MB-60	£65
SIM 32 x 4MB-60	£243

(These chips cover most memory & hard drives i.e. GVP, Supra, Commodore)

The Power BBS

- Free technical and buying advice
- Thousands of free files available for download
- Great discounts on all Power products
- On-line ordering to ensure speed of delivery
- Conferencing with top computer magazines
- Regular bulletins with latest product information

The Power House BBS

0 2 3 4 8 4 1 5 0 3

**24 hours
All speeds up to 16.8K**

Commodore CDTV



- CDTV player
 - Welcome disk + caddy
 - Keyboard
 - Floppy disk drive (black)
 - Wired mouse
 - Workbench 1.3 and manuals
 - Infrared remote control
- | | |
|---------------------------------|-------------|
| CDTV multi-media pack | £599 |
| A570 CD-ROM drive for A500..... | £349 |

CDTV Software

A Bun for Barney.....	£29.99
Barney Bear goes camping	£29.99
Battlechess	£39.99
Case of the Cautious Condor	£34.99
CD Remix v2	£34.99
Fred Fish CDPD Collection	£19.95
Fun School 3 (under 5's)	£24.99
Fun School (5-7yrs)	£24.99
Fun School (Over 7yrs)	£24.99
Guinness CDTV Disc of Records	£34.99
Illustrated Holy Bible	£29.99
Music Maker	£34.99
NASA Heroic Age of Space	£19.99
Power Pinball	£29.99
Sim City	£29.99
Trivial Pursuit	£49.99
World Vista Atlas	£54.99
Xenon 2 Megablast	£29.99

More titles available

Award Winning Manufacturers

Power products come with full technical support

"The Power Mouse is my pick of the month"
CU Amiga

PC880B "Well worth spending your hard earned pennies on, an excellent buy"
Amiga Computing

Dual Drive "Now this is a bit special"
Amiga Computing

Power Scanner
Amiga Shopper Best Buy

Power Scanner
Amiga Format Gold

"Power Scan is quite simply the best Amiga hand scanner available"
Amiga Format

Credit Card Hotline

0234 843388
10 LINES

Fax 0234 840234
Technical 0234 841882

VAT included

(UK mainland only)
48Hr delivery £2.50
24Hr delivery £4.50
Parcel post delivery £1
(Not for orders over £50)

Power Computing Ltd
Unit 8 Railton Road
Woburn Road Ind. Estate
Kempston Bedford
MK42 7PN



Established 1985

Specifications & prices subject to change with out notice
All trademarks acknowledged



IS THIS

**AMIGA
POWER**

WHICH WE SEE BEFORE US?



If you're looking for an Amiga magazine which offers games-only coverage, then there're no two ways about it. **AMIGA POWER** is the dedicated Amiga games magazine for the dedicated Amiga games player.

Now officially
Britain's biggest selling
Amiga games magazine

60,184
readers and growing!



MADNESS!

SIMPSONS PACKED FEBRUARY ISSUE ON SALE NOW, FEATURING...

- A massive review of the long-awaited *Krusty's Fun House*, and in-depth preview of *Bart Vs The World*.
- *The Chaos Engine* - can this really be the Bitmap Brothers' finest?
- The A to Z of Arcade Conversions - the definitive AP guide to every coin-op game ever released on the Amiga.
- A look at Tony Crowther's latest epic - *Captive 2*. Is this the new state of the art in role-playing games?
- Page after page of reviews, including *Nick Faldo's Golf*, *History Line*, *Harrier*, *Dragon's Lair III* and *WWF European Rampage*. We separate the wheat from the chaff, praising the greats and pointing the finger at the real stinkers.
- Plus! The shocking truth about clones, tributes, and games with rather suspicious origins. Are we being ripped off, or is it okay for a game to be heavily influenced by somebody else's ideas?

**AMIGA
POWER**

Attitude on the second Thursday of every month.



AMIGA POWER POLICY OF TRUTH

- We won't review unfinished games just to claim an exclusive.
- We don't pander to games publishers - we say what we really think.
- We only use experienced, professional reviewers.
- We won't bore you with mountains of technical-jargon-hardware tedium.
- We take games seriously, because you do too.

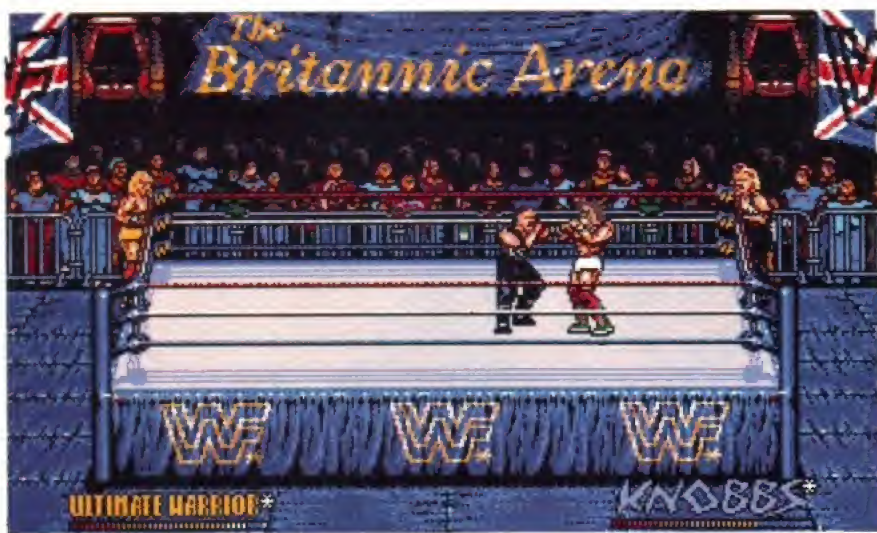

They're big on satellite TV, they're even bigger in the good ole US of A, and they're absolutely tiny on the Amiga. If you bought your Amiga for its graphics, you'll find WWF's C64 style a real downer.

Here they are: four gaily painted masters of the over-theatrical wrestling trade. An unlikely bunch, really.



WWF Rampage's classy television-style presentation merely highlights the lousiness of the game.



AMIGA FORMAT

64

FEBRUARY 1993



European Rampage Tour

An insider at Ocean said of their new game, "If you think you're going to get something like last year's crap - forget it!" OK, it speaks volumes about last year's tactics, but maybe we should give this year's offering a chance. After last year's effort, surely Ocean wouldn't unleash another dog on an unsuspecting public. Would they?

Meanwhile, in another dimension, we wake up and smell the coffee. WWF *European Rampage Tour* arrived too late for our pre-Christmas issue, but in time for the shops' Christmas crush. It will sell on the strength of its licence - and not one bad review, until it's too late. Which is unfortunate.

We would've told you so...

Those who bought before reading the AF review will have experienced its delights. But for those smart enough to hang on, read on...

The game begins with chrome-effect text screens and two fat uglies shouting "Whadda rush!". Cue sports-show music and flashy logos. A button-push later, you select one of the three types of wrestling match: one- and two-player tag-team, and a two-player practice mode. Then you choose your team from:

Randy Savage (snigger, snigger), Ultimate Warrior, Hulk 'The well-known one' Hogan and Bret 'Who he?' Hart. Choose two and select your controls. Player one uses joysticks or keys, with the second player using the second joystick only.

While fighting you get to read some guff on the wrestlers. After a while this gets annoying, because you can't skip it, and you have to read the whole tedious thing between each bout. This is made worse because WWF won't recognise an external disk drive. But even this is preferable to what happens next...

You find yourself transported to C64-land where the graphics are not the sleek-and-smooth digitised things they were a moment ago. Nope, we're back to poor-quality, lumpy-pixel sprites and second-rate, 2D backdrops.

When you start moving, the word sluggish springs to mind. Try a run by double-clicking with the joystick left or right, and you see an excuse for a running wrestler. If Randy Savage saw the way he's made to mince along, he'd be looking for a few Ocean heads to bust.

This game is aimed at WWF-influenced kids or those with a short attention span and no taste. You can strut around the ring, desper-



ately trying to find your opponent's collision-detection, or try a special move. These are entertaining, but seldom useful in a punch-up (the method favoured by the predictable computer opponents). You can roll on the floor, or even throw your opponent out of the ring and then jump out on top of him, but it's not really a meal for one, let alone two players.

Same idea next year?

WWF is a triumph of presentation over gameplay. The theme tunes and effects glide along with the slick opening titles. But that's it. There are only six opponents to beat twice, then the legion of doom to take and you've won the whole thing. And there are only four guys to choose from on your side. The kids will be disappointed - a fact you can judge for yourself when they've given it up by Boxing Day. Happy Last Year, all over again.

Neil Jackson



In a wrestling game, controlability is everything. But the modes on offer in WWF are a bit limited to say the least.

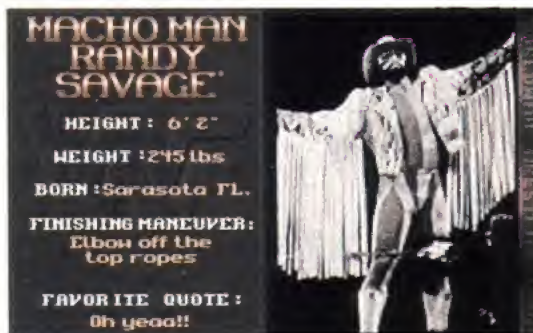

Nice bloke, nice coat, but he looks a complete pillock in the actual game. Will he be a happy man when he finds out?

WWF European Rampage Ocean ■ £25.99

- Eh? Where's the game? Compared to *Streetfighter 2*, this is sad, sad, sad.
- Ropy controls and chuck-inspiring in-game graphics spoil what's there.
- Nice front-end, lovely music and some God-awful gameplay.
- About as pleasant to play with as a wrestler's jockstrap.
- Nooooo! Not again! Take it away George: "Last Christmas, tra-la-la la..."



18%



New team on the block, ICE, have taken a subject close to every programmer's heart and turned it into a trading game.

Piracy

ICE ■ £29.99

Piracy, as Robert Maxwell would have told you, is a tricky profession. Admittedly its image has been improved by the pursuits of Guybrush Threepwood and co, but it's still a bloodthirsty way of life for aspiring crusty sea dogs. Except the whole concept's been gloriously sanitised in this strategy cum beat-em-up game.

Anyway, you've got a ship, 150 duckets, a couple of ship mates and a lot of sea to explore. By trading and robbing for treasure you can increase your personal wealth and thus purchase larger, quicker ships and more salty shipmates to man them.

With a bit more thought this could have been a promising trading game in much the same way as *Elite* was. In effect it's inordinately tedious. The fighting sections are shoddily executed with sluggish controls, the sea journeys are boring, the adventuring content is minimal and the trading's duff. I can find little to recommend this game except that one of the islands is called Melon.

Andy Hutchinson



Getting yourself orientated can take a long time because there isn't an annotated screenshot of the cockpit and its displays.

AV8B Harrier Assault

Domark ■ £39.99

Great things were expected from this flight sim, fresh from the makers of the excellent *MiG-29 SuperFulcrum*, but sadly, the result is a let-down. On an A500, you'll go nuts trying to hold the feisty Harrier on the straight and level, and that's before you even touch the rotating jet nozzles which make it so famous. It's not a bad simulation; it's just not a very good one. The A500 is unable to provide a quick enough frame update, resulting in uncontrollability all round. An A1200 provides much better results, but sadly, *AV8B Harrier Assault* still suffers from a few control problems which make life difficult.

The manual is written for the PC and refers to things you can't get to work on the Amiga. It's badly arranged, with tutorials in the middle, explanations in random places and the key-info tucked in the midst of heaps of text. It's a realistic sim with a huge strategy element, and loads of annoyances which destroy the fun.

Neil Jackson



LOOK NO FURTHER!!

FOR THE CHEAPEST AND BEST !!
THE LATEST TOP 50 GAMES FOR YOUR AMIGA:

3D Construction Kit 2	£34.99
A10 Tank Killer	£22.99
Addams Family	£15.99
Airbus A320	£24.99
Aquatic Games	£15.99
Assassin	£15.99
Beast 3	£19.99
Big Box 2 (10 games)	£19.99
Bug Bomber	£15.99
Catch'Em	£15.99
Championship Manager	£15.99
Civilisation	£22.99
Crazy Cars 3	£15.99
Curse of Enchantia	£22.99
Dune	£19.99
F1 Grand Prix	£22.99
Fire & Ice	£15.99
Golf (Microprose)	£22.99
Hagar the Horrible	£15.99
Harrier AV8B	£27.99
Head to Head (Mig29 vs F19)	£22.99
Humans	£19.99
Jaguar XJ220	£15.99
Jimmy Whites Snooker	£14.99
John Madden's	£15.99
Kick Off 3	£15.99
Kings Quest 5	£25.99
Leisure Suit Larry 5	£25.99
Lemmings 2	£15.99
Lotus 3	£15.99
Lure of the Temptress	£19.99
Megalomania/First Samurai	£19.99
Monkey Island 2	£24.99
Nigel Mansell GP	£15.99
PGA Golf	£19.99
Pinball Fantasies	£15.99
Pool	£15.99
Premiere	£19.99
RailRoad Tycoon	£22.99
Red Baron	£22.99
Sensible Soccer	£15.99
Silly Putty	£15.99
Space Crusade	£15.99
Space Shuttle	£34.99
Special Forces	£22.99
Street Fighter 2	£17.99
Striker	£15.99
Sword of Honour	£15.99
Wing Commander	£19.99
Zool	£15.99

The above represents only a very small selection of titles that we stock. If you do not see what you want listed, please give us a call.

Given the nature of games publishers, we can not guarantee that all the above will be released by the time this advert appears. Please call us to check availability to avoid disappointment.

Post & Packaging £1.50 - Securicor £5

48 hour despatch (cheques 7 days)

Cheques should be made payable to SoftStore

Access and VISA cards accepted

SoftStore, Dept DAF, PO Box 1720, Slough,
SL3 0YX

0753-683336



AMERICA'S LARGEST SUPPLIER OF AMIGA CUSTOM CHIPS + UPGRADES



8372A 1 Meg Agnus inc. chip puller.....£27.00	8373 Super Denise.....£19.00
8375 (A500+/A600) 2 Meg Agnus.....£25.00	8520A CIA (2MHz) Great price.....£6.35
1.3 Kickstart ROM.....£14.00	6570-036 Keyboard chip.....£7.95
A500 Keyboard - factory new.....£26.50	A500 original P/S, 220 volts.....£25.00
5719 Gary.....£10.44	A2000 original P/S, 220 volts.....£60.00
8362 Denise + bright.....£13.90	

- A500 PC Motherboard-PAL, 220 volts populated & tested (new low price) Rev. 3.....£54.00
- Amiga 2000 Computer: PAL, 220 volts includes 1.3 ROM, 8372 Agnus, Super Denise, new keyboard, mouse and owner's manual. Comes with 90 day warranty. These units are reconditioned and were used as demonstrators. Shipping extra. Must pay VAT & duties. Once-in-a-lifetime offer.....£362.50
- 2.04 ROM (chip only - no manual or diskettes).....£20.50
- Advanced Amiga Analyser: Sophisticated but easy to use (hardware & software). Checks status of all data transmissions/signals, disk drive, ports, buffer chips, alignment, joystick + mouse. Checks status of read/write errors and tells what chips are bad. A must for all individuals and repair shops.....£45.50

MICROCARD 601: RAM MEMORY CARD FOR A600/A600HD/A1200
A credit card sized memory offers up to 4 additional megs of dynamic RAM via the PCMCIA slot. Auto-configures at boot time, leaving most internal chip RAM free for image processing.
2MB card/4MB card.....£98.00/£132.00
Available soon: 2MB PCMCIA with built in battery.

- MegAChip 2000 by DKB: Upgrade your Amiga to 2Mbof chip RAM. Includes 2 meg Agnus, chip puller & "Final Test." No soldering required. Same 8372B chip used in A3000.....£142.00
Buy the MegAChip from us and we'll give you the new Super Denise for.....£17.00
- Switch-It: America's most popular ROM switch with speaker, keyboard controlled. Does not overlap the 68000.....£15.00
- AdRAM 540 for A500 by ICD: Add up to 4 megs of RAM with battery backup internally in your A500. 1 Meg/2 Megs (install up to 4 megs).....£74.20/£95.15

DO NOT FEAR!

Buying directly from the U.S. with your credit card offers you the same protection as it does in the U.K. with the added benefit of saving lots of money. Deal directly with North America's largest distributor of custom Commodore & Amiga parts and chips. The Grapevine Group has been successfully servicing the U.K. and the Continent for 12 years. All our parts and chips are new and guaranteed for 90 days.

DEALERS - SEND YOUR LETTERHEAD FOR SPECIAL PRICING

PRICES JUST
REDUCED

THE GRAPEVINE GROUP INC.
3 Chestnut Street, Suffern, New York 10901 U.S.A.

Prices
now include
VAT, Customs
and duty if any



International Fax: 0101-914-357-6243
Customer Order Line: 0101-914-357 2424
Telephone Hours: 1pm to 11pm Mon-Fri British time

Prices subject to change. **International Orders:** If your order is over £40 send or fax front of credit card. **Air Parcel Charges:** All chips - £5.36 Keyboard & PCBoard - £8.40 2.0 Kit - £22.62

BUILD MUSCLES FAST

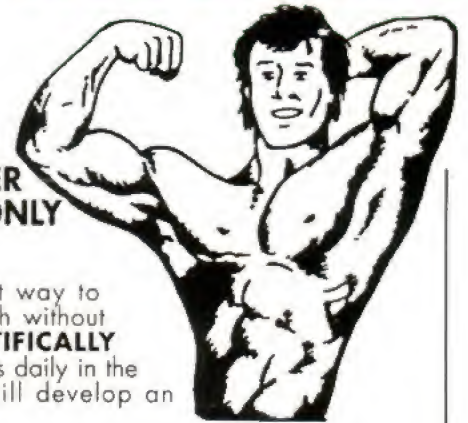

**YOU CAN BUILD
A FANTASTIC POWER
PACKED BODY IN ONLY
12 WEEKS!**

NEW! Fastest and best way to build muscles and strength without weights - **EVER!** **SCIENTIFICALLY PROVEN.** Just 20 minutes daily in the privacy of your home will develop an amazing physique.

MUSCLE DYNAMICS is a new bodybuilding system based on principals developed after years of exhaustive research. It is a total exercise programme involving the very latest scientific breakthroughs in the field of muscular development. It is the fastest, most effective way to build muscles in existence.

NOTICEABLE RESULTS IN 28 DAYS GUARANTEED
Send for exciting **FREE** information pack today

MUSCLE DYNAMICS (AF)
PO BOX 70, DOUGLAS, ISLE OF MAN

Yes! I want to build muscles fast. Please rush me my **FREE** information pack!

Name.....

Address.....

Postcode.....

(A Stamp for reply appreciated)

MATRIX SOFTWARE CLUB

As a Matrix member you can choose from our extensive lists of the latest and the popular software with our absolute guarantee to buy them back. AND you don't have to pay until you've decided.

- TOP NAME
- GAMES, BUSINESS AND UTILITY SOFTWARE (sorry no PD or Shareware)
- NO COMMITMENT TO BUY
- SUPER FAST SERVICE • ESTABLISHED 1981
- OVER 2,500 MEMBERS

To find out about the unique Matrix money saving scheme call our 24 hour hotline 0920 484479

Or send a large s.a.e. stating your machine (IBM/PC 3.5", Amiga, Atari ST) for

Matrix Computing Services, Dept AMF2, 2 Frenchs Yard, Amwell End, Ware, Hertfordshire SG12 9HP

**BUY YOUR
SOFTWARE
FROM US.**
**WE'LL BUY
IT BACK!**

MCS

AMIGA POWER SUPPLY

- Genuine Commodore
- One year warranty
- Free mouse
- Fast Delivery

ONLY
£29.99

Cheques/PO to:
Ominidale Supplies,
23 Curzon Street,
Derby DE1 2ES.
Tel: (0332) 291219

OR part exchange your old power supply and pay:
£19.99



FREEWHEEL® PERFECT CONTROL FOR ULTIMATE REALISM

Just imagine, sitting in your favourite armchair and driving MicroProse Grand Prix with a replica racing car steering wheel. Freewheel® has five buttons on its inside rim, just like the real thing. Freewheel is described as a Virtual Steering Wheel because you sit back in your seat in a comfortable position and simply hold the wheel giving you 140° of analog movement, when turned left or right. Tilt forwards to accelerate and backwards to brake, the amount of acceleration and braking depends on how much you tilt.

Freewheel® Analog was designed with MicroProse Grand Prix in mind and lets you use your real driving skills to win races and as such is the ultimate accessory for budding 'Nigels'!

£39.95 RING FOR SPECIAL OFFER

R. C. Simulations

UNIT 16 BEEHIVE TRADING ESTATE, CREWS HOLE ROAD,
ST GEORGE, BRISTOL BS5 5AY
TEL: (0272) 550900 FAX: (0272) 411052

If information only required, please enclose s.a.e quoting interest
Prices exclude p&p. Please add £1.95
Please allow up to 21 days for delivery



MAKE YOUR AMIGA EARN!

Yes, making money with your AMIGA becomes incidental when you know how! Your AMIGA is, if only you knew it, a gold mine. The size and make is irrelevant. Make the initial effort NOW by starting your own HOME BASED BUSINESS.

This may be the most important move you will ever make!

REMEMBER: You'll never get rich by digging someone else's "ditch". Anyone in the country, including YOU, can become very rich in a relatively short period of time just by doing a few basic things! It's more rewarding than playing games.

The benefits are many and varied.
Full or part time.

For **FREE** DETAILS SEND S.A.E. to:

Home Based Business.

AF38, 31 Pilton Place, King and Queen Street,
Walworth, London SE17 1DR.





Directions



for Great Value Packed Prices on Amiga Computers, Accessories and Peripherals there is only ONE Direction!

Amiga Computer Range

Whether you are looking to buy your FIRST Amiga, upgrade to a NEWER model or add to your existing system, Merlin Express have got the product for you. With truly competitive prices plus Merlins' expert advice and service, why not give us a call? Remember with all Amiga 600 computers you get a full 1 Year IN-HOME warranty plus an advice helpdesk that are only a phone call away! In the rare event that a fault occurs an engineer will call at your home to sort out the problem free!

With Merlin Express you automatically receive the following with every Amiga pack...

- ◆ TV Modulator [allowing your own TV as a display] ◆ Mouse
- ◆ User Manuals ◆ Connecting Leads ◆ Operating System Disks

Amiga Welcome Pack

Amiga A600 package with 3.5" floppy disk drive and the following great software [whilst stocks last]...

- ◆ Deluxe Paint III - Paint Package
- ◆ Commodore 'Mystery Game'
- ◆ GFA Basic - Programming

£Special!!!
Phone us!

A600 Wild, Weird & Wicked

Amiga A600 package with 3.5" floppy disk drive and a fantastic collection of superb quality software...

- ◆ Microprose Grand Prix
- ◆ Silly Putty ◆ Pushover
- ◆ Deluxe Paint III

£Wicked Price
Phone us!

Amiga 1500 Home Office

Amiga A1500 package with twin 3.5" floppy disk drives and 1Mb RAM plus Games and Business software...

- ◆ THE WORKS PLATINUM EDITION [Word Processor, Database, Spreadsheet] ◆ HOME ACCOUNTS ◆ DELUXE PAINT III ◆ ELF ◆ TOKI ◆ PUZZNIC & a great book: "GET THE MOST OUT OF YOUR AMIGA"

£539.99
Only...

EPIC-20Mb Hard Disk

Amiga A600 package with 3.5" floppy disk drive and a 20Mb Hard Disk Drive built-in and installed - 'Ready To Go', plus superb quality software...

- ◆ EPIC ◆ MYTH ◆ TRIPLE LANGUAGE TRIVIAL PURSUIT ◆ ROME ◆ DELUXE PAINT III
- ◆ 5 LANGUAGE DICTIONARY ◆ AMIGA TEXT [Word Processor]

£399.99
Great Family Pack

EPIC PACK [as above] but WITHOUT the software available subject to availability...Phone Us!!!

CDTV Packs

A new concept in home education and entertainment for all the family. All the features of home computing [with a CDTV keyboard & disk drive] plus CD Rom technology...full interaction!

Welcome CDTV CDTV Multimedia Pack

A great new pack with CDTV Unit, Welcome CD Disk, Remote and both Hutchinsons Encyclopaedia and Lemmings [whilst stocks last] on CD Disk.

£369.99
New Lower Price

£459.99
FREE Fred Fish CD-Over 600Mb. of S/W

Dot Matrix Printers

500 Compatible 500+ Compatible A600 Compatible 1500/2000/3000 Compatible CDTV Compatible

star		9PIN	
LC20 Mono			£134.99
LC100 Colour	NEW!		£164.99
LC200 Colour			£194.99
ZA200* Colour			£Phone
ZA250* Colour			£Phone

star		24PIN	
LC24-20 Mono			£199.99
LC24-100 Mono	NEW!		£189.99
LC24-200 Mono			£219.99
LC24-200 Colour			£264.99
XB24-200* Colour			£349.99

CITIZEN		9PIN	
120D+ Mono			£129.99
Swift 9 Mono			£179.99
Swift 9 Colour			£184.99
ProDot 9* Mono			£Phone
ProDot 9* Colour			£Phone

CITIZEN		24PIN	
Swift 200 Mono			£219.99
Swift 200 Colour	NEW! RANGE		£PHONE
Swift 240 Mono			£249.99
Swift 240 Colour			£269.99
and whilst stocks last...			
Swift 224 Colour			£SPECIAL
Swift 24E Colour			£SPECIAL
Prodot 24* Mono			£Phone
Prodot 24* Colour			£Phone

Printer Starter Pack

200 Sheets Continuous Paper
5 Continuous Envelopes
100 Com. Address Labels
1 Amiga Driver Disk [quote
Star/Citizen when ordering]

Only...
£9.99
with a printer
[or £17.99
separately]

Merlin carry a full range of Star and Citizen accessories and consumables including Ribbons, Memory Upgrades, Sheet Feeders etc. Phone us for details/prices.

Printer Freebies

With Dot Matrix Printers* from Merlin you get... a Quality Dust Cover, Cable to your Amiga and a Two Part Printer Stand ALL FREE OF CHARGE!

[Dust covers not available for any of our printers marked with an (*) thus

WORTH OVER £25 if purchased separately!]

Amiga A600 with 2Mb. RAM

Increase your A600 RAM to a full 2Mb. when you buy your computer for a special price of:

£39.99

GVP Product Range

500 Compatible 500+ Compatible 1500/2000/3000 Compatible

HD+/II Hard Drives
Simply attached into the side port of your Amiga A500/A500 Plus computer...

0Mb. HD+/II Unpop.	£189.99
52Mb. HD+/II Unpop.	£329.99
120Mb. HD+/II Unpop.	£409.99
240Mb. HD+/II Unpop.	£659.99

6550 Combo Boards
Simply attached into the side port of your Amiga A500/A500 Plus computer... All units are 40MHz and come with 1Mb. of 32Bit RAM installed.

52Mb. - 1Mb. RAM	£629.99
120Mb. - 1Mb. RAM	£719.99
240Mb. - 1Mb. RAM	£929.99
68882 Maths CoProcessor	£209.99

[for use with A530 Combo Boards, above]

A500 Hard Cards
Fits internally in your A1500...

0Mb. Unpopulated	£129.99
52Mb. Unpopulated	£274.99
120Mb. Unpopulated	£399.99
240Mb. Unpopulated	£619.99
420Mb. Unpopulated	£979.99

GVP Memory Upgrades
Upgrades for HD8+/II and A1500 Hard Cards [SIMMS 1Mb. or 2Mb.]

2 x 1Mb. Chips	£49.99
4 x 1Mb. Chips	£99.98
2 x 4Mb. Chips	£199.99

Upgrades for Combo Boards [32Bit SIMMS 1Mb. or 4Mb.]

1Mb. Chip	£69.99
4Mb. Chip	£164.99

Other GVP Products

PC Emulator to fit HD+/II or A530 Combo Boards	£199.99
Digital Sound Studio 1600[Hz]	£59.99
G-Force 1500/2000 Accelerators	
030-25MHz + 1Mb.	£569.99
030-40MHz + 4Mb.	£799.99
030-50MHz + 4Mb.	£1099.99
Hard Drive fitting Kit for G-Force that allows mounting of SCSI Drives	£39.95

GVP - OPTICAL & SYQUEST REMOVABLE DRIVES AND GVP IMPACT VISION 24 AVAILABLE TO ORDER. £Phone Us

3.5" Second Drives

Commodore 1011 Drive	£54.99
Cumano CAX 354	£54.99
NEW! Roelite 3.5" Anti-Virus Floppy Disk Drive... Enable or disable the anti-virus checker that is built into the hardware!!! Makes sure your disks don't carry viruses!!!	£64.99
Roelite 3.5" Ultra Slim Disk Drive in black for use with the CDTV	£64.99

CDTV ROM Drive

A500 Plus CD ROM
Turn your Amiga A500 Plus into CDTV! Simply plugs into the end port of the Amiga to allow CDTV software and music CD with stereo outputs

£329.99

Philips Displays

Choose between a specific monitor for the optimum display quality or a TV/Monitor which is better quality than a domestic TV [almost as good as a monitor] but with the advantage of Television too!

CM8833/II Monitor

14" Colour complete with lead to your computer and a quality dust cover plus...

LOTUS TURBO CHALLENGE 2

Television Monitors

2000 Line resolution to surpass the display of a domestic television...

3332-15" Remote with SleepTimer **£219.99**
2331-15" Remote/Sleep/Teletext **£249.99**
2341-17" Remote/Sleep/Teletext **£299.99**

TAKE £10 OFF WHEN PURCHASED WITH AN AMIGA OR OTHER MAJOR HARDWARE

Merlin Value Sorcerers Packs

Add a Sorcerers pack to your Amiga for EXTRA VALUE, choose:

Sorcerers Pack 1: £19.99

Mouse Mat, Dust Cover, 10 Blank Disks, Library Case, Quality Joystick

Sorcerers Pack 2: £24.99

Amiga Games Pack. All professional software NOT cheap PD titles: DataStorm/Dungeons Guest/E-Motion/KidGloves/Grand Monster Slam/Powerplay/RVF Honda/Shuffle Puck Cafe/Microprose Soccer/Tower of Babel and GFA Basic Programming

Sorcerers Pack 3: £24.99

THE 'ZOO' PACK
New software package including the game 'ZOO!' which could be this years BEST seller!!! You get Zool, Pinball Dreams, Striker and Transwiter [Amiga WP]. The rps's for this pack total more than £125 separately!!!

Prices are when purchased with an Amiga.

New Christmas Sorcerers Packs due in for EXTRA VALUE...Phone Us Now!!!

MerlinExpress Limited

Dept AMS, Unit C7, The Ropewalk Industrial Centre, Station Road, Ilkeston, Derbyshire. DE7 5HX. Telephone: 0602 441442 FAX: 0602 440141

Order-Line:

0602 441442

Delivery: Hardware and larger items are dispatched by courier at a cost of either £7.50 for a next working day service or £6.00 for two working days. Sunday delivery is available at just £12.00. Smaller items are normally posted and all goods are generally dispatched on day of payment clearance.

Export: Merlin are happy to supply BFP & Export markets[VAT usually deducted]. Delivery charges vary from UK and all warranties are for UK only.

Payment: Payment may be made by Switch, Facilities: Access, Visa, Cheque [please allow 7 working days for clearance]. Bank or a Building Society Draft [which require no clearance]. Postal Orders or cash.

Warranty: Hardware warranties allow for 30 days refund or replacement [subject to manufacturers conditions etc]. After 30 days & within 12 months of purchase faults are rectified by relevant makers repair schemes. Software & small items carry various warranties, please ask for details. Goods which carry an 'on-site' guarantee are attended to by the makers own nominated service agents.

General Details: All information is correct at time of going to press. E&OE. Every effort is made to ensure the information in this advert is correct, but you should always confirm any offers, prices, availability etc., PRIOR to placing your order. We reserve the right to alter product prices or specification without prior notice [please note prices may fluctuate up OR down]. Goods are not supplied on a trial basis.



Women swoon over him, men envy him and every movie executive in the world wants him. But **Amiga Format** tracked down **Chris Buxton** and got him to review Ocean's...



Instead of a boring menu system, *Lethal Weapon* has Police HQ. Here Riggs and Murtaugh can walk around and go through the various doors to select different mis-

sions, save-game positions and choose which of the two cops to take on the next mission. In an orgy of special FX the secretaries actually turn when you walk past them!

AMIGA FORMAT

68

FEBRUARY 1993

Lethal Weapon

Ho hum, another movie tie-in. Well, the *Lethal Weapon* movies have been around for about four or five years now, and show no signs of getting any more original with age. They're based around two cops with contrasting characters – a placid family man and a wild, disrespectful renegade – who, braving every cliché in the book, overcome their differences, work together to fight corruption and have a few jokey male-bonding scenes along the way. Usually at a hot-dog stand. Hollywood thought long and hard about this one. Oh dear, this is all getting a bit cynical. Still, let's take a look at the facts.

Action men

Successful action movie becomes computer game. Any votes for a complex simulation? A *Monkey Island*-style adventure? How about a platform shoot-em-up then? Staying true to the

film's lack of innovation, the programming team have come up with a good old left-to-right, scrolling platform game. But, let's face it originality was never an essential quality for a great game.

The plot is based loosely on the three films and the main characters look roughly like Mel Gibson and Danny Glover. The action starts off in police headquarters where Riggs and Murtaugh (Gibson and Glover) have to solve three cases in order to get a special assignment. When they finish the special assignment they get drafted into Internal Affairs and go after some corrupt big-wigs in the force who've been selling off confiscated firearms (yes, a little bit of politics, there).

The first three cases can be attempted in any order but the manual recommends that you take case one first, then case two and finally case three. So much for freedom of choice.



There's another decision to be made before you can get down to action – which of the cops to have. Riggs is better at hand-to-hand combat, while Murtaugh carries a more powerful gun, but again the game dictates your choice. Some levels are full of extra ammunition, so you'd be a fool to pick Riggs and his weedy gun. In other levels the ammo's thin on the ground so Murtaugh is out of the question.

Sewer bound

With your 'selections' made it's off to the first case. The dynamic duo must capture the profits of a drug cartel that are stashed on a ship at the harbour. The second case has them exploring the city's sewers searching for terrorist bombers, and in the third they've got to rescue an informant from a derelict factory.

The object of each mission may differ but they all play in the same way. The standard mix of running along shooting heavies, jumping on to moving platforms and picking up power-ups and energy refills doesn't change from level to level. The enemies always appear in the same places. They always fire in the same way. There's an easy route across the platforms, or you can risk losing a life and go for a hard-to-reach bonus or power-up. And after a couple of levels, at the end of each case, there's a boss villain who needs a massive load of hits to destroy.

So far all this seems OK, and it is. The graphics are crisp and the locations look good – more colour and some parallax wouldn't have hurt, though. The music's not bad and the sound of the thudding impact of the bullets is

THE CASE OF THE MYSTERIOUS PLATFORMS

All over the city strange platforms were appearing. Riggs and Murtaugh smelt a conspiracy...



Case one – The Export Gang. The mission – a search for stolen cash. The game – platforms as far as the eye can see.



Case two may be about stopping a terrorist bomb squad but it's much the same old platforms as Case one's docklands.



Case three breaks off at a real tangent – saving a kidnapped informant – and goes for an all-new, er, platform look.

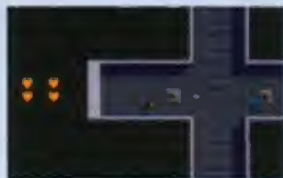

Case number four is classified so I can't talk to you about it. I did get there though, honest. No, straight up, I did. Trust me.



In the final case the cops have to sort out their corrupt bosses: or are they just minding the car park? I could never work it out.



There's nothing worse than a bad guy wielding several sticks of dynamite. Especially when he's standing guard over the only two extra cartridges you've managed to find in the whole level.

suitably gruesome. But after an hour of plugging away you begin to get the impression that there isn't a whole lot to *Lethal Weapon*.

When you've overcome the initial urge to race through every level with guns blazing you'll find the only way to make it through a case with your lives intact is to plod along waiting for an enemy to appear, dodge their fire, take 'em out and go on to the next one. The platforms' layout make things tricky and when you first go through a level it's hard to tell if some are platforms or are just part of the scenery - until you plummet off screen and lose another life.

Once you know where to go and when to shoot, the game gets frustrating because you just want to get on with it and not have to wait around for the right moment to fire or jump. All this timing and practice is what platformers are all about, so what's the problem? Well, when it becomes irritating instead of challenging you know the game's not for you. If the game had played a bit quicker, had a few more enemies here and there, maybe (Heaven forbid!) tried something new it could be something more than what it is. There are no deep, or even shallow puzzles and even the slightest bit of detective work would make the game interesting. As it is there's only one route through each of the levels and the occasional door switch to push, and it's never a million miles away from the door.

All these niggly points show just what an



And the winner of the 'Nicest Platform In This Game' award is the girder swinging on a chain.

ordinary game *Lethal Weapon* is. It isn't badly programmed, it all works very slickly and will probably give anyone who buys it a few days' fun. But there's nothing impressive about it all - even as it stands, a simultaneous two-player mode could have rescued it. No, it's just a desperately average game that's almost identical to every other platform game you've bought, played and can now see on sale at £9.99 on a budget label.

“ A desperately average game that's almost identical to every other platform game around ”

If you're thinking about buying this because you're a fan of the films, you'll find little to link the game with the movie apart from a nice picture of Mel, Danny and the stumpy one with grey hair who's not done anything decent since *Raging Bull* on the box. (*What about Goodfellas?* - Ed.) If you're thinking about buying this because you want another platform shoot-em-up, think again.

What's here is nothing new and you already have something similar in your software stash. Technically it would be at home on an 8-bit console, not an Amiga. These sort of games need to be noisy, dazzling, fast and frantic, as the console ads on TV scream at us, and sadly this game hasn't kept with the pace.

Chris Buxton ☺

Lethal Weapon Ocean ■ £25.99

- Uninspired platform shoot-em-up that feels like you've played it before. A dozen times.
- Uninspired platform shoot-em-up that feels like you've... ooh, I've just had an incredible feeling of déjà-vu.
- No frills in the presentation but graphics look good enough and the in-game music is pretty good too.
- Not abysmal, not outstanding and not really worth it.

Verdict **64%**

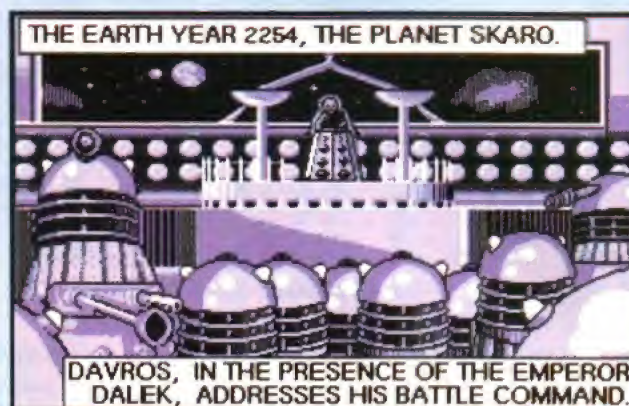

Considering that they are one of the most evil creations in the universe, Daleks look pretty stupid. And anyway, how do they get up stairs?

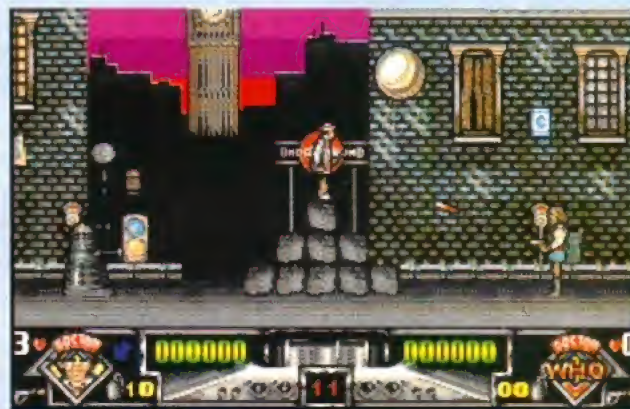

The Doctor reaches the London Underground only to find that the 4.25 to Marble Arch has been delayed, but that's the least of his worries.

Dalek Attack

Alternative ■ £15.99

It was way back in 1963 that William Hartnell, the first Doctor Who, emerged from his police box Tardis, and a whole generation of impressionable young children spent much of their lives cowering behind the couch, peeking out now and again to see how the most famous Time Lord in the universe was faring in his battles against the Daleks, the Cybermen, the Yetis, the Autons, the Ice Warriors and various other intergalactical bad guys.

So it's strange, in many ways, that it has taken so long for The Doctor to find his way on to your Amiga screen in the form of *Dalek Attack*. The action is set in the year 2254 when the Daleks and their evil creator Davros have taken over the world. Their evil plot is to turn the planet into a munitions factory to supply the Dalek armies.

The Doctor must thwart their terrible aims by running around a series of platforms, blasting various baddies and rescuing hostages. It's worth mentioning here that not all the enemies are Doctor Who originals but include Ninjas and others who have absolutely nothing to do with the TV series. Anyway, after a promising introduction level, *Dalek Attack* is a tad disappointing.

Although the graphics are well drawn and the music is of a reasonably suitable variety, the character animation is none too hot. Basically it's the gameplay that really lets down *Dalek Attack*. It would be better if it wasn't a shoot-em-up, and even better still if it wasn't so predictable - whenever you walk through a door there's inevitably a couple of Daleks waiting to exterminate you. Actually there's an important aside here. Daleks roll around on wheels, they are incapable of jumping, so how the hell do they get up stairs. Obviously they can't. And if they can't how did they take over the Earth. Not much good just taking over the downstairs bit of the Earth, is it?

Anyway, this is only an average game, admittedly at a good price. But as anybody who has taken a serious interest in Time Lords will tell you, the essential point about Doctor Who is to outwit the enemy by skillful use of time travel, and sonic screwdrivers, and by having pretty women as assistants and cute mechanical dogs called K-9, so this would have been a better game if it was an adventure instead of a shoot-em-up.

Dave Paget ☺

Verdict **59%**

CRAZY NEW YEAR

LOOKING FOR DISKS & BOXES???
LOOK NO FURTHER
 REMEMBER ALL DISKS SOLD BY BCS ARE FULLY GUARANTEED

DISKS ! DISKS ! DISKS !

100% CERTIFIED ERROR FREE
PLUS FREE COLOUR CODED LABELS

50 3.5" DS/DD	£22.99
100 3.5" DS/DD	£40.99
150 3.5" DS/DD	£56.99
200 3.5" DS/DD	£73.99
300 3.5" DS/DD	£109.99
400 3.5" DS/DD	£144.99
500 3.5" DS/DD	£175.99
1000 3.5" DS/DD.....	CALL FOR LATEST PRICE

All prices include VAT/free labels.
REMEMBER, THESE PRICES INCLUDE FREE DELIVERY

DISKS + 100 CAP LOCKABLE BOXES

100% CERTIFIED ERROR FREE
PLUS FREE COLOUR CODED LABELS

50 3.5" DS/DD + 100 cap box.....	£25.99
100 3.5" DS/DD + 100 cap box.....	£43.99
150 3.5" DS/DD + 100 cap box.....	£60.99
200 3.5" DS/DD + 2 x 100 cap boxes	£78.99
300 3.5" DS/DD + 3 x 100 cap boxes.....	£117.99
400 3.5" DS/DD + 4 x 100 cap boxes.....	£154.99
500 3.5" DS/DD + 5 x 100 cap boxes.....	£186.99
1000 3.5" DS/DD + 10 x 100 cap boxes.....	£ call

All prices include VAT / free labels
REMEMBER THESE PRICES INCLUDE FREE DELIVERY

DISKS + 80 CAP BANX BOXES

100% CERTIFIED ERROR FREE
FREE COLOUR CODED LABELS

50 3.5" DS/DD + 80 Cap Banx Box.....	£31.99
100 3.5" DS/DD + 80 Cap Banx Box.....	£48.99
150 3.5" DS/DD + 2 x 80 Cap Banx Boxes.....	£72.99
200 3.5" DS/DD + 2 x 80 Cap Banx Boxes.....	£90.99
300 3.5" DS/DD + 4 x 80 Cap Banx Boxes.....	£143.49
400 3.5" DS/DD + 5 x 80 Cap Banx Boxes.....	£187.99
500 3.5" DS/DD + 6 x 80 Cap Banx Boxes.....	£224.99

All prices include VAT/free labels & free delivery

DISKS + 150 CAP POSSO BOXES

100% CERTIFIED ERROR FREE
FREE COLOUR CODED LABELS

50 3.5" DS/DD + 150 Cap Posso Box.....	£35.99
100 3.5" DS/DD + 150 Cap Posso Box.....	£53.99
150 3.5" DS/DD + 150 Cap Posso Box.....	£68.99
200 3.5" DS/DD + 2 x 150 Cap Posso Boxes.....	£100.99
300 3.5" DS/DD + 2 x 150 Cap Posso Boxes.....	£135.99
400 3.5" DS/DD + 3 x 150 Cap Posso Boxes.....	£185.00
500 3.5" DS/DD + 4 x 150 Cap Posso Boxes.....	£227.99

All prices include VAT/free labels & free delivery

3.5 DELUXE STORAGE BOXES

10 Capacity	£1.00
40 Capacity (Lockable).....	£4.10
100 Capacity (Lockable).....	£4.50

5.25 STORAGE BOXES

10 Capacity	£1.00
50 Capacity (Lockable).....	£5.10
100 Capacity (Lockable).....	£5.90

STACKABLE BOXES

3.5" 80 Cap Banx Lockable Box	£9.95
3.5" 150 Cap Posso Box	£15.50
5.25" 70 Cap Posso Box	£16.50

3.5" HIGH DENSITY DISKS

100% ERROR FREE / FREE COLOUR CODED LABELS

60P EACH £61 For 100 incl delivery/labels/VAT

100% CERTIFIED ERROR FREE

5.25" DS/DD Disks	21p each
5.25" DS/HD Disks	39p each

BRANDED 3.5" DISKS (KAO/TKD)

10 3.5" DS/DD	£6.50
10 3.5" DS/HD	£10.50

BOX OF PAPER 11 X 9.5, 60GMS MICROPERF 2,000 SHEET...£11.75

BOX OF A4 PAPER, 70GMS MICROPERF 2,000 SHEETS...£12.95

**AMIGA / ATARI
 NAKSHA MOUSE
 £22.50
 AMAZING PRICE!**

**A570 CD ROM DRIVE
 ALLOWS YOU TO LOAD & PLAY CDTV
 Software on your Amiga
 BCS Price only £318.00**

PRINTER RIBBONS

PRINTER	BLACK RIBBONS		COLOUR RIBBONS
	BRANDED	COMPATIBLE	BRANDED
Citizen 120D	£3.40	£2.70	N/A
Citizen Swift 9	£3.40	£2.70	£15.30
Citizen Swift 24/24E/224	£4.70	£2.70	£15.30
Panasonic 1124	£8.50	£3.58	N/A
Star LC-10	£4.47	£3.06	£6.70
Star LC-20	£4.47	£3.06	N/A
Star LC200	£6.11	£4.70	£12.30
Star LC24 10/15	£5.58	£3.53	N/A
Star LC24-200	£5.58	£3.53	£13.25

INKJET CARTRIDGES & REFILLS

HP Deskjet Black Ink Cartridge.....	£14.98
HP Deskjet Black Dual Capacity Ink Cartridge.....	£23.95
HP Deskjet 500C Colour Ink Cartridge	£26.96
Canon BJ10e/ex Black Ink Cartridge.....	£19.98
Black Twin Refill Kit	£14.98
Colour Twin Refill kit	£14.98
500C Colour Refill Kit	£14.98
Amiga Colour Separation Software	£39.95

OFFERS FROM BCS LTD

AMIGAS! AMIGAS! AMIGAS!

BCS ORDER HOTLINE 0273 506269 PHONE NOW

PACK 1

NEW AMIGA 600

**THE WILD, THE WEIRD, THE WICKED PACK
+ SUPERBASE PERSONAL SOFTWARE**

A600 1MB FDD
DELUXE PAINT III
MICROPROSE GRAND PRIX
SILLY PUTTY
PUSHOVER
SUPERBASE PERSONAL
MOUSE ETC
ON-SITE WARRANTY
ONLY £318.99

PACK 2

NEW AMIGA 20MB HD EPIC PACK + SUPERBASE PERSONAL SOFTWARE

A600 +20 MB HD
1MB RAM
TRIVIAL PURSUITS, EPIC, ROME
MYTH, AMIGA TEXT WP
DICTIONARY, MOUSE ETC +
SUPERBASE PERSONAL
SOFTWARE
ON-SITE WARRANTY
ONLY £458.99
A600 +20 MB HD (no software)
£419

PACK 3

NEW AMIGA 600 BCS PACK

A600 1MB FDD
SUPERBASE PERSONAL SOFTWARE
MOUSE ETC.
ON-SITE WARRANTY
10 3.5" DS/DD DISKS
DISK BOX
MOUSE MAT
TAILORED DUST COVER
MICROSWITCH JOYSTICK
ONLY £294.99
LIMITED STOCK

PACK 4

BCS STARTER PACK

10 3.5 DS/DD DISKS
DISK BOX
MOUSE MAT
TAILORED DUST COVER
MICROSWITCH JOYSTICK
3.5 CLEANING KIT

ONLY £17.00

WHEN PURCHASED WITH PACK 1, 2 OR 6

NEW ZOOL PACK INCLUDING:

ZOOL
STRIKER
PINBALL DREAM
TRANSWRITE WP
**ONLY £19.99 WHEN PURCHASED WITH
AN AMIGA. OTHERWISE £29.99**

PACK 5

PHILIPS CM8833 MK II
COLOUR STEREO MONITOR
LOTUS TURBO CHALLENGE
ON-SITE WARRANTY
UK SPEC'
CONNECTING LEAD
DUST COVER

ONLY 225.99

PACK 6

NEW AMIGA 1200

- 68020 PROCESSOR RUNNING AT 14.19MHZ
- 2MB CHIP RAM
- 16 MILLION COLOURS
- AA CHIP SET
- NUMERIC KEYPAD
- ON-SITE WARRANTY

ONLY £379.99
**OR £395.99 with
zool pack**

Limited stock - Call for latest price

GVP SERIES II HARD DRIVES & ACCELERATORS FOR A500

GVP 42MB HD8 II£325
GVP 80MB HD8 II£409
GVP 120MB HD8 II£482
GVP 240MB HD8 II£635
GVP A530 COMBO 40 MHz +80MB.....£775
GVP A530 COMBO 40MHz + 120MB.....£845
GVP A530 COMBO 40MHz + 240MB.....£999
CALL NOW FOR PRICES ON RAM UPGRADES
FOR GVP DRIVES

GVP SERIES II HC8 HARD DRIVES FOR A1500/2000

GVP 42MB HC8 II.....£255
GVP 80MB HC8 II.....£325
GVP 120MB HC8 II.....£395
GVP 240MB HC8 II.....£615
CALL NOW FOR PRICES ON RAM
UPGRADES FOR GVP DRIVES
Prices changing due to currency
fluctuations. Please phone.

AMIGA BIT'S 'N' BOBS

A500 1MB UPGRADE.....£29.00
A600 1MB UPGRADE.....£42.99
A600 2MB UPGRADE.....£123.00
A600 4MB UPGRADE.....£193.00
3.5 CUMANA DISK DRIVE.....£54.99

STAR/CITIZEN PRINTERS

CITIZEN 120D 9PIN MONO£129
CITIZEN SWIFT 9PIN COLOUR£179
CITIZEN 240 MONO£245
CITIZEN 240 COLOUR.....£268
STAR LC-200 COLOUR.....£199
STAR LC-24 200 COLOUR£259
SEKOSHA SL-90 MONO 24 PIN.....£185
ALL PRINTERS COME WITH LEAD & DUST COVER
CITIZEN PRINTERS HAVE 2 YEAR WARRANTY

ACCESSORIES/JOYSTICKS

1000 COLOURED LABELS£8.00
1000 TRACTOR LABELS (WHITE)£10.00
MOUSE MAT£2.75
MOUSE HOLDER.....£2.50
14" MONITOR STAND.....£10.00
PRINTER STAND.....£6.00
3.5" CLEANING KIT.....£2.75
CHEETAH BUG.....£12.99
PARALLEL LEAD.....£8.00
ZIPSTICK£11.50
QS PYTHON III£9.50
CHEETAH 125+£8.00
KONIX NAVIGATOR.....£14.99

DUST COVERS

A500£3.00
A600£3.00
STAR LC200£3.50
STAR LC-24 200£3.50
CITIZEN 9.....£3.50
CITIZEN 24.....£3.50
PHILIPS MKI/II.....£3.50
ATARI.....£3.00

WHY ORDER FROM BCS?

Established for over 3 years BCS is well known for the quality of its products and services.

WE HAVE THOUSANDS OF SATISFIED CUSTOMERS ACROSS THE UK.

Fast and efficient delivery service provided. All products sold carry 1 year minimum guarantee. All products UK spec only. All prices include VAT. DONT DELAY ORDER TODAY. CALL IN OR SEND CHEQUES/POSTAL ORDERS TO

BCS LTD

349 DITCHLING ROAD, BRIGHTON, EAST SUSSEX BN1 6JJ

ADD £4 P&P UNLESS STATED. ADD £10 FOR NEXT DAY DELIVERY (MON-FRI) (UK MAINLAND ONLY)

ORDER HOTLINE 0273 506269/0831 279084

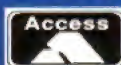

All offers subject to availability. E&OE. Prices/pack details may change without notice.



Due to currency fluctuations, all prices may change without notice - Please call for latest prices.



After *Monkey Island 2*, the Amiga world has waited with bated breath for the next adventure from LucasArts. Indy's back, and this time he's brought SCUMM with him...

In the last couple of years LucasArts have made rather a good name for themselves with their graphical adventure games, ever since the success of *Loom*, followed by *The Secret of Monkey Island* and then the awesome sequel *Monkey Island 2*. Following on from the runaway success of the latter game, they have taken SCUMM and iMUSE (the story and music systems from *Monkey Island 2*) and applied it to a film licence.

"Film licence!", I hear you cry. Well, yes – not all of them have to be disks worthy of

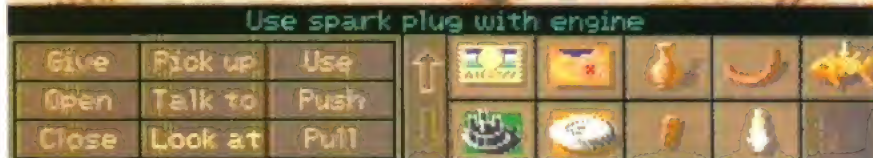

"She may be beautiful but she doesn't know a thing about internal-combustion engines." The lovely Sophia watches Indy fix the wheels. We don't want to give any clues away here, of course...

Indiana Jones and the Fate of Atlantis

AMIGA FORMAT

72

FEBRUARY 1993

nothing better than reformatting. For one thing, it's not really a licence, because there isn't actually a film that it's based on – Lucasfilm enjoyed doing the previous *Indy* games so much, they thought they would make up a plot for another one. And though previous *Indy* games were less impressive, this is just what you would expect from LucasArts.

iMUSE-ing storyline

The game begins with a classy film-style introduction and then a bizarre rendition of the *Indy* theme tune plays in the strange-but-excellent iMUSE system. While this goes on Indy makes his way down through several levels of an abandoned college, trying to locate a missing statue. You control Indy at this point, but you don't have to solve anything just yet.

The reason he's after the statue is that it contains a small bead made from a special metal, which can be used in a similar way to Plutonium. If this bead gets into the wrong hands, a bomb might be made which could level out the odd country or two.



Indy isn't as thick as his macho features make out – a square peg in a round hole is no match for him...

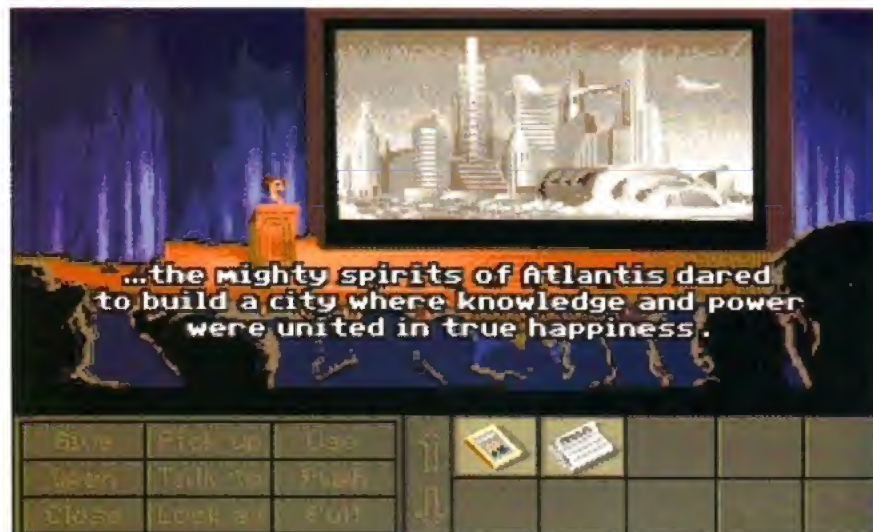

Atlantis or Metropolis? Sophia, world-renowned psychic, explorer and old flame of Indiana Jones, draws a large crowd for her speech about Atlantis...



When the game proper starts, the similarity to *Monkey Island 2* becomes apparent straight-away. Because the same story system is used, the screen layout is very similar, and the same keys are used throughout. This is a good thing, however, because the original system was great to use, and *Monkey Island 2* players will feel instantly at home.

One addition to the story system is the fist-fight. Several manoeuvres are available should you get into a scrap, and these are operated via the mouse or keypad – if your Amiga has a keypad, that is. If the idea of fistfighting doesn't appeal to you don't worry, because you can take three different paths through the story and only one of them has you constantly bashing your way through the adventure.

Each path involves different actions on your part, and meeting different people, but all three paths have the same ultimate goal – to reach the lost continent of Atlantis. The first is the 'Team' path, where you team up with the lovely Sophia, ex-colleague turned psychic, and combine your skills to reach the end. At some points during the game you will need to control Sophia herself, and the inventory display automatically switches to Sophia's possessions – another great touch.

The next path is 'Wits', which is where you must use all your intellectual powers (not humour) to overcome various puzzles during the game. The final one is 'Fists' where – yes, you guessed it – you must rough your way around the world, fighting your way out of



Nudged on by Indy, Sophia gets her come-uppance in Algiers on the wrong end of a knife-throwing act. Our hero, not wanting to cause trouble, looks on quietly.

troublesome situations. The paths do cross at various points during the game, in true time-line style, so even if you choose the Wits path you will sometimes need to fistfight; or if you plump for Fists you will occasionally need to use a bit of nouse.

Action adventure

Whatever path you choose, a huge variety of scenes and challenges await you. These are sometimes funny, sometimes frustrating, but never, ever dull.

The puzzles are very well thought-out, with some exquisite, subtle elements that give you a real kick when you solve them. Also, some action elements are mixed in with the adventure, such as controlling a balloon across a desert, and guiding a submarine through murky waters. Those of you who are horrified by the thought of arcade scenes in your adventures, don't be – they are few and far between, and merely serve as a break from the puzzles.

The story is littered with elements that are genuinely funny, far more than just being there to break up the monotony – check out the scene at the hotel in Monte Carlo where Madame Sophia is holding a seance. The lights have suddenly gone out, and you must make yourself into a ghost by using a bed-sheet, a scary mask and a flashlight. The ensuing scene is nothing short of hilarious, one of those points when you're really glad that you bought the game. We didn't feel, though,



A typical arcade sequence from Indy – keep the balloon away from the ground and fly south...

that it was a good idea to include a picture of the scene here – it would spoil the surprise for those of you who will play it.

There's no doubt about it. LucasArts have done it again. *Fate of Atlantis* is a huge, stunning graphical adventure based on the already tried-and-tested SCUMM format. The story is imaginative, the puzzles are well-constructed, and the gameplay is smooth and slick. As with all multi-disk graphical adventures, it's necessary to swap disks constantly when playing from floppy disk. This is unfortunate, but it shouldn't put you off the game, and it's yet another good reason for saving up to buy that hard drive you've been promising yourself.

If any criticism were to be made it would probably be that the storyline is quite linear, in that each puzzle must be completed before moving on to the next. This is noticeable here because we were spoiled with *Monkey Island 2* and its highly non-linear approach. It's a minor point, anyway, and shouldn't put you off buying what is one of the best Amiga adventures ever.

Andy Nuttall

“ It's imaginative, well constructed and the gameplay is smooth and slick ”

Indiana Jones US Gold ■ £37.99

- Despite being a film licence – of sorts – this is a brilliant adventure game.
- A tried-and-trusted formula, applied to a likeable and humorous theme.
- Stunning graphics describe some beautiful scenes from all around the world.
- Three modes of play, which offer a different challenge depending on your point of view.
- Well thought-out puzzles that give you a real buzz when you've solved them.



92%

REDISCOVER ALL THE GREAT BATTLES OF THE SECOND WORLD WAR WITH 15 NEW MAPS FOR THE WARGAME OF THE DECADE !

THE PERFECT GENERAL

Scenario Disk

**World War II
Battle Set**

Guadalcanal
Omaha Beach
Pegasus Bridge
Sicily
Kasserine Pass
Gafsa
Iwo-Jima
Kharkov
Anzio
Utah Beach
Okinawa
Saipan
Gazala-Bir Hacheim
Arnheim
Oahu

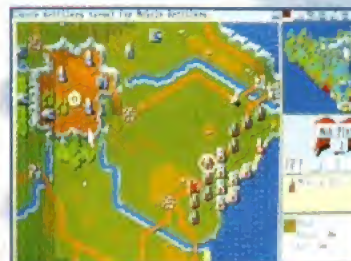

Screen shots on IBM PC



UBI SOFT UK Ltd.
Finchley House 707 High Road
North Finchley London N12 0BT
Tel : 081 343 9055

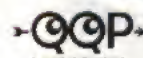

● POWER TO SEE THE PROBLEM ●



● AND SUPPLY THE SOLUTION ●

ACS Electronics is an established service centre for AMIGA equipment. We specialise only in the repair and maintenance of computer hardware. Dedicated to a programme of quality customer care, our continual expansion enables us to offer you, our customer, a service that we believe to be second to none. Our service includes;

FAST EFFICIENT SERVICE,
most repairs are carried out within **ONE DAY**

QUOTATIONS RATHER THAN FIXED PRICES,
fairer to you, and in practice faster to process. Each repair is quoted for separately, no fixed charges full of exclusions, or hidden extras.

REPAIRS FROM £23

FREE CARRIER SERVICE with insurance,
FREE diagnostic inspection, free 90 day warranty, FREE soak test, FREE software.
No hidden charges.

OPTIONAL EXTENDED WARRANTY
at competitive rates.

Experienced and qualified engineering and support staff.

5% DISCOUNT
available to students and OAP's.

UNBELIEVEABLE UPGRADE FITTED PRICE OF £15 INCLUSIVE

Trade and Education welcome. Dealer pack available on request.



COMPUTER MAINTENANCE, UPGRADES AND REPAIRS
B.E.C. ELDON STREET, SOUTH SHIELDS, TYNE & WEAR, NE33 5JE
TEL. (091) 4554300 FAX (091) 455 1847



ICE COOL GAMES IN STOCK

**PLUS HARDWARE &
SERIOUS SOFTWARE**

OVER 4000 pd disks in stock at £1.50 or less per disk

**AGAMIC COMPUTERS
9 CROWN PARADE
CROWN LANE
MORDEN, SURREY
SM4 5DA
Tel: 081-542-7662**

**RING FOR MAIL ORDER
Tel: 081-545-0809**



Programmers

Could you have coded Wordsworth?

Digita are seeking an experienced Amiga programmer to join the in-house Amiga team for 1993 product development.

You'll need to be thoroughly proficient in C and familiar with the Amiga.

Send a full CV and a disk containing some sample code in strictest confidence to: The Secretary, Digita International Ltd, FREEPOST, Exmouth EX8 2YZ

 **DIGITA
INTERNATIONAL**

GASTEINER

Unit 3
Millmead Business Centre
Millmead Road
London N17 9QU
Tel: 081 365 1151
Fax: 081 885 1953



ICD POWER



256 Greyscale Scanners

Total solution for scanning A4 images

**Amiga
Shopper best
buy**



Features: True greyscales, 100-400 dpi, 105mm head, OCR option

Top quality hardware with the latest version of software from Migraph. Allows real time scanning, provides powerful editing/painting features. Compatible (imports/exports) IFF,IMG,PCX,TIFF and MACPAINT formats. Compatible with all Amiga's A500,A500+,A600,A1500,A2000,A2500 and A3000

Touch UP and Merge It Software

Full OCR Version
Software Available
£165.00

£119.95

Touch UP, Merge It and Special
OCR software.

Minimum system requirement 2Mb RAM, and a Hard
Disk

£199.00

Trackballs



Stylish three button trackballs,
with third button supporting
auto fire and drag and hold

**GOLD
AWARD
WINNER
IN ST
FORMAT
92%**

**ST
REVIEW
91%**

With two colour
shining Crystal Ball

£29.95

£34.95

Auto Mouse/ Jostick Switch



St Format 78%
Automatic Switcher
between two input devices
with a click of a button.
E.g. mouse/mouse,
mouse/joystick, joystick/
joystick.

£12.95

Mega Mouse



A 290 dpi high resolution Opto-Mechanical Mouse.
Top quality construction ensures rapid and smooth
movement, with micro switch buttons.

**GOLD
AWARD
WINNER
IN AMIGA
FORMAT
90%**

Mouse only

Mouse with hard mat
and mouse holder

£10.95

£14.95

Optical Mouse



St Format 81%
Cu Amiga 79%
Superb 300dpi Optical
Mouse with effortless micro
switch buttons. Fast, smooth
and reliable.

Includes Optical Mouse Pad
and Holder

£26.00

Optical Pen Mouse



A stylish Pen Mouse with
quality construction and
smooth fast movement.
Micro switch buttons. Ideal
for DTPartwork, etc

Includes Optical Pad

£35.95

Cordless Infrared Mouse



Cu Amiga 81%
Remote control mouse,
long working distance.
Long life rechargeable
battery. 260 dpi.

Includes Hard Mouse Mat.

£45.00



GoldenImage Mouse
with Mat

£ 13.95

Golden Image Optical Mouse
£23.95

**GOLD
AWARD
WINNER
IN AMIGA
FORMAT
90%**

**NEW Golden Image/Gasteiner
Mk II 400dpi made in Japan
MOUSE..... £14.95**

Computers

Amiga 600 £329.99
Amiga 600 2Mb £379.00
Amiga 1200 £379.00

Hard Drive for 600/1200

65Mb 2½" IDE HD £210.00
80Mb 2½" IDE HD £310.00
120Mb 2½" IDE HD £400.00
IDE Cable £10.00

Hard Drives

A500/A500+

40 Mb RAM Upgradeable up to 8 meg £259.00
85 Mb RAM Upgradeable up to 8 meg £329.00
120 Mb RAM Upgradeable up to 8 meg £349.00

A1500/A2000

40 Mb RAM Upgradeable up to 8 meg £249.00
85 Mb RAM Upgradeable up to 8 meg £319.00
120 Mb RAM Upgradeable up to 8 meg £339.00

1Mb RAM with Clock A600	£ 49.00
1Mb RAM without clock A600	£ 45.00
512k RAM with clock A500	£ 25.00
1Mb RAM for A500+	£ 39.00
Kickstart Switch	£ 14.95
Bootslector Switch	£ 9.95
Power Supply for A500	£ 34.95
3.5" External Drive	£ 49.00
1Mb Simms	£ 25.00
2-8 Mb RAM for A2000/A1500	£129.00
Power Scanner	£ 95.00

Please add £3.50 postage and packing to all orders under £100.00 and Orders over £100.00 add £5.00 postage and packing. COURIER CHARGE £10.00. All prices include VAT.
Gasteiner accepts payments by Visa, Access, Cheque or postal order.

E. & O. E. Prices subject to change without notice. Goods subject to availability. Specification subject to change without notice.



It's a matter of timing, and if you get your timing wrong, there are plenty of perils to bring you to a squelchy, tomato-ketchupy end. Almost certain death awaits Terry tomato, as the heavy weight hurtles downwards.



Bill's Tomato Game

If you were a tomato, and you fell off the back of a lorry (no, I mean you really fell from the back of a moving, heavy-goods vehicle) the best you could really hope for is to become low-salt ketchup. At least if you were a conventional tomato, that is. Terry and Tracy are no ordinary tomatoes though. They are the hero/heroine of this new puzzler from Psygnosis. Our Tom and Trace simply bounce down the road in a manner more befitting those little 25p dayglo balls you get in bargain stores. Until the appearance of one Sammy Squirrel that is. By now you will have realised that alliteration is the order of the day, in this sickeningly cute scene-setting story.

But Simon, sorry Sammy, abducts Tamara, sorry Tracy and Timothy, sorry Terry has to rescue her. Not only is this a preposterous premise (see, even I'm getting the hang of it now) for a puzzle game, but it's completely irrelevant too. All I can say for the entire intro to *Bill's Tomato Game* is that it's best avoided. Problem is that you can't. No amount of mouse clicking or joystick fire-button pressing will cut short this tedious tale.

Tedious intro

AH! Some action at last, once the nicely animated, but tedious intro is over it's time to Play *Bill's Excellent Tomato Game*. Did I say excellent? Well it is. Psygnosis put out many games in the course of the year, most of them



Just dodge the sucker gun bullets, bounce on the trampolines and get across the screen, what could be simpler? Erm... lots of things?

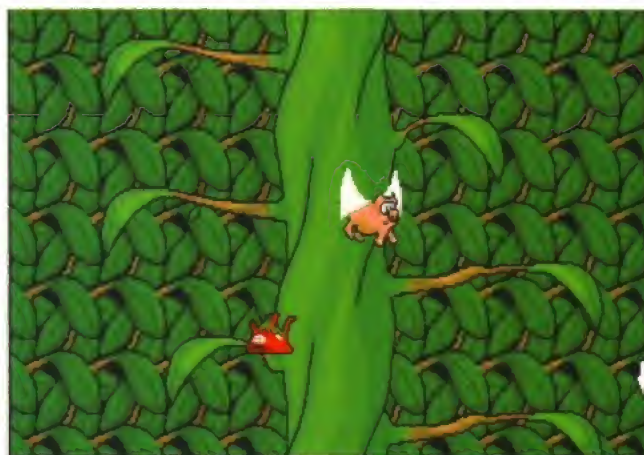

All the levels are reached by climbing the magic beanstalk, the creatures you meet on the way don't exactly help your ascent.

are solid, but uninspiring. But when Psygnosis put out a puzzle game around Christmas, it's time for every lover of Psygnosis puzzle games that come out around Christmas to sit up and play close attention. Just look at their track record. In 1990 there was *Lemmings*, in 1991 there was *Oh No! More Lemmings*, and now in 1992 there is *Lemmings 2* and *Bill's Tomato Game*. You can bet it's more fun than lots of things that are less fun than it...

So Steve Squirrel has nicked your bird, and you have to rescue her. It's terrible how these computer games reinforce macho sexual stereotyping isn't it? The rescue involves climbing this kind of magic beanstalk plant that Sigmund Squirrel lives up. Along the way you are required to tackle various screens that require you to get from side A (the left) to side B (the right). Sounds simple doesn't it? But the clever coders at Psygnosis have put various obstacles in your way. And the only way to avoid these hardships is to strategically place various 'props' around the screen.

These props are the ludicrously alliterative frumulous (?) fan, the tomato trampoline, Jeremy jack in the box and the blocking box. Once you launch Trevor he interacts with these 'props' in a manner that can either facilitate his traversing of the screen or lead him to complete liquidation. The choice is yours.

Lucky escape

The game escapes the problems of the usual set-it-up-and-let-em-go puzzle games by letting you stop Terry in his tracks and set him off again with a simple click of the mouse button. Indeed some screens actually require you to send an initial tomato salvo, let him trigger a switch, then send another to complete the screen.

A time limit decides your success on each screen and until this is exceeded you have an inexhaustible supply of tomatoes. Which is for the better really, because some of these screens are not quite as easy as they might be, in fact some of them are complete sons of female dogs. Altogether, Psygnosis have managed to do something original once again. There's no chance of this ever being as successful as *Lemmings*, but for many an hour of taxing distraction, you couldn't do much better than this.

Marcus Dyson

Bill's Tomato Game
Psygnosis ■ £25.99

- The intro is nicely animated, but ultimately unnecessary and tedious.
- Superb puzzles start simply enough, but steadily become brain-trashingly difficult.
- Free Heinz tomato ketchup, comes in handy when you visit the burger bar.
- Original gameplay concept makes for hours of pure puzzling.

Verdict **88%**

Super Super Heroes Compo

Psygnosis celebrate the impending Super Heroes game with a fantastic competition.

Next month sees the release of *Super Heroes*, a beat-em-up with a difference from Psygnosis. The difference is that before you do battle in this game you get to construct your own superhero. You can do good and fight for God, Justice and the American way with a range of super powers of your own choosing. And with all the options on offer it's possible to create more than 800,000,000 men of steel, which is more than Marvel and DC ever did, both put together.

Have you ever wondered how they do those special effects in the superhero films and television programs? If you have, Psygnosis are offering you the chance to find out. The lucky (and knowledgeable) winner will get a family ticket to the Granada TV Studios, Five super hero videos and a copy of the *Super Heroes* game, all courtesy of Psygnosis. Fourteen lucky runners-up will win copies of the game too.

All you need to do is know Lex Luthers from Luther Vandross' and you could scoop yourself a fantastic prize. As you know, every superhero has an alter ego, a disguise they use when they go to do the shopping at Sainsbury's, or down the local launderette. All you need to do is tell us which superheroes go by the names below. And look out for a full review of *Super Heroes* from Psygnosis soon in *Amiga Format*.

THE QUESTIONS

Name the super hero equivalents of these mere mortals:

- 1 Clark Kent
- 2 Bruce Wayne
- 3 Reed Richards

THE RULES

Same as always: we can't enter, our relatives can't enter, and anyone we've told the answers to can't enter. Batman and Superman can't enter either, so that leaves you. Enter now.

THE ADDRESS

Once you've remembered the answers, scrawl them on a postcard and send them to:

Is it a Bird? Is it a plane? No it's the *Amiga Format Super Heroes* compo.
Amiga Format
 30 Monmouth Street
 Bath
 Avon, BA1 2BW



Meanwhile back at the lab... *Super Heroes* gives you the chance to choose your own super powers, it's a lot less risky than being bitten by a radio-active spider.



Once you've built your ideal super hero, it's time to go out and schlock it to some street trash. Don't try this at home, it really is a bit anti social.

PROFESSIONAL FOOTBALL MASTERS

Football Masters is the very latest Multi-Manager Football Simulator for 16 bit computers. After 5 years of development we are proud to announce the release of the most comprehensive football management game ever. This is the fourth and final revision. It's waiting to test your skills right now! Features Include:-

- Multi-Manager game for 1 to 4 Players. Three levels of difficulty. **48 Hour Dispatch Available**
- Choose six from fifteen **Tactics**. The player **Formation** routine is the most versatile ever created. You can inspect nearly all **Opponents Statistics** and you can see all **Pitch Sizes**.
- Match highlights minute by minute, make substitutions or team changes at any time. Live injuries, yellow/red cards and named goalscorers. **Match Report** with possession, number of shots etc.
- Full UK and European Cup itinerary. Includes FA, League, Zenith Data, Autoglass, European, Cup Winners and UEFA Cups. All cup match rules have been made as accurate as possible. Two leg ties, Extra time, Away goal rule, Seeded draws, **European Mini Leagues**, etc. You can physical participate in any **Penalty Shootout**, fully animated graphics, controlled by joystick and/or mouse. All 4 league divisions (**includes Premier**) with play-offs and league expulsion.
- Real initial, surname, league career records, height and age entered for all players as at the start of the 92/93 Season. Seven skill ratings per player, separate ones for goalkeepers. Plus 15 other special attributes like Captain, Super Subs & Mobility. Players **Preferred Foot**.
- A lively and real-time transfer market, with an approach facility, negotiate wages and contracts. Includes **Foreign Transactions**. Plus loans, free transfers and trainees. Unique and simple training system to improve player skills. ST 512K version excludes penalty sequence.
- High quality printer facilities to list all the vital information. Masses of historical statistics on past games, players and manager. Realistic **Gate Capacities** and **Ground Improvements**.
- Quick game data load and save. All screens updated quickly and displayed in a pleasant format, which is easy to use and comfortable to read. Fully mouse operated. Printed instruction booklet with plenty of diagrams. An Editor is available (as an extra) to add flexibility to the new or saved games.
- An options screen allows some of the above to be switched off if so desired. Others not mentioned above include **Show All Goalscorers** (when possible) and **Show Transfer News**

NEW ENHANCED 92/93 VERSION



WANTED! Sports related programs or programmers.

Bold text highlights new features. Scottish version also available.

There are many, many other little things that make this game the most addictive and accurate interpretation of a Football Managers season. It would be impossible to list all the features in this advert but we assure you that this is the best. We have thousands of satisfied customers from our previous edition of this game, many are still playing it 2 years after purchase. See the order form below for details on how to order this incredible game. Available for all Atari ST's and Amiga's. PC WINDOWS version coming soon. © 1992

WRESTLING MASTERS STABLE MASTERS

An amazing graphical strategic simulator that's fun and easy to play for all the family. 0, 1 or 2 players on keyboard, mouse or joystick. Pick your moves from the selection available and watch your animated warrior battle it out. Watch the energy bar indicators and plan your next move. Edit Wrestlers plus many other features.

Four years of development by a racing expert has led to the release of this great strategy Horse Racing simulation. You can participate as the Owner, Trainer and or Betting Punter in this remarkable game. As the trainer you must try to discover the horses ideal racing conditions (mainly distance & going). Animated race display, formbook, 200 horses with independent personal profiles, tipsters, simple mouse and icon menu selection. Many other items are included.

Amiga 1MB RAM. Only £19.95 Amiga 1MB or any Atari ST. Only £19.95

24 HOUR CREDIT CARD HOT-LINE

(0702) 600557 Answer Phone Outside Office Hours
 FAX (0702) 613747

MAIL ORDERS

All the programs detailed in this advert are only available through direct mail from ESP Software.

Name Address
 Postcode Tel

I have an computer, please send me the following items:-

Quantity	Description (English or Scottish) *	Unit Cost	Total
	Professional Football Masters 512K (ST Only) *	19.95	
	Professional Football Masters 1MB *	24.95	
	P.F.M. Editor (Not For 512K Amiga) *	12.00	
	Wrestling Masters (Amiga 1MB)	19.95	
	Stable Masters (Amiga 1MB or Any ST)	19.95	
	Amiga 512K RAM Expansion	27.00	
	POSTAGE (Non UK Only)	1.00	
	GRAND TOTAL		

If you have a cheque guarantee card or credit card please write its number on the reverse of your cheque, doing so will ensure dispatch within 48 hours of receipt.

I enclose a Cheque/Postal Order made payable to ESP SOFTWARE.

Cut out and post this form to: (photocopies or written orders are acceptable) E. & O.E.

ESP Software (AF), 32a Southchurch Road, Southend-on-Sea, Essex SS1 2ND, UK.

GOT A MEGA DRIVE? THEN GET THIS!

Got a Mega Drive? Then you'll want solid information on which games to buy, all the latest news from around the world, and (basically) a mag that's every bit as good as your console. MEGA (Britain's best-selling Mega Drive mag) kicks in on Thursday 21 January with:

- Over 300 Mega Drive games tips
- The exclusive review of *Afterburner 3* on the Mega CD
- The all-time Mega Drive Top 100 cart chart
- A four-page review of the Mega Drive's best driving game
- Mega Drive and Mega CD news from Japan, USA and Europe
- The chance to WIN! a Mega Drive game a week for a year

No Mega Drive player is fully equipped without it.

WARNING!

Also read five TRUE stories from people who claim their console ruined their lives!

**ON
SALE**
Thursday 21
January

MEGA

100% PURE SEGA MEGA DRIVE...

HISTORYLINE



1914-1918



HISTORYLINE 1914-1918 is a strategy war game simulation set in the period of the first world war.

One or two players are able to take control of opposing forces. Choose to take the role of either the Allies or the German-Austro-Hungarian army. From your aerial view, witness the battle as you deploy and then the enemy counters.

Changing seasons, varying quality of terrain, strategically held locations, and well planned attacks by outmanoeuvring your opponent are all critical considerations to be met in order to achieve victory.

HISTORYLINE 1914-1918 contains a wealth of historical and technical information. This is not only illustrated beautifully on the screen during the course of the game, but is also available for your reference in the extensive and meticulously researched manual.

Making it easy to learn and to play, HISTORYLINE 1914-1918 is a must for everyone interested in an extremely high quality, massively challenging, addictive, and hugely accurate strategy war game simulation.

Hours of enjoyment - *Guaranteed*. You may even learn something!



Screen shots show MS-DOS VGA version. MS-DOS version supports Adlib, Soundblaster, and VGA 256 colour mode graphics. Amiga version supports accelerator boards and 64 colour mode graphics.

Designed and developed by the same team who created Battle Isle.
For further information please telephone 0727-868005

Blue
Byte

Blue Byte / Play Byte
Aktienstraße 62
4330 Mülheim-Ruhr
Germany

TECHNOMANIA



Featuring ...

TECHNOSOUND Turbo

BRITAIN'S No1 Sound Sampling System
"EVERY AMIGA OWNER SHOULD HAVE IT" - Amiga Format

ONLY **£27.99** NORMAL RRP **£39.99** **SAVE £12**



- ROMBO**
- RGB Colour Splitter****£39.99** **SAVE £40**
- Take 2 Animation**.....**£34.99** **SAVE £65**
- POWER**
- Hand Scanner V2.0****£94.99**
- Itsa Mouse****£12.99**

ORDER FORM

PLEASE SEND ME

Name

Address

I ENCLOSE CHEQUE/PO FOR

FIRECREST DISTRIBUTION
P.O. Box 39,
ABERGAVENTY, GWENT NP7 6XL.
TEL (0873) 850028

Please phone for complete price list.

**ADD £2.00
PER ITEM
P&P**



ONLY THE BEST COMPUTER SOFTWARE

If you do not see a title you require ring for 30% off RRP

HIGHLY RECOMMENDED AFG - AMIGA FORMAT GOLD	
Adams Family	16.99
AH37 Thunderhawk (AFG)	30.99
Air Land and Sea (AFG)	22.99
B.A.T. (AFG)	16.49
Battle Command (AFG)	16.99
Battle Isle (AFG)	19.99
Carl Lewis Challenge	16.99
Championship Manager	16.49
Chuck Rock (AFG)	16.99
Civilization (AFG)	22.99
Crazy Cars 3 (AFG)	16.99
Dune	20.99
Dynablaster (AFG)	20.99
España Games	19.99
Eye of the Beholder 2 (AFG)	23.99
F15 - Strike Eagle 2 (AFG)	22.99
F19 - Stealth Fighter (AFG)	19.99
Fire and Ice (AFG)	16.99
Formula 1 GPBX (AFG)	22.99
Graham Taylor Soccer	16.99
Hook	16.99
JW Whirlwind Snooker (AFG)	19.99
Jaguar XJ220	16.99
J. Madden American Football (AFG)	16.99
Kick Off 2 (AFG)	12.99
Laser Squad (AFG)	12.99
Links (AFG)	24.99
Lure of the Temptress (AFG)	20.99
Megalomania - First Samurai (AFG)	20.99
Night + Magic 3 (AFG)	26.99
PGA Tour Golf (AFG)	19.99
Populous 2 (AFG)	29.99
Railroad Tycoon (AFG)	22.99
Robocod (AFG)	16.99
Secret of Monkey Island 2 (AFG)	24.99
Sensible Soccer (AFG)	16.99
Sinicity + Populous (AFG)	19.99
Space Crusade (AFG)	16.99
Wizard (AFG)	16.99
World Series Cricket	20.99
Cool World	16.99
Cliffon	11.99
Dart Attack	21.99
Dark Queen of Kyrin	16.99
Doodlebug	19.99
Fascination	16.99
Free DC	call
Frontier Elite 2	call
Gunslip 2000	22.99
Hero Quest 2	call
History Line	19.99
Human	19.99
Indiana Jones Fate of Atlantis	16.00
Joe and Mac	call
KGB	call
Kick Off 3	call
Krusty Fun House	call
Legends of Kyrandia	23.99
Legends of Valour	call
Lemmings 2 (Oh no not more)	16.99
Lethal Weapon	16.00
Liverpool	16.00
Nick Faldo Golf	call
Nicky Boom	call
Nigel Mansell	19.99
No Greater Glory	call
No Second Prize	16.99
Raiden 2	19.99
Pinball Fantasies (AFG)	19.99
Piracy	call
Populous - The Challenge Games	9.99
Premier Manager	16.99
Premier	16.99
Rampart	16.99
Reach for the Stars	call
Road Rash	16.99
Score Team	16.99
Scrabble	call
Second Samurai	call
Sensible Soccer '93	16.99
Shadow Worlds	16.99
Shadow of the Beast 2	19.99
Shuttle	22.99
Sim Earth	26.99
Streetfighter 2	16.40
Triv Sinelab	16.40
Traders	16.99
Treasures of the Savage Frontier	21.99
Trodders	16.99
Universal Monsters	call
WWF Wrestle 2	16.99
Wizer	19.49
Zool (AFG)	16.99
Zyconix	16.40

TEL: 0272 401315/401316

MON-FRI 9.30am-6.30pm SAT+SUN TIMES VARY, Answerphone at all other times



O.T.B. COMPUTER SOFTWARE

7 CLEEVE WOOD RD, DOWNEND, BRISTOL BS16 2SF
All prices include VAT. UK postage add £1.00. Access and Visa accepted.
Please allow 7 days for cheques.



THE ICING ON THE CAKE

Fit a GENUINE PREMIER MICROS QUALITY "Control Centre" to your Amiga A500/A600/A1200. Atari ST/ Falcon./ Acorn A3010 and transform your "Tasty" computer into something really SPECIAL.



AMIGA A600 "CONTROL CENTRE"

PREMIER MICROS CENTRE consoles are stocked and sold by all good computer retailers.

- MODULES CAN BE PURCHASED SEPARATELY AND ARE THEREFORE EXPANDABLE
- INTERNAL SHELVES FOR PERIPHERALS
- TAILOR-MADE FOR EACH MAKE/MODEL OF COMPUTER
- HIGH QUALITY FINISH, COLOUR MATCHED TO EACH COMPUTER
- LITTLE OR NO WEIGHT TRANSFER TO THE COMPUTER
- THOUSANDS OF SATISFIED CUSTOMERS WORLDWIDE

PREMIER MICROS... THE NAME FOR QUALITY PRODUCTS AT PRICES YOU CAN AFFORD...

Beware of Imitations..... Our "Control Centre" is the the original and still by far the best.

Tel: (0480) 300738 Fax: (0480) 495077

ALL TRADE ENQUIRIES WELCOME

Reach the top with.....

LCL Self-Tuition Courses

NATIONAL CURRICULUM

World leaders • Hons graduate/teacher authors • In educational software charts. • Excellent reviews. (e.g. *Definitely a first class package* AMIGA SHOPPER) • £5 off total for 2, £10 off for 3.

INCREDIBLE VALUE: 24-PROGRAM COURSES WITH A BOOK & MANUAL FOR ONLY £24 EACH (Micro Series have outstandingly good graphics & music for that level)

Totally comprehensive courses with far too many features & topics to list, but some examples are:

MICRO SCIENCE (8 years - GCSE)

NEW

Physics & Chemistry practical experiments • Biology demonstrations • Graphics adventure game

MICRO MATHS (11 years - GCSE)

GCSE CHART-TOPPER

Algebra • Geometry • Trigonometry • Statistics • Arithmetic

MICRO FRENCH (Beginners - GCSE)

ST. F "Best Buy"

Real speech • Graphics adventure game • Talking cartoon

MICRO GERMAN (Beginners - GCSE & Business)

Real speech • Graphics adventure game • Business letter generator

MICRO ENGLISH (8 years - GCSE)

Spelling • Punctuation • Grammar • Literature

PRIMARY MATHS COURSE (3-12 years)

In ATARI Fam. C.

Tables • + - x ÷ • HTU • Long & short multiplication • Fractions

READING WRITING COURSE (3-12 years)

NEW ENLARGED

Alphabet • Handwriting • Creative writing • Reading • Spelling

MEGA MATHS (A level course)

Calculus • Algebra • Geometry • Full-screen graphs

ALL AMIGAs EVEN A1200

(*All appropriate LCL Courses are National Curriculum compatible & run on most computers.)
Send cheques/P.O.s (+99p P&P) or phone orders, or requests for free colour poster/catalogues to:

LCL (DEPT AMF), THAMES HOUSE, 73 BLANDY ROAD, HENLEY-ON-THAMES, OXON RG9 1QB



or ring 0491 579345 (24 hrs)





POST HASTE

ALL PRICES INCLUDE VAT & DELIVERY TO YOUR DOOR

Select any 3 titles valued £7.99 or less and you pay only £20

SOFTWARE
Some of the following games titles are limited offers at the time of going to press. Order early to avoid disappointment. We stock all the latest and currently available titles which we offer at **30% OFF** Recommended Retail Prices

GAMES

1st Division Manager	8.99
4D Sports Driving	7.99
4 Wheel Drive Compilation	9.99
Afterburner	6.99
Allen Breed 92	8.99
Armalyte	7.99
Awesome (Psychosis)	7.99
Bard's Tale III	7.99
Batman the Movie	8.99
Battlehawks 1042	10.99
Battle Squadron	7.99
BattleTech	7.99
Betrayer	8.99
Britzkrieg (1 Mb)	9.99
Brat	7.99
Bubble Bobble	6.99
Budekan	8.99
Captain Dynamo	8.99
Captain Fizz (Psychosis)	6.99
Captive	7.99
Carrier Command	7.99
Centurion Defender of Rome	9.99
Champions Compilation	7.99
Chase HQ	8.99
Classic 4	8.99
Colossus Chess X	8.99
Conqueror	8.99
Corporation - Missions	8.99
Crazy Cars 2	9.99
Deluxe Strip Poker 2	9.99
Dizzy Panic	6.99
Double Dragon	7.99
Double Dragon II	7.99
Dragons of Flame	7.99
F18 Combat Pilot	7.99
Falcon	9.99
Fantasy World Dizzy	6.99
Final Blow	7.99
Flight of the Intruder	10.99
Filmb'o's Quest	7.99
Football Crazy Compilation	12.99
Future Wars	9.99
Ghosts 'n' Ghosts	8.99
Golden Axe	7.99
Head Over Heels	6.99
Impossible	6.99
Indy Heat	7.99
Indy Jones - Last Crusade Action	8.99
Indy Jones - Last Crusade Gr Adv	10.99
International Karate -	6.99
Jack Nicklaus Golf	6.99
James Pond	6.99
Jet Set Willy II	7.99
Keef The Thief	7.99
KickOff 2 Europe data	6.99
KickOff 2 Giants of Europe data	6.99
KickOff 2 Winning Tactics data	6.99
Killing Game Show (Psychosis)	7.99
Kwik Snax	6.99

Last Ninja 3	7.99
Line of Fire	7.99
Lombard RAC Rally	8.99
Lotus Esprit Turbo Challenge	7.99
Magic Fly	8.99
Magic Garden	7.99
Magicaland Dizzy	6.99
Manchester United	7.99
Manic Mirror	7.99
Megafortress	9.99
Midnight Resistance	6.99
Midwinter	9.99
Moonstone	9.99
Navy Seals	7.99
New Zealand Story	8.99
Ninja Warriors	7.99
North & South	8.99
Obitus (Psychosis)	7.99

SUPER SEGA
Golden Axe
Super Monaco G.P.
Shinobi
Crack Down
Eswat
only £9.99

Operation Thunderbolt	6.99
Pacland	7.99
Pacmania	7.99
Pang	6.99
Paperboy	6.99
PKFIGHTER	6.99
Populous	8.99
Populous Promised Lands	4.99
Prince of Persia	5.99
Pro Tennis Tour	6.99
R-Type	6.99
Rainbow Islands	6.99
Rick Dangerous	6.99
Robocop	6.99
Robocop II	6.99
Roadland	7.99
Rugby World Cup	7.99
Shadow Dancer	7.99
Shadow Warriors	6.99
Shoot'em Up Construction Kit	6.99
Slightly Magic	6.99
Shy Spy	6.99
Spellbound Dizzy	6.99
Spike in Transylvania	6.99
Spirit of Excalibur	9.99
Stunt Car Racer	8.99
Super Cars 2	7.99
Super Monaco GP	6.99
Super Saga	6.99
Super Seymour to Hollywood	6.99
Super Smash TV	6.99
Swix	6.99
Test Drive II	6.99
The Break (Tennis)	7.99
Topki	7.99
Total Recall	6.99
Toyota Celica GT Rally	6.99
Treasure Island Dizzy	4.99
Trivial Pursuit	6.99
Turbo Outrun	6.99
Turrican	6.99
Turrican II	6.99
Turtles 2 The Coin Op	9.99
Universal Military Simulator 1	7.99
Untouchables	6.99
Viz	6.99
Wetrix	6.99
White Death (1 Mb)	7.99
Winning 5 Compilation	7.99
World Championship Soccer	7.99
World Cricket	6.99
World Soccer Italia 90	7.99
Xenon II	7.99
Z-Out	6.99
Zak McKracken	6.99

BE AMONG THE FIRST TO PLAY!!! PRE-BOOKED SOFTWARE
We accept advanced orders for all forthcoming software titles and your order will be despatched on the day of release. Your credit card will be debited also on the same day as despatch!

EDUCATIONAL

ADI English (11/12 or 12/13)	16.99
ADI English (13/14 or 14/15)	16.99
ADI French (11/12 or 12/13)	16.99
ADI French (13/14 or 14/15)	16.99
ADI Maths (11/12 or 12/13)	16.99
ADI Maths (13/14 or 14/15)	16.99
Answerback Junior	14.49
Answerback Senior	13.99
Arithmetic (Answerback data)	7.49
Spelling (Answerback data)	7.49
Better Maths (12-16)	16.49
Better Spelling (over 8)	16.49
Cave Man	10.99
Calc and Add	10.99
First Letters	8.99
Fraction Goblins	10.99
Fun School 2 (2-8, 8-8, or 8-)	7.99
Fun School 3 (2-5, 5-7, or 7-)	16.99
Fun School 4 (2-5, 5-7, or 7-)	16.99
Henrietta's Book of Spells	16.99
Hooray for Henrietta	15.99
Kids Academy Which Where What	14.99
Kids Academy Shopping Basket	14.99
Kids Academy Akin's Puzzle	14.99
Lets Spell at Home	13.99
Lets Spell at the Shop	13.99
Lets Spell Out and About	13.99
Magic Maths (4-8)	16.49
Magic Storybook (1 Mb)	14.99
Maths Adventure	16.99
Maths Dragons	10.99

SERIOUS

VIDEO & MULTIMEDIA

Photon Video (Cal Animator)	7.99
Deluxe Video III	56.99
Broadcast Titrer 2	174.99
Broadcast Titrer Font Pack	99.99
Broadcast Titrer Font Maker	99.99
AmigaVision	89.99
Hyperbook	49.99
Scale	174.99
Scala 500	74.99
Director II	79.99
TV Text Professional	89.99
TV Show 2	49.99
VideoTitrer 1.5 3D	99.99

WORDPROCESSING

Final Copy	39.99
Final Copy II	59.99
Pengal	34.99
Excellence 3	54.99
Protect 4.2	39.99
Protect 5	59.99
Word Perfect 4.1	159.99
Word 2.0	89.99

SPREADSHEET

ProCalc	99.99
Advantage	79.99
DG Calc	28.99

TOP TITLES SPECIALS

Putty, Lotus 3, Zool, Wizkid, Aquatic Games, Trodders, Catch'em, Fireforce, Assassins, WWF 2, Project X, John Madden's Football, Sensible Soccer 92/93, Fire & Ice, Jaguar XJ220, Pinball Dreams, Pushover, Road Rash, Archer Maclean's Pool **£18.99 EACH**

Shadow of the Beast 3, Street Fighter 2, Campaign, Populous II, Epic, Dynablasters, Ishar, Lure of the Temptress, Castles, Premier, Legend of Kyandia, Shuttle, Dungeon Master & Chaos Strikes Back, Humans, Pinball Fantasies **£18.99 EACH**

Indiana Jones and the Fate of Atlantis, Civilisation, Knights of the Sky, Silent Service II, Microprose Grand Prix, A320 Airbus, Eye of Beholder II, Campaign, Links Golf, Curse of Enchantis..... **£22.99 EACH**

Monkey Island 2, Perfect General..... **£23.99 EACH**

Maths Mania (over 8)

Mega Maths	16.49
Merlin Maths	17.99
Mickeys Crossword Puzzle	17.49
Micro English	17.99
Micro French	17.99
Micro German	17.99
Micro Maths	17.99
Mix & Match	16.99
Noddy's Playtime	16.99
Paint and Create	16.99
Paint Me a Story	16.99
Picture Fractions	10.99
Reasoning With Trolls	10.99
Shapes and Colours	8.99
Sooty's Fun with numbers	13.99
Spellbook	7.99
Spelling Fair	19.99
Telling The Time	10.99
Things to do with Numbers	13.99
Things to do with Words	13.99
Thomas Tank Fun with words	16.49
Three Bears	18.49
Tidy The House	10.99
World Atlas	44.99

DATABASES

Infofile	19.99
Superbase Personal 2	29.99
Superbase Professional 4	199.99

INTEGRATED (W/PS/DB)

Mini Office	37.00
The Works Platinum	59.00
Gold Disk Office	109.00

DTP

PageStream	129.00
Pro Page 3.2	199.00
Pro Draw 2	99.00
Outline Fonts	99.00
Gold Disk Fonts 1-4	34.99
Structured Clip art	39.00
Deluxe Print II	19.00
Eclips	79.99
Preclips	17.99
Pro Vector	158.00
Designworks	79.99
Expert Draw	39.99

CAD

X-CAD 3D	299.99
X-CAD Professional	149.99

ACCOUNTS

Arena Accounts	79.99
Home Accounts 2	39.99
Cashbook/Final Accounts	44.99
Personal Tax Planner	29.99
Personal Finance Manager - GRAPHICS	27.99

Compendium SIX
Kids type
Weather Watcher
What is it Where is it?
Calendar Quiz
Words & Numbers
Game, Set & Match
Only £29.99

Deluxe Paint IV	59.00
Deluxe Paint II	9.99
Deluxe Photolab	34.00
Spectracolor	57.99
Disney Animation Studio	74.99
Real Things Birds	20.49
Real Things Dogs	20.49
Real Things Humans	20.49
Real Things Horses	20.49
Real Things Sea Life	20.49
Real Things Safari	20.49
Profiles	24.00
Turboprint Professional	34.00
The Art Department	49.99
The Art Department Pro 2.00	134.99

MUSIC X Jnr
Excellent MIDI Value at an incredible Mini price.
Only £19.99

MORPH PLUS

Kara Anim Fonts 1, 2 or 3	130.99
Kara Anim Fonts 4 or 5	29.99
Kara Fonts Headlines 1 or 2	49.99
Kara Fonts Sub Headlines	44.99

3D MODELLING & RENDERING

4D-Professional Kit	32.99
4D-Professional	199.99
Expert Draw 4D Jnr	47.99
Expert Draw 4D	84.99
Sculpt Animate 4D	109.99
Vista Professional	69.99
Scenery Generator	37.99
Scenery Animator	59.99
Imagine 2	149.99
3D Professional	349.99
Real 3D Beginners 1.4	119.99
Real 3D Professional/Turbo 1.4	209.99

PROGRAMMING

Amiga Logo	19.99
Easy AMOS	22.99
AMOS Compiler	26.49
AMOS 3D	22.49
AMOS Professional	44.99
Derpac 3	49.99
HiSoft Basic	57.00
HiSoft Basic Extend	14.49
HiSoft Pascal	74.99
GFA Basic 3.5	7.99

MUSIC

Music Mouse	9.99
Stereo Master	29.99
Deluxe Music Const. Set	49.99
MidiMaster Midi I/F	19.99
Music X Jnr	19.99
AudiEngineer Sound/Sampler V300	299.99
Bars & Pipes Professional	99.99
Bars & Pipes Int. Sound Kit	49.99
Bars & Pipes Music Box A	49.99
Bars & Pipes Music Box B	49.99
SuperJam	74.99

MISCELLANEOUS

ARE XX	32.99
BAD Disk Optimiser	34.99
Cross Dos 5	29.99
Dos 2 Dos	39.99
Disk Master II	44.99
FloppyDisk Accelerator Faccti	9.99
GB Route Plus (New Version)	34.99
Icon Paint	8.99
Quarterback 5 HD/DiskBackup	42.99
Quarterback Tools	59.99

HARDWARE

A500 Plus Cartoon Classics	299
A600	299
A800 Wild Weird & Wicked Pack	349
A800HD Epic Pack	479
A1200	379
A1500 Including Monitor	649
A1500 No Monitor	449
A4000	2000
CDTV	379
10% OFF all CDTV software	
GYP A500 80Mb-8MbRAM(0k)	399
GYP A500 120Mb-8MbRAM(0k)	479
GYP SCSI Controller-8Mb(0k)	119
GYP SCSI 90Mb-8MbRAM(0k)	399
GYP SCSI 120Mb-8MbRAM(0k)	429
120Mb Master Bare Hard Drive	359
80Mb to 520Mb Bare hard disks	POA
44Mb Squest Removable H/Disk	299
Camana 3.5" External Drive	55
Zydec 3.5" External Drive	49
A500 3.5" Internal Drive	45
A800 1Mb Upgrade	38
A500 Plus 1Mb upgrade	35
A500 512k Ram Upgrade(no clock)	20
A500 512k Ram Expansion+clock	75
1.5 Mb Ram Expansion	79
Supra 500RX 8Mb RAM (2Mb Pop)	129
Supra 500RX 8Mb RAM (4Mb Pop)	219
Supra 500RX 8Mb RAM (8Mb Pop)	339
GYP A2000/1500 8Mb Ramcard (0k)	89
1 Mbyte Simms	35
256kx4 RAM chips per Mb	25
1Mbx1 DRAM chips per Mb	35
AT-Once PC 286 Emulator	229
Rombo Vidi 12 Pack	89
OpalVision 24bit Graphics	699
Sharp JX100 A6 Col. Scanner	499
Zydec Hand Scanner	99
Power Scanner	99
Genitizer Graphics Tablet	129
Zydec Microswitched Mouse	17
Naksha Mouse-Operation Stealth	23
Itsa Mouse (Microswitched)	12
Mouse Mat	3
50 Blank Disks	25

MONITORS

Philips 8833-II (UK Model)	219
Commodore 1084/1085A	199
Commodore 1050 Multisync	499
NEC 4FG	519

PRINTERS

(Inc. leads-Amiga Printer Drivers)	
Star L C200 Colour	199
Star L C24-20 Mono	199
Star L C24-200 Colour	299
Starstrip Postscript Laser	1099
Citizen Swift 6 Colour	179
Citizen Swift 240 Colour	299
Citizen Swift 200 Colour	229
Canon Bubblejet Portable	219
HP Deskjet 550C Colour	529

NEW* Opal Vision *NEW
Stunning low cost 24 bit graphics card with future additions to give many of the Toaster functions such as the quad input switcher, genlock/framegrabber, Roaster Chip for digital video effects and scan rate converter. A must for Desktop Video or high quality graphics.
Superb value at only £699

You name it... We do it... Just phone and we'll quote... We are faster and cheaper!
PRICES QUOTED ARE SUBJECT TO AVAILABILITY.. SOME OFFERS ARE LIMITED SO ORDER EARLY TO AVOID DISAPPOINTMENT

Cheques/PO Orders to **POST HASTE**, 11a Burgate Lane, Canterbury, Kent. CT1 2HH
TELEPHONE HOTLINE 0227-764204 9.30am to 7.00pm



(Answerphone outside normal hours)
VISA, MASTERCARD and EUROCARD orders welcome
Visa, Mastercard, Eurocard and PO Orders are despatched same day!
Please allow up to 4 working days for cheques to clear. Overseas orders add £2.00 postage.

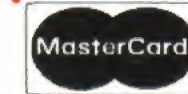

MAIL & TELEPHONE ORDERS ONLY.... NO PERSONAL CALLERS PLEASE!

Did you hear those chattering schoolkids on the bus yesterday? Well this is the game they were all yapping incessantly about. Now it's on Amiga...

This is it, then. The much-vaunted *Streetfighter 2*. The game that, supposedly, everybody's discussing on buses. The game that's causing a generation of Far-Eastern kids to grow up with little joypad-pushing stumps instead of fingers. The game that's giving rise to a rash of children christened Blanka, Dhalsim, Edmund Honda and, worst of all, Ken. And you could be about to subject your Amiga to this.

The idea is simple. You choose one of eight characters, each with different skills and



Some of the moves appear to have little combat value. Honda's gentle knee grab, for example. This induces a drowsy feeling in Dhalsim, who will then let Honda leap up and down on his throat.

Streetfighter 2

AMIGA FORMAT

82

FEBRUARY 1993



These, presumably, are fans of the *Streetfighter* contest who disagree over the relative merits of their fave characters. So they've resorted to settling their dispute in the time-honoured manner of rumbling in a park.

A 1200 VERSION - A FISTFIGHT AWAY

If you've got an A1200, forget it. Forget this version of *Streetfighter 2*, anyway, because it's one of those few games that doesn't work with the machine. But fret, worry and pine not. There's a special A1200 version being written at the

moment. It's been reported as having 256 colours on screen, and the speed of a gazelle with a train to catch.

Streetfighter 2 A1200 version will be covered separately in *Amiga Format*, so watch out for that in the near future.

strengths. You must then fight the others in turn. Obviously you're hoping to punch and kick them to death. If you succeed you get to fight a series of big bosses: beat them and you can rightfully claim to be best in the world.

There are seven skill levels per player, giving a total of 49 possible different combat

ratings for each fight between two contestants. These are the key to the bizarre longevity of *Streetfighter 2*. After a couple of hours practice, you'll be able to beat anybody when your skill is seven and theirs is zero. But working your way up through the levels until you're on zero and they're on seven will drive you mad with frustration.

“ It's the best beat-em-up on Amiga. Get it, get good at it and have a large amount of fun ”

Summer fight city

Each player has his, her or its own special moves. Putting these in was a brilliant touch by Capcom, and it's what makes the game

PAIN AS AN ARTFORM



Chun Li is the fastest fighter of the eight. She's at her best in the air, where she can kick repeatedly, and even stamp on folks' heads. But her most lethal move is the 100-foot kick. This flashes out in front of her, and will cause repeated damage to any fool sad enough to wander into its range. Chun Li's weak point is her stunnability. Two or three good smacks will knock her out, allowing you to give her a serious shoeing.



Ken (and Ryu) can summon the forces of nature into a fireball, which, with a flick of the wrists, can be directed at the opponent. The recipient can either leap over it, block it or take it in the mush. Ken and Ryu also have the Dragon Punch, which protects them from the air. But their weakness is their mid-range. Most of the others can hurt them before Ken and Ryu can get close enough to do any damage back.

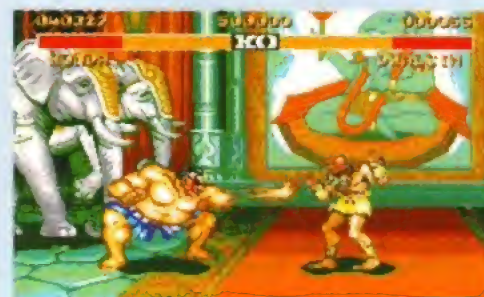

E. Honda is tough, and he's got a wicked 100-hand slap. It's like Chun Li's foot thing, and woe betide any fool who gets in the way. The way to beat Honda is to take to the air and leap on him with a fusillade of kicks. Easily said, but our rubber chum, Dhalsim finds it difficult to bend his un-natural way around E's blubber, which causes all manner of problems. Luckily he can resort to using Yoga Noogies, a humorously vicious form of attack.



Zangief, the Russian meathead, gets a lucky hit on the best character, Blanka – best according to the unofficial AF opinion poll, that is. He's the only non-human, and he's as hard as nails (usually).

great. For example, Ryu and Ken blast firebolts, Blanka electrifies himself and Dhalsim indulges in a harmful spot of yoga flame.

Apart from the specials, each character fights in a different manner anyway. Some are better in the air, some are better at punching and some kick like the very devil. Their relative speeds vary as well. Chun Li is certainly the fastest, but is easily stunned. Zangief is slow but practically unstuntable. Blanka will happily chew your head and E Honda is offensively fat. The game is done in such a way so that every player is about equal overall, but vastly different in their specific characteristics.

Of course, if you like a fair fight, Ken and Ryu are similar. The only difference is that Ken sports blond locks, while Ryu is more of a dark horse, with an attractive headband. When it comes to fighting they're exactly the same. Both can do firebolts and hurricane kicks.

So what about the two-player mode? Well, with a couple of humans behind the joysticks (or Mega Drive joypads – see below), it's the best beat-em-up on the Amiga. The massive



sprites, speed and endless variety all help, but there's something else. Something it's not easy to put your finger on. Something mysterious. (Get on with it – Ed.) An indefinable playability which keeps you and a chum there after the rest of the human race has gone to bed.

There are so many playing styles, techniques and touches that you only pick up once you've been playing a while. Some folk go for

Blanka's over-developed arms have a serious reach. His claws also do a fair bit of damage. But his greatest trick is electrifying himself (which is too unpleasant to show here).

Normally, brawling at American military bases is frowned upon, but in the case of Ken and Ryu, an exception is clearly made. Here, Kenneth cruelly grasps Ryu's hair, and tugs gently,

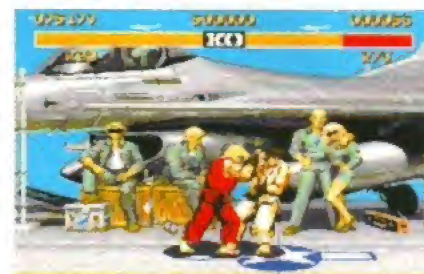

jabbing leg-kicks, others prefer flying punches and aerial assaults. You soon get to know your human opponents' little regular tricks, but it's the swines who vary their approach, drawing you into their lethal range before smacking your tiny head in, who are really annoying.

Does it wok?

Streetfighter 2 is a lot of fun, that much is certain. It looks nice and plays far better than it looks. There's so much in it that you can spend a long time just getting to know what's possible, and what the best moves are against certain attacks. Putting someone diminutive like Chun Li against a large person like Zangief can lead to the most dreadful of battles, with speed versus brawn being the crux.

The only thing wrong with it is that the sprites' huge size makes it a bit jerky at times. It's not too bad, but just enough to be noticeable, and to get a bit annoying after a prolonged playing session. People whiz around the screen very quickly, but there don't seem to be many updates as they do so.

So it only occasionally looks magic, the way they fly around. It's not a big point, but it does mean that *Streetfighter 2* doesn't quite earn a *Format Gold*. It's certainly the best fighting game on Amiga, and no mistake. Get it, get good at it and have a large amount of two-player fun.

James Leach

WILL YOU EVER REACH THE END EITHER?



This is the device they use for playing *Streetfighter 2* on Nintendo, you'll notice it has more buttons, but fear not...

The Super Nintendo (whatever that is) has six buttons, as well as the directional control. Three buttons control the kicking (soft, medium and hard) and likewise, the other three control the punches.

The Amiga doesn't have this number of irritating clicky things on its joysticks, so how are the multitude of moves reproduced? Punches are done by pressing the fire-button, or moving towards the enemy and pressing fire, but kicks are controlled by pushing away from the enemy and hitting fire.



...you won't have any problems playing with a joystick, because of some astute Amiga programming.

It works much better than you'd think and is only a problem for those who are used to playing the Super Nintendo version. So it isn't a problem for us normal folk at all, really.

If you want, though, you can even kick your kid brother off his Mega Drive and use the joypads from that. Now, of course, you get two fire-buttons; one for punching and one for kicking. It is better than a joystick, but if you swap between the equipment too much your playing skills will suffer.

The characters in all their glory, spread out over the world. Each has a story which explains why they're taking part in the *Streetfighter 2* contest. But these are far too crap to go into detail here.

Streetfighter 2
US Gold ■ £25.99

- Very impressive graphics. Great backdrops and massive sprites.
- Wide variety of players and skill-levels, with some seriously good opponents later in the one-player game.
- Lots of moves, blocks, counters and combat skills make the game different every time you play.
- Slightly jerky in places, which keeps the speed up but detracts from the gameplay.



87%

BRITAIN'S BIGGEST SUPER NINTENDO MAGAZINE

Here at *Super Play* we've been flooded with letters in the few short months since our launch. It's no surprise, really – after all, the Super Nintendo is the best console in the world at the moment. It's no great shock that people should come to *Super Play* for their info, either – after all, where else is there to go for such a wealth of Super Nintendo news, reviews, previews and player's guides, every month?

So, to all of you who've caught on to *Super Play*, welcome aboard. We think you'll be glad you joined us. And to everyone else, what are you playing at? If you're even vaguely interested in video games, you must be interested in the Super Nintendo. And if you're into the Super Nintendo, you owe it to yourself to check out *Super Play*. We'll be waiting for you.

£1.95
EVERY MONTH

**JANUARY ISSUE
OUT NOW**

February issue out
7 January



In the January issue:

- Complete guide to the Super Nintendo CD ROM!
- The world's best *Super Mario World* tips
- Future Entertainment Show giant report
- Complete guide to the Super Scope light gun
- Christmas Super Nintendo shopping guide
- *Zelda III* player's guide
- First UK Super NES reader awards
- And reviews of:
 - Mickey's Magical Quest*
 - Super Double Dragon*
 - Super Aleste*
 - Spiderman & The X-Men*
 - Cosmo Gang*
 - Kick Off*
- And many more!

And coming in February:

- The secrets of the new Super NES chips revealed!
- Our first report from Japan!
- And reviews of:
 - NHLPA Hockey*
 - Human Grand Prix*
 - Desert Strike*
 - Volleyball! Twin*
- And many more!

**Don't miss
out on a single
thing!**



**Because the world's best games
machine deserves the world's
best games magazine.**

FREE! ZOO!



SOFTWARE PACK
WHEN YOU BUY AN AMIGA
FROM SILICA



TOTAL VALUE OVER **£265**

Silica are pleased to offer THE Software Pack of the Year FREE with every Amiga purchased at normal Silica prices. It includes the sensational new title ZOO!, which has received rave reviews as the most original game ever seen on the Amiga.

ZOO! - "Knocks the socks off Sonic." - 97% - Amiga Computng - Nov '92
STRIKER - "Footballer of the Year - and no mistake." - 94% - CU Amiga - June '92
PINBALL DREAMS - "It's quite simply superb" - 94% - AU - Sept '92
TRANSWRITE - Premier word processor (UK version) with a 90K spell checker.

Plus, with every Amiga from Silica, we will give you Photon Paint 2 paint package and GFA Basic programming language. A total of over £265 worth of free gifts.

ZOO! PACK:

- ZOO! - platform title of the year £25.95
- STRIKER - soccer simulation £25.95
- PINBALL DREAMS - pinball simulation £25.95
- TRANSWRITE - word processor £48.95

PLUS!

- GFA BASIC v3.5 - programming language £50.00
- PHOTON PAINT 2 - paint package £69.95

£267.87

NEW! AMIGA 1200



- Motorola 68020C Processor
- 14 19MHz Clock Speed
- 32-bit Architecture
- 2Mb Chip RAM Standard
- Amiga DOS v3.0
- AA Chip Set for Enhanced Graphics
- 16 Million Colour palette
- 2-256 Colours on Screen
- 1 x 32-Bit CPU-RAM Expansion Slot
- PCMCIA Smart Card Slot takes 512K - 4Mb PC Cards
- Built-in TV Modulator
- 96 Key keyboard with Numeric Keypad
- 2K* Internal Hard Drive Optional Extra
- 1 Year On-site Maintenance

£399
INC VAT - Ref: AMC 1200

INCLUDES BUILT-IN 18-KEY NUMERIC KEYPAD

NEW! AMIGA 600 PACKS

WILD, WEIRD & WICKED EPIC 'HARD DRIVE' PACK



The Wild, The Weird and The Wicked (WWW) is the title of Commodore's new Amiga 600 games pack. Priced at £349, it comes complete with Amiga 600 computer and mouse, plus a range of high quality entertainment software. For pack contents, plus a list of the FREE gifts from Silica with every Amiga 600, see the chart on the right.

£349
INC VAT - Ref: AMC 0549

For the more serious user, the £499 Epic Language Pack is based around the A600HD, the A600 with 20Mb hard drive. It includes challenging adventure games and software for the linguistically minded! Details are shown on the chart on the right along with a list of the FREE gifts from Silica with every Amiga 600 purchased.

£499
INC VAT - Ref: AMC 0559

AMIGA 600



The new Amiga 600 uses state-of-the-art surface mount technology, for maximum reliability and features a 3 1/2" floppy drive, mouse, TV modulator and smart card slot all as standard. The innovative smart card slot accepts games, ROM or RAM cards (from 1Mb up to 4Mb) and will take advantage of many future new developments. The very latest version of the operating system, Kickstart/Workbench v2.05 is used in the Amiga 600 and its enhanced chip set facilities include improved graphics resolution, increased graphics support and the facility for up to 2Mb of chip memory. The Amiga 600 is fully compatible with the A670 CD-ROM Drive and Interface which will give it access to a full range of CDTV titles and audio CDs. The Amiga 600 is available from Silica in several configurations including a special 2Mb RAM upgrade optional extra - see the chart below.

with **FREE!**
LEMMINGS
AND
DELUXE PAINT III

PLUS! **FREE!**
PACK + MORE! - SEE ABOVE

A600 + LEMMINGS + DPAINT III
£299
INC VAT - Ref: AMC 0666

NEW LOW PRICE!

AMIGA 500 Plus CARTOON CLASSICS



- PACK INCLUDES:**
- THE AMIGA 500 PLUS £299.99
 - BUILT-IN 16 DRIVE FREE
 - AGO TV MODULATOR FREE
 - THE BARONS £24.99
 - CAPTAIN PLANET & THE PLANETEERS £29.99
 - LEMMINGS £29.99
 - DELUXE PAINT 3 £79.99
- PLUS! FREE FROM SILICA**
- ZOO! PACK £127.92
 - PHOTON PAINT 2 £69.95
 - GFA BASIC v3.5 £50.00
- PACK VALUE: 1994.82
 PACK SAVING: 1545.82
SILICA PRICE: £279.99

We are pleased to offer the original 1Mb Amiga 500 Plus (Kickstart/Workbench v2.04), including a built-in 16-key numeric keypad and Cartoon Classics software at a new low price of £279 (previous Silica Price £299). The Amiga 500 Plus can be upgraded, using any of the hundreds of peripherals that are now available, which include the award winning range of GVP hard drives, GVP peripherals can also provide PC emulation, additional RAM expansion, processor acceleration and extra hard drive storage space. There is also a wide range of expansions which give the A500 Plus higher resolutions and more colour and locking capabilities.

INCLUDES BUILT-IN 18-KEY NUMERIC KEYPAD
£279
INC VAT - Ref: AMC 0592

AMIGA 600 COMPUTER OPTIONS

- THE AMIGA 600 + MOUSE, 3 1/2" Disk Drive, TV Modulator, Smart Card Slot
 - 20Mb HARD DISK - Very fast, mass storage for programs and data
 - DELUXE PAINT III - Award winning graphics and animation package
 - LEMMINGS - Save the Lemmings as they drop into 100 screens of danger
 - MICROPROSE GRAND PRIX - Racing Sim with all the thrills & spills of the track
 - SILLY PUTTY - The playable arcade game of immense playability
 - PUSH OVER - A game of puzzles. Can G.I. Ant save Colin Curly's Quavers?
 - EPIC - A Sci-fi adventure. Can you guide a space fleet across the solar system?
 - ROME - Your goal is to become Emperor in this role playing adventure
 - MYTH - Can you stop the spread of evil and question the judgements of the gods?
 - TRIVIAL PURSUIT (in 3 languages) - The great trivia quiz game for the Amiga
 - WORD PROCESSOR + DICTIONARY (in 3 languages) - For creating documents
 - 1 YEAR ON-SITE WARRANTY - For creating documents
- PLUS! - FREE FROM SILICA**
- ZOO! PACK - Four top Amiga titles - see panel above
 - PHOTON PAINT v2.0 - An art package with numerous features & special effects
 - GFA BASIC INTERPRETER v3.5 - A language for programmers of all levels

	NO HARD DRIVE	20Mb HARD DRIVE
LEMMINGS	£299.99	£299.99
WWW PACK	£299.99	£299.99
EPIC PACK	£299.99	£299.99
	£79.99	£79.99
	£25.99	£25.99
	£24.99	£24.99
	£25.99	£25.99
	£25.99	£25.99
	£29.99	£29.99
	£25.99	£25.99
	£19.99	£19.99
	£29.99	£29.99
	£127.92	£127.92
	£89.95	£89.95
	£50.00	£50.00
TOTAL PACK VALUE:	£673.84	£734.82
LESS PACK SAVING:	£374.84	£385.82
SILICA PRICE:	£299	£349
	£499	£499
2Mb RAM	PRICE OF UPGRADE TO 2Mb RAM WITH BATTERY BACKED CLOCK +£45 (RAM 0610)	+£45 (RAM 0610)

ALL PRICES INCLUDE VAT - DELIVERY IS FREE OF CHARGE IN THE UK MAINLAND

SILICA SYSTEMS OFFER YOU

- **FREE OVERNIGHT DELIVERY:** On all hardware orders shipped in the UK mainland.
- **TECHNICAL SUPPORT HELPLINE:** Team of technical experts at your service.
- **PRICE MATCH:** We normally match competitors on a "Same product - Same price" basis.
- **ESTABLISHED 14 YEARS:** Proven track record in professional computer sales.
- **£12 MILLION TURNOVER (with 60 staff):** Solid, reliable and profitable.
- **BUSINESS + EDUCATION + GOVERNMENT:** Volume discounts available 081-308 0888.
- **SHOWROOMS:** Demonstration and training facilities at our London & Sidcup branches.
- **THE FULL STOCK RANGE:** All of your requirements from one supplier.
- **FREE CATALOGUES:** Will be mailed to you with offers + software and peripheral details.
- **PAYMENT:** Major credit cards, cash, cheque or monthly terms.

Before you decide when to buy your new Amiga computer, we suggest you think very carefully about WHERE you buy it. Consider what it will be like a few months after buying your Amiga, when you may require additional peripherals or software, or help and advice with your new purchase. And, will the company you buy from contact you with details of new products? At Silica Systems, we ensure that you will have nothing to worry about. We have been established for almost 14 years and, with our unrivalled experience and expertise, we can now claim to meet our customers' requirements with an understanding which is second to none. But don't just take our word for it. Complete and return the coupon now for our latest FREE literature and begin to experience the "Silica Systems Service".

MAIL ORDER HOTLINE
081-309 1111

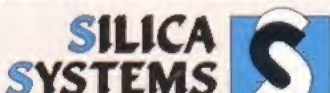

MAIL ORDER: Order Lines Open Mon-Sat 9.00am-6.00pm No Late Night Opening	1-4 The Mews, Hatherley Rd, Sidcup, Kent, DA14 4DX No Late Night Opening	Tel: 081-309 1111 Fax No: 081-308 0660
LONDON SHOP: Opening Hours: Mon-Sat 9.30am-6.00pm No Late Night Opening	52 Tottenham Court Road, London, W1P 0BA No Late Night Opening	Tel: 071-580 4000 Fax No: 071-523 4737
LONDON SHOP: Opening Hours: Mon-Fri 9.30am-7.00pm (Sat close 6.30pm) Late Night Thursday - 8pm	Selfridges (1st Floor), Oxford Street, London, W1A 1AB	Tel: 071-629 1234 Extension 3914
SIDCUP SHOP: Opening Hours: Mon-Sat 9.00am-5.30pm Late Night Friday - 7pm	1-4 The Mews, Hatherley Rd, Sidcup, Kent, DA14 4DX	Tel: 081-302 8811 Fax No: 081-309 0017
ESSEX SHOP: Opening Hours: Mon-Fri 9.30am-5.30pm (Sat 9.00am-6.00pm) No Late Night Opening	Keddies (2nd Floor), High Street, Southend-on-Sea, Essex, SS1 1LA	Tel: 0702 462426 Fax No: 0702 462963

To: Silica Systems, AMFOR-0293-80, 1-4 The Mews, Hatherley Rd, Sidcup, Kent, DA14 4DX

PLEASE SEND A 64 PAGE AMIGA COLOUR CATALOGUE

Mr/Mrs/Miss/Ms _____ Initials: _____ Surname: _____
 Company Name (if applicable): _____
 Address: _____

Postcode: _____
 Tel (Home): _____ Tel (Work): _____

Which computer(s), if any, do you own? _____ **80J**

novatech

BLUEPRINT 1400 DUNDAS SPUR PORTSMOUTH PO3 5RW

DOT MATRIX PRINTERS

All Printers Include Free Amiga Cable

CITIZEN		Ribbon
120D Plus	£111.63	£3.17
SWIFT 9	£170.38	£3.17
SWIFT 200	£186.83	£3.17
SWIFT 240	£239.70	£3.17
SWIFT 240 Colour	£251.45	£14.98

EPSON

LX400	£108.10	£3.35
LX100	£137.48	£5.82
LQ100	£171.55	£5.82
LQ570	£233.83	£3.58

NEC

P20	£198.58	£4.43
P30	£274.95	£4.43

PANASONIC

KX-P1170	£118.68	£4.05
KX-P2180 Mono	£151.58	£8.16
KX-P2180 Colour	£171.55	£16.45
KX-P1123	£151.58	£4.05
KX-P2123 Mono	£171.55	£8.16
KX-P2123 Colour	£203.28	£16.45
KX-P1124i	£203.28	£4.05

SEIKOSHA

SP-1900+	£108.10	£3.23
SL90 24 pin	£148.05	£POA
SL92 +	£198.58	£POA

STAR

LC20	£115.15	£2.76
LC100 COLOUR	£149.23	£11.45
LC24-100	£172.73	£3.40
LC200 COLOUR	£169.20	£11.45
LC24-20	£185.65	£3.40
LC24-200	£199.75	£3.40
LC24-200 COLOUR	£238.53	£13.22

INKJET PRINTERS

CANON

BJ10ex (Black or White)	£191.53
BJ10ex Sheet Feed (Black or White)	£51.70
BJ10ex Battery Pack	£41.13
BJ20 (Black or White)	£289.05
BJC800 Colour	£1523.98

CITIZEN PROJET

£339.58

HEWLETT PACKARD

DESKJET 500	£297.28
DESKJET 500 Colour	£372.48
DESKJET 550 Colour	£481.75
FX80 CART (500 Mono Only)	£61.10
256K RAM CART	£124.55
3YR ON-SITE MAINT.	£57.58

STAR

STAR SJ48	£190.35
SHEET FEEDER	£51.70
BATTERY PACK	£41.13

Ink Cartridges

	1+	6+		1+	6+
CANON			HEWLETT PACKARD		
BJ10E/BJ20	17.33	16.39	PAINTJET BLACK	24.68	22.33
			PAINTJET COLOUR	27.03	24.68
HEWLETT PACKARD			OLIVETTI JP350	17.33	16.39
DESKJET/500 INK CART	16.16	15.22	STAR SJ48	17.33	16.39
DESKJET LONG LIFE	22.03	21.09			
DESKJET 500 COLOUR	25.85	22.33			

MONITORS

PHILIPS CM8833/II £212

Including Free Lead+ Lotus Turbo Challenger II
12mths Onsite Maintenance
Please add £8.23 for Carriage

ORDER INFORMATION

Please Note Printer Carriage Charges

CARRIAGE CHARGES

UK MAINLAND NEXT WORKING DAY
Dot Matrix & Inkjet **£8.23**
Price is per Delivery **NOT** per Box
Call for non Mainland & Saturday
Ribbons & Ink Carts Post Free

TERMS & CONDITIONS

PLEASE READ CAREFULLY BEFORE ORDERING
PAYMENT MUST ACCOMPANY ORDER (CWO ONLY)
TELEPHONE CREDIT CARD ORDERS ARE NORMALLY
DESPATCHED SAME DAY PLEASE ALLOW 3 WORKING
DAYS FOR CHECKS TO CLEAR BEFORE DESPATCH
GOODS ARE NOT SUPPLIED ON A TRIAL BASIS IT IS UP TO
YOU TO CHECK SPECIFICATIONS WITH MANUFACTURERS
BEFORE BUYING WE DO NOT GUARANTEE COMPATIBILITY
PRICES & SPECS MAY CHANGE WITHOUT NOTICE E.&O.E



ALL PRICES INCLUDE VAT - JUST ADD CARRIAGE



TEL 0705 664144

SEIKOSHA

- DOT MATRIX
- LASER
- THERMAL

PRINTERS

Silica Systems are pleased to recommend Seikoshas printers to you at LOW PROMOTIONAL PRICES. The Seikoshas range is built to the highest standards, by a company that is used to manufacturing high quality precision products. In fact, you may be wearing one of these products on your wrist, as Seikoshas are part of the massive Seiko/Epson group (with a turnover of £6 billion and 18,000 staff).

When you buy a Seikoshas dot matrix printer from Silica, we will give you a Silica PRINTER STARTER KIT (worth £25.vat = £29.38) FREE OF CHARGE (see panel below). For further information on the Seikoshas range of printers, complete and return the coupon below. Or, if you can't wait to get your hands on a new Seikoshas printer, telephone our mail order hotline, 081-309 1111 to place your order now.

FREE! FROM SILICA

- **DELIVERY** Next day - anywhere in the UK mainland.
- **HELPLINE** Technical helpline during office hours.
- **STARTER KIT** With every Seikoshas dot matrix printer.

ON-SITE WARRANTY

All Seikoshas Dot Matrix Printers come with a 12 month repair warranty included in the price. Silica are now pleased to offer a full one year on-site warranty option with Seikoshas Dot Matrix Printers for only £10.vat extra! In the unlikely event of a problem with your Seikoshas printer, an engineer will visit your home or business within 8 working hours of your call (on-site warranty effective for UK mainland only).

1 YEAR - ONLY £10

DP-108 laser included 1 year on-site warranty. On-site warranty not available with Smart Label printer. (+vat = £11.75) Ref: POS 8195

NEW MODELS - NEW LOW PRICES!

9-PIN 192cps PRINTER

NEW LOW PRICE!



192 CPS 80 COLUMN

- Seikoshas SP-1900 Plus - 9 pin - 80 col
- 192cps Draft, 48cps NLQ
- 1K Printer Buffer + 2 Fonts
- Parallel Interface
- Graphics Resolution: 144x72dpi
- Epson and IBM Emulation
- Auto Sheet Feeder Option
- FREE Silica Printer Starter Kit

PRINTER RRP £155.00
STARTER KIT £25.00

TOTAL VALUE: £180.00
SAVING: £80.01

SILICA PRICE: £99.99

£99.99

+vat = £117.49 Ref: PRI 8195

9-PIN 300cps PRINTER

NEW LOW PRICE!



300 CPS 80 COLUMN

- Seikoshas SP-2400 - 9 pin - 80 col
- 300cps SD, 240cps D, 60cps NLQ
- 21K Printer Buffer + 5 Fonts
- Parallel and Serial Interfaces
- Graphics Resolution: 240x144dpi
- Epson and IBM Emulation
- Optional Auto Sheet Feeder Unit
- FREE Silica Printer Starter Kit

PRINTER RRP £199.00
STARTER KIT £25.00

TOTAL VALUE: £224.00
SAVING: £89.00

SILICA PRICE: £135.00

£135

+vat = £158.63 Ref: PRI 8204

24-PIN 240cps PRINTER

NEW!



240 CPS 80 COLUMN

- Seikoshas SL-90 - 24 pin - 80 col
- 240cps SD, 192cps D, 84cps LQ
- 20K Buffer + 2 Fonts
- Parallel interface • Opt. Font ROM
- Graphics Resolution: 360x360dpi
- Epson Emulation
- Standard Semi Auto Sheet Feeder
- FREE Silica Printer Starter Kit

PRINTER RRP £199.00
STARTER KIT £25.00

TOTAL VALUE: £224.00
SAVING: £89.00

SILICA PRICE: £155.00

£155

+vat = £182.13 Ref: PRI 8290

NOTEBOOK PRINTER

ENTRY-LEVEL LASER

LABEL PRINTER

FREE! STARTER KIT



NEW LOW PRICE!

144 CPS 80 COLUMN

- For IBM PC compatibles only
- Seikoshas LT-20DX - 24 pin - 80 col
- 180cps SD, 144cps Draft, 60cps LQ
- 1K Printer Buffer + 9 Fonts
- Parallel Interface
- Graphics Resolution: 360x180dpi
- Epson and IBM Emulation
- Built-in 50 Sheet Auto Feeder
- FREE Silica Printer Starter Kit

PRINTER RRP £299.00
STARTER KIT £25.00

TOTAL VALUE: £324.00
SAVING: £105.00

SILICA PRICE: £219.00

£219

+vat = £257.35 Ref: PRI 8202



INC 1 YEAR ON-SITE WARRANTY

- QP-104 - 4 Pages per minute
- HP LaserJet LP™ Emulation
- Resolution: 300x300dpi
- 14 Resident Fonts
- Uses Original HP™ Font Cards
- Postscript Emulation Option (Extra)
- Optional IBM, Epson & Diablo Emulation Cartridges
- Centronics Parallel, RS232C/RS422 Serial Interfaces
- 512K RAM - expandable to 2.5Mb
- Flexible paper handling: Standard paper cassette - 100 sheets
- Optional 2nd bin - 300 sheets
- Quiet Operation 46dB(A)

- Compact Design with Straight Paper Path
- Requires CAB 7500 for PC - £9.95 or CAB 7514 for ST/Amiga - £14.95

RRP ~~£689~~ +vat

SILICA PRICE **£499**

+vat = £586.33 Ref: LAS 6004



NEW! 'PLUS' MODELS

The NEW Seikoshas Smart Label Printer Plus range now includes a PC version with both DOS and a 'Windows' driver and an Apple Macintosh model. All are able to mix fonts on the same label and have many other new features. They will provide letter quality address labels, file labels and bar code labels on demand. The Smart Label Printer sits on the desk, working in the background, while your normal desktop printer gets on with the documents. Using memory resident or DA software, the Smart Label Printer Plus is able to produce a label from the screen text of most popular software packages. The Smart Label Printer Plus is supplied complete with a power cord, a serial cable for connecting to your PC, SLIP software, a roll of labels and a 1 year guarantee. The Apple Macintosh version (PRI 8012) is also available at a new low price of £165.vat.

RRP ~~£240~~ +vat

SILICA PRICE **£185**

+vat = £217.38 Ref: PRI 8015



Every Seikoshas dot matrix printer from Silica comes with the Silica Printer Starter Kit, worth £29.38 (£25.vat) completely FREE OF CHARGE. It includes all you need to get up and running with your new printer.

- 3 1/2" Disk with Amiga & ST Printer Drivers
- 1.8 Metre Parallel Printer Cable
- 200 Sheets of Quality Continuous Paper
- 100 Continuous Tractor Feed Address Labels
- 5 Continuous Envelopes on Tractor Feed

Printer owners may order the Silica Kit (ref: KIT 5000) for only £24.38 - £5 off RRP! WORTH £29.38

081192-1415

SILICA SYSTEMS OFFER YOU

- **FREE OVERNIGHT DELIVERY:** On all hardware orders shipped in the UK mainland.
- **TECHNICAL SUPPORT HELPLINE:** Team of technical experts at your service.
- **PRICE MATCH:** We normally match competitors on a "Same product - Same price" basis.
- **ESTABLISHED 14 YEARS:** Proven track record in professional computer sales.
- **£12 MILLION TURNOVER (with 60 staff):** Solid, reliable and profitable.
- **BUSINESS + EDUCATION + GOVERNMENT:** Volume discounts available 081-308 0888.
- **SHOWROOMS:** Demonstration and training facilities at our London & Sidcup branches.
- **THE FULL STOCK RANGE:** All of your requirements from one supplier.
- **FREE CATALOGUES:** Will be mailed to you with offers + software and peripheral details.
- **PAYMENT:** Major credit cards, cash, cheque or monthly terms.

Before you decide when to buy your new printer, we suggest you think to buy very carefully about WHERE you buy it. Consider what it will be like a few months after you have made your purchase, when you may require additional peripherals and accessories, or help and advice. And, will the company you buy from contact you with details of new products? At Silica Systems, we ensure that you will have nothing to worry about. We have been established for almost 14 years and, with our unrivalled experience and expertise, we can now claim to meet our customers' requirements with an understanding which is second to none. But don't just take our word for it. Complete and return the coupon now for our latest FREE literature and begin to experience the "Silica Systems Service".

MAIL ORDER HOTLINE
081-309 1111

SILICA SYSTEMS

MAIL ORDER: Order Lines Open: Mon-Sat 9.00am-6.00pm No Late Night Opening	1-4 The Mews, Hatherley Rd, Sidcup, Kent, DA14 4DX	Tel: 081-309 1111 Fax No: 081-308 0608
LONDON SHOP: Opening Hours: Mon-Sat 9.30am-6.00pm No Late Night Opening	52 Tottenham Court Road, London, W1P 0BA	Tel: 071-580 4000 Fax No: 071-323 4737
LONDON SHOP: Opening Hours: Mon-Fri 9.30am-7.00pm (Sat close 6.30pm) Late Night: Thursday - 8pm	Selfridges (1st Floor), Oxford Street, London, W1A 1AB	Tel: 071-629 1234 Extension: 3914
SIDCUP SHOP: Opening Hours: Mon-Sat 9.00am-5.00pm Late Night: Friday - 7pm	1-4 The Mews, Hatherley Rd, Sidcup, Kent, DA14 4DX	Tel: 081-302 8811 Fax No: 081-309 0017
ESSEX SHOP: Opening Hours: Mon-Fri 9.30am-5.30pm (Sat 9.00am-6.00pm) No Late Night Opening	Keddies (2nd Floor), High Street, Southend-on-Sea, Essex, SS1 1LA	Tel: 0702 462426 Fax No: 0702 462936

To: Silica Systems, AMFOR-0293-84, 1-4 The Mews, Hatherley Rd, Sidcup, Kent, DA14 4DX
PLEASE SEND A BROCHURE ON THE SEIKOSHA RANGE

Mr/Mrs/Miss/Ms: Initials: Surname:

Company Name (if applicable):

Address:

Postcode:

Tel (Home): Tel (Work):

Which computer(s), if any, do you own?



It's all about leading a bunch of rats to their deaths at the hands of a major character from *The Simpsons*, with a hideous Rat-Krunch-Matic machine. What larks. What dead rats. What a great leap from Krusty!



As a clown, Krusty is well aware that the first rule of comedy is timing. So hit that lift now!



There are also laser-firing things that will bap our Krusty at every opportunity. Fun stuff.

AMIGA FORMAT

88

FEBRUARY 1993

Krusty's Super Fun House

Ask any *Simpsons* fan and they will tell you it's not just Bart, Lisa, Homer, Marge and Maggie (the main characters) that make the show worth going to a BSKyB-owning friend's house to watch. It's the subsidiary characters too; people like Itchy 'n' Scratchy, and Krusty the clown.

Well, now there's a game based on the latter character. *Krusty's Super Fun House* is a good-looking, nicely thought-out platform game which should be able to keep the massed of gamers on their toes for a while.

The first point to bear in mind here is that you should not judge the game by the ease of level one – and boy oh boy, is it easy. This is just a test level which gets you acclimatised to the control system and a few of the puzzles and tricks that will assault you in later levels.

In fact, the way in which the levels are set up is nicely thought-out too. You move Krusty about a few platforms, each of which contains a number of doors. Simply stand outside a door, soak in the strangely menacing music, press the fire-button and in you go to one of the sub-levels. Then all you have to do is to play a kind of reverse *Troddlers/Lemmings* in

which you have to lead a bunch of rats to their deaths at the hands of a major *Simpsons* character. Like *Troddlers* you have to make use of

“ A Simpsons spin-off that looks excellent and has some neatly thought out levels too ”

blocks to achieve this aim. Unlike *Troddlers* you have to search for these blocks along your way – and this search becomes more difficult with the later levels.

“Ha ha” said the clown

Killing the rodents is not the end of the level though. Once this is done, you have to search for some power-ups and hidden levels. Once all this is cleared up, you exit the level, and the door is locked behind you. Lock all the doors, and move up a level. “Easy! Ha, ha, ha!” Nope! Even though Krusty can leap twice his height and pick up loads of ammo, you will be foxed by the puzzles that build up and up.



The walls are sweating purple acid drops, the snakes are looking mean.



And Krusty is bog-all good with his Krusto-gun. All looks lost.



No! Krusty comes through with flying colours and then kicks a bag to death.

The game looks excellent, there's some great use of colour and neatly designed levels, but it's let down by strange parallax scrolling and (once again, when will programmers get this right?) poor collision detection. Time and time again we see Krusty hanging off the last pixel of a platform; certainly he does a well-animated wobble as he hangs there, certainly he looks worried, but even more certainly he shouldn't be in the position in the first place.

Despite the moans *Krusty's Super Fun House* is a mightily enjoyable piece of Amiga gameplay. Once you've got over the initial amazement that Krusty himself can outleap Bob Fosbury from a standing start, you will find yourself coming back for more and more.

Tim Smith

Krusty's Super Fun House Accolade ■ £25.99

- Another decent off-shoot of *The Simpsons*!
- The in-game music is distinctly strange, almost worrying, which makes up for the lack of in-game sound effects.
- Graphically it's very, very impressive.
- Don't be fooled by the first level, it's very easy but it's only a teaser.
- Easy control method makes the puzzle-solving on later levels fun to do.



85%



A typical scene from old London. As you wander the darkened streets, you spot a figure in the distance. Is it Jack the Ripper, or are you...?

Waxworks

Accolade ■ £34.99

You're fifth in the long line of twins and you've discovered, after your Uncle's death, that one twin has disappeared at four points in your family's history. Before he died your Uncle made a wax exhibit of the location where the four disappearances occurred, such as Ancient Egypt and 1888 London.

Each exhibit holds the key to a curse on your family, and you must enter into each waxwork and solve the four different mysteries. Each exhibit has excellent graphics, and the locations are viewed in a first-person perspective, 3D style. Interaction with the game's characters and puzzles is similar to that of a role-playing game, with objects to pick up and use and nasties to slay.

Waxworks is packed with atmosphere which is enhanced by wondrous graphics. Some of the scenes are quite gruesome, so think twice before buying it for kids, but for someone who's partial to a bit of schlock-horror it's not bad at all - if a tad overpriced.

Andy Nuttall

Verdict **72%**



Caveman Joe decides to carry out an impromptu dental inspection. Unfortunately Joe ends up being the filling.

Joe and Mac: Caveman Ninja

Elite ■ £24.99

Here's a prehistoric game in which you control one of two cave-men as they trudge their way through danger, chasing the kidnapers of their women-folk, pausing along the way only to club a few dinosaurs to death and adjust their trendy underwear.

Armed only with a trusty set of axes, your cavemen set off fighting their way through 13 levels of colourful, cartoon-style fun, murdering and maiming T-Rexes everywhere they go (and we wonder why dinosaurs became extinct).

With clear graphics and well-drawn backdrops the game almost stands off the screen. Unfortunately the game is a bit shallow, your cavemen amble along and the levels are linear and allow no exploration. These factors reduce the enjoyment value of the game and spoil an otherwise excellent product.

Dave Paget

Verdict **74%**

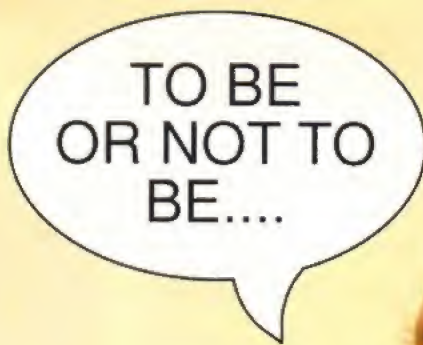

THE NEW ADI JUNIOR. A HEAD START FOR THE UNDER 5s

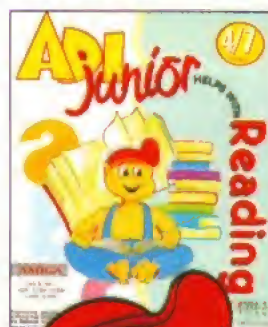

"Hamlet, that. Oh yes. Learn to read at 4½ and not even the Bard is hard. And that's no Winter's tale..."

My Ariel-like buddy Adi Jr. taught me. There I was, sat at the computer, and hey presto! He appears and whisks me off to his magical world packed with word games.

He's always around to help me out - he even sends word back to Mum and Dad and tells them how I'm scoring so they can ask the school to lend a hand.

Adi's such fun to play with. He's the perfect learning tool for any of us - from tender 4 year olds right up to ancient 7 year olds - and everything he teaches fits in with the National Curriculum.

Back to Hamlet. Wonder why he was named after a cigar? Now that really is the question..."



ADI junior

EUROPRESS SOFTWARE

CREATIVE EDUCATION

Europress Software, Europa House, Adlington Park, Macclesfield, SK10 4NP.

TEL: 0625 859333. FAX: 0625 879962.



Since the release of *Leaderboard*, software companies have been striving to produce the ultimate computer golf game. Have *Grandslam* managed a hole in one this time?

Once again, as the great tradition of Amiga golf games continues, we are invited to tread the fairways courtesy of *Grandslam*, the company responsible for games like *Liverpool* and *England Football*. Those titles weren't exactly God's gift to Amiga games, so it came as a surprise to find that *Golf* is pretty good. In fact, it's very good.

Does it give good golf?

So, after *PGA Tour Golf* and *Links*, what can *Grandslam* come up with? The answer is a happy medium. *Links* is slow, but hardened golfers will play it for its sheer realism. *PGA Tour* is faster, but the graphics aren't great – still workable, but not stunning. *Nick Faldo's*



Hooray! Nutts has scored a birdie! It's only on amateur mode, so it still gives you the 'Mulligan' option (so you can cheat by taking your last shot back and trying again), but the feat still stands!

AMIGA FORMAT

90

FEBRUARY 1993

Nick Faldo's Championship Golf

TAKE YOUR SHOT HERE...

When hitting the ball, the white bar travels from left to right. Click once in the wrist snap area to add 10 per cent power to your shot, then double-click in the shot area to hit the ball straight.



Wrist snap area Shot area

IF YOU FIND YOURSELF A BIT TEED OFF...

...simply read through these details to find out how to play.

Click on either of these two arrows to alter your direction by a few degrees.

When you move the mouse over this bar, the extra options pop out.

Select your club by clicking on one of these icons.

Your skill with the selected club is shown by this bar.



Alter the strength of your next shot.

Adjust your stance and the spin of your shot.

Blue lines show the width of the actual screen.

The current lie of your golf ball.

This is the overall wind direction.

A map of each hole is displayed here, with the wind directions.

Faldo Golf is fast and good-looking, although the graphics aren't as good as those in *Links*. Presentation is polished, with plenty of options available via the options screens. These make good use of colour and bas-relief (metallic 3-D effect), and are easy to use.

When playing the full game, there are two courses to choose from, which may be played

using stroke or match-play rules. Space is provided for up to eight human players' names, while eight computer opponents are provided with varying skill levels. You can choose up to four of these 16 players to do the rounds.

Let's play a round

After player selections comes the club selection screen. Each human player must select a number of clubs (up to 13) from those available. A nice touch here is the skill meter next to each club, which shows how good a player is with that club. Although the levels are set randomly at first, they move depending on the player's skill – so if you play well with a 1-iron, the level will gradually rise for 1-iron as each shot is played. These player attributes may be saved along with other match data.

The first thing that hits you is the slick way everything fits together. The screens are easy on the eye – which is good because you don't have to look far to view the map, find your current lie, or any other information.

Once on the first tee, you will notice two shaded bars on the right and left-hand sides of the screen. Moving the pointer into these will bring up the menus. The first is the club selector, where you choose the club you want for your next shot; the second is a small map of the current hole, and all relevant positions of obstacles. Also, you can view the current lie of the ball, and the wind strength and direction.

Depending on the shot, you can adjust your stance to open or closed. This will help



This is the role-playing element of the game. As you play, the better you do with a particular club, the stronger you will be with it in future. Here, you can choose the stronger 13 clubs.

you get more swerve on the ball, or get underneath it for a chip shot. Taking the shot is simple to understand, but difficult to master.

If you selected Amateur play, not only are the clubs easier to use, but after each shot you are given the option of taking the shot again (Mulligan), or moving to the new ball position. This is great for beginners, because you can practice a difficult shot until you get it right.

Having mentioned the uppers, let's look at the downers – but they're only niggly criticisms. The first is that you can't quit from the options screens, so if you make a wrong selection – such as choosing one player instead of two – you have to choose your clubs and go into the game before pressing Escape to return to the original options.

After you've zipped through the options and had a knock-around, you will probably turn to the training mode. This gives you a selection of shots to practice. As you successfully complete each shot you're presented with another, more difficult version – and Nick Faldo himself (well, a crude representation of his head) talks you through.

Although the trainer idea is good, there is one flaw. While Nick explains what you must do to complete the shot, he doesn't actually

advise you on your mistakes. In the putting section, if you miss the hole, he says "Work your shoulders more." Now this doesn't really mean anything for two reasons: one, Nick offers this reply regardless of the direction or strength of your shot, and two, you have no option to "work your shoulders more" anyway.

This applies to the other training modes. A better idea would have been to store a few more phrases which could be used to actually help a player who has made a simple error, such as not correcting his stance or choosing the wrong club.

Finally, the gameplay is limited in that you can't look ahead to the position of your ball, so when you've made your shot you don't really know if it's good or not. This is an oversight, because it would have been simple to display the ball's position on the map.

Faldo, though, is both fun and playable. It's highly competent compared to other top Amiga golf games, it beats them as far as presentation is concerned and it has an excellent multi-player option. Playing a round with your friends has never been more addictive.

Andy Nuttall

" Faldo's presentation beats all other Amiga golf games "

Nick Faldo's Golf Grandslam ■ £34.99

- Brilliantly slick presentation, backing up excellent graphics and good sound effects.
- Current skill levels with particular clubs may be saved to disk, and then reloaded at a later time.
- As quick as *PGA Tour*, with graphics that almost match those of *Links*.



Damn, I lost. I reckon it must be those double-bogeys on the 4th and 10th that did it...

$$E=Mc^2$$



THE NEW ADI JUNIOR. A HEAD START FOR THE UNDER 5s

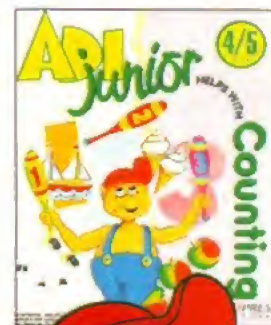

"Cor! Little old me – 4½ if I'm a day – and already a dab hand at this Maths lark...

Of course it's easy peasy thanks to ADI Jnr., my extraterrestrial chum. He's always on hand to help as I toddle through yet another fantastic counting game on the computer.

He even conjures up reports on my scores for Mum and Dad so they can ask the teacher at school to help with my 'weak spots' (what am I, a metal component ?!).

ADI's such fun to play with, he's the perfect learning tool for any of us – from tender 4 year olds right up to big 7 year olds – and everything he teaches fits in with the National Curriculum.

Everyone says I'm a real little Einstein. Me? I just shrug and say it's all relative, isn't it?"



CREATIVE EDUCATION
Europress Software, Europa House, Adlington Park, Macclesfield, SK10 4NP.
TEL: 0625 859333. FAX: 0625 879962

TRIOLOGIC

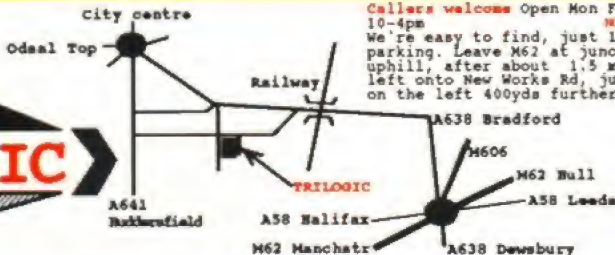

Callers welcome Open Mon-Fri 9am-6pm, Sat 9am-4pm, SUN 10-4pm. **NEW OPEN SATURDAY 10-4pm.** We're easy to find, just 1.5 miles from the M62. Easy parking. Leave M62 at junction 24, take A638 to Bradford, uphill after about 1.5 miles & just past the park, turn left onto New Works Rd, just over a railway bridge. We're on the left 400yds further on opposite a PO mail box.

UNIT 1,
253 NEW WORKS RD,
BRADFORD
BD12 0QP

SALES

0274 69 11 15

FAX 0274 60 01 50

**ACCESS, VISA,
SWITCH, DELTA
CONNECT
AMERICAN
EXPRESS**

**FAST MAILORDER SERVICE
SAME DAY DESPATCH***

ORDERING IS EASY

- 1) Order by phone using your credit, charge, or debit card.
- 2) Order by Mail - sending cheque bankers draft or postal orders made payable to TRILOGIC.
- 3) Please add part postage & packing of £1.00 to small orders under £100 or £2.00 to small orders over £100. Large/heavy items sent overnight only - £5.50. First class Registered post £1.50 upto 1kg.
- 4) Overnight carrier £5.50 extra. UK Mainland only. Scotland Highlands £7.50 extra.

EXPORT ORDERS WELCOME

None EC countries - deduct 15% add carriage. For EC Countries - UK vat (17.5%) must be charged from 1-1-93. Please ask for carriage charges.

BEST PRICE GUARANTEE
SERVICE - at NO EXTRA COST
Our policy is & has been for the last 8 years, to:

- 1) Send orders within 24hrs subject to goods being in stock.
- 2) Endeavour to keep at least 90% of items in stock.
- 3) Only charge prices different from those advertised due to unavoidable manufacturers price increases & to inform you of any change at the time of ordering.
- 4) Offer free advice on any item.

MOUSE & JOYSTICKS

ULTIMATE PRO ANALOGUE JOYSTICK NOW £19.99

Super low cost smooth action Analogue joystick with fire button on the end, plus prestable X & Y trimmers, Microswitch fire buttons; autofire (not all games support autofire) Ideal for flight simulators etc (Not all games support analogue joysticks)

MOUSE / JOYSTICK PORT SWITCH £12.99

- * Has sockets for mouse & joystick.
- * Push button selects mouse or joystick.
- * Uses no power unlike other types.
- * Saves wear & tear on mouse port.

NAKSHA MOUSE + OPERATION MANUAL

OUR PRICE only £24.99
Includes Mouse mat & holder

BUDGET REPLACEMENT MOUSE £14.99

DELTA JA ANALOGUE JOYSTICK	£14.99
PRO 5000 MINI - BLACK	£10.99
ELITE AUTOPIRE	£12.99
SPEEDLINK AUTOPIRE	£11.99
SPEEDLINK ANALOGUE	£11.99
OPTICAL MOUSE	£17.99
MOUSE MAT	£3.99
MOUSE HOLDER	£1.99
JOYSTICK EXTENSION LEAD (3m)	£2.49
PC ANALOGUE JOYSTICK CONVERTER	£7.99

BOOKS & VIDEOS

* DISK INCLUDED WITH THESE BOOKS

AMIGA FOR BEGINNERS	£14.99
AMIGA BASIC INSIDE & OUT	£21.99
C FOR BEGINNERS	£17.95
DISK DRIVES INSIDE & OUT	£27.95
DOS INSIDE & OUT	£22.95
DESKTOP VIDEO	£23.95
GRAPHICS INSIDE & OUT	£31.95
IMAGINE COMPANION	£24.95
LITTLE BLUE WRENCH BK	£14.95
MUSIC ON THE AMIGA	£27.99
OSING AREX ON THE AMIGA	£26.99
OSING DELUXE PAINT	£19.95
UNDERSTANDING IMAGINE 2	£24.95
USER INTERFACE MANUAL	£18.99
HARDWARE REF MANUAL	£21.95
ROM KERNEL REF MANUALS - EACH £28.95	

DIGITISERS, GENLOCKS, SCANNERS & ENHANCERS

ROCCON PLUS NOW ONLY £139.99
A superb value Genlock with overlay & fader controls + RGB pass thru.

HARDY SCANNER £94.99
In our experience, this is by far the best B/W hand scanner in this price bracket. 400dpi, 64 level grey scale + excellent Datascan Professional 2 software.

ROC KEY Chroma keying unit £269.99
The ideal partner for the Roccon Plus. This add-on 'keying' unit enables professional effects such as Chroma keying, luma keying, Key thru, Graphics overlay, key window etc.

VIDE 12	£82.99	NEW Colour Frame grabber/digitiser.
VIDEOMASTER	£59.99	VIDEO & AUDIO DIGITISER IN ONE
HYPERVIDE	£509.99	Frame grabber, colour digitiser & genlock in one unit
COLOURPAC	£409.99	Frame grabber & colour digitiser in one unit.
RENDABLE 9802 GENLOCK	£135.99	Low cost hi-spec budget genlock.
RENDABLE SUPER 9802 SVHS	£493.99	Semiprofessional SVHS Genlock.
		Foreground & background modes! Super VHS input & output! Composite video input & output! hardware controlled fades; colour fade Amiga to video; fade to black; several powerful 'wipes'. VERY GOOD VALUE FOR MONEY!
DCU	£399.99	External graphics enhancer for all Amigas.
VIDEO GARDEN	£129.99	Comprises DIGIVIEW. GOOD video digitiser (the best for use with a camera) + DIGIPOINT 3 + ELAN PERFORMER. SAVE £17.00!
PLECTER PAPER VIDEO 2	£229.99	Fits inside your A500,500+ 1500 or 2000 & eliminates annoying flicker. Latest improved version. Requires VGA or Multisync monitor. Compatible with ALL Amiga video modes. Overscan capability for full screen display. No visible scan lines.
PLECTER PAPER FOR AMIGA1500/2000	£209.99	WITH BUILT IN STEREO AMPLIFIER
EPHOS OF 6000 COLOUR SCANNER	£879.99	PRICE DOWN Professional quality Flat bed colour scanner capable of resolving 16.7 Million colours; or 256 level grey scale. at 300dpi resolution. Includes Amiga driver software.

SPECIAL PRODUCTS

SUPERFI 2 STEREO SYSTEM - HI FI QUALITY 20 WATTECH

We've looked high & low for a **POWERFUL, TOP QUALITY** Stereo speaker system for use with most Computers, keyboards, Stereo VCRs, Satellite Systems & Walkmans. Now we've found one - it is a 20 watt per channel, directly mains powered, 3 way speaker system. It has Bass, treble & volume controls & comes with connecting leads. Frequency response: 12Hz - 20kHz. **ONLY £54.99.**

STFI STEREO SYSTEM - latest model only £32.99

AMIGA ROM SWITCH SIMPLE TO FIT Only £27.99
Our Keyboard operated two way Rom switch enables you to use either of 2 Workbench rooms. To switch over, just hold Down Control/Amiga/Amiga keys until you hear a beep. (Release them before the beep to 'warn start' with the current rom. Fits A500/500+/1500/2000. Fitting invalidates computer warranty unless fitted by us. Fitting charge £15.00 Please state which you have Amiga when ordering.

ROM SWITCH & 1.0 ROM only £54.00 ROM SWITCH & 2.01 ROM only £54.00

5 PORT PRO-MIDI INTERFACE £24.99
Our unique 5 port Midi interface has In, Out, 4 thru sockets plus two additional switchable Out or Thru sockets for ingenious versatility. So you can have 1 In, 1 Out & 3 Thru, or 1 In, 1 Thru & 3 Out, or 1 In, 2 Out & 2 Thru! Fully compatible with all Amiga Midi software, & most keyboards.
Extra Midi leads 1.2m - £1.40 3m - £2.40

STEREO SAMPLER 2 NOW ONLY £34.00

Our Superb sounding STEREO SAMPLER 2 uses an expensive state of the art A/D chip which samples so fast, it captures every detail of the sound. Easily adjusted level control, connecting lead supplied. Fully compatible with all popular sampling software.

FREE STEREO SAMPLING SOFTWARE

AMIGA PRINTER PORT EXPANDERS

FOR USE WITH PRINTERS, SAMPLERS, VIDEO DIGITISERS, SCANNERS ETC
These compact fully Switched Expansion boxes enable you to connect upto four peripherals to your computer. The connectors on the units are the same type as the Computer's printer connector so your peripherals just plug straight in. A connecting lead worth £10.99 - 2m for use with printers only, or 30cm long if used with digitisers, scanners & samplers (state which req'd.) is supplied free, to link the expander to the computer. All 25 connections are switched, ensuring isolation of connected devices.

2way - £24.90 3way - £27.90 4way - £29.90

TWO WAY SCART SWITCH £17.99

This compact switch box converts most Tva & Tv monitors to DUAL SCART INPUT. Thus you can connect your Amiga & your VCR to the one scart socket on your Tv & a push button switch selects input one or input two - ie VCR or computer. RGB, Audio & Video inputs are switched.

DISKS & SPARES

3.5" DISKS (BRANDED IDK OR DYSA) IN BOXES OF 10 WITH LABELS (DS/DD) £7.99
1 boxes for £15.00; 5 for £50; 10 for £55

1.5" DRIVE HEAD CLEANER £3.99

PATTER AGNIS 8172A	£39.99
SUPER DENISE	£39.99
GARY	£15.99
8520A 1/2 CHIP	£129.99
1MBx 9 DISKS	£199.99
4MBx 9 DISKS	£259.99
256KBx4 DRAMS for A550 1meg	£29.99
AMIGA INTERNAL DRIVE	£59.99
MANS SUPPRESSOR BLOCK 4WAY	£12.99
UPGRADED A500 POWER PACK	£44.99
A550 REPLACEMENT PSU	£94.99
GVP REPLACEMENT PSU	£64.99
EXTERNAL DRIVE PSU	£29.99

UPGRADE YOUR AMIGA.
OFFICIAL 1.04 UPGRADE KIT INC 2.04 ROM, WORKBENCH DISKS & FULL RING BOUND MANUALS - £79.99

NEW - WORKBENCH 2.1
WORKBENCH 2.1 UPGRADE for A600 (or 500 with 1.04 Rom) Disks & manuals - £42.99

WORKBENCH 2.1 KIT & 1.04 ROM £74.99

ICKSTART 1.3 ROM £29.99

ICKSTART 2.04 ROM £39.99

AMIGA 500 REPAIR SERVICE
Fixed price repair charge - £49.99 inc part & labour. Excludes Power ank, keyboard & internal drive repair. Free estimate.

DUST COVERS

'REAL A TYPE' TYPE THERO KEYBOARD SKIN
Don't risk spillages - they're guaranteed to 'write off' your Amiga.
Waterproof & moulded to fit snugly over each key, but flexible enough to type thru.

AREX 500, 500+, 1200, 1500 £10.99
State which when ordering please.

ANTISTATIC DUST COVERS

AMIGA 500 & 500 Plus	£3.99
AMIGA 600/600HD/1200	£3.99
AMIGA 1500/2000 2PICK	£12.99
AMIGA 1500/2000 KEYBOARD	£3.99
3.5" EXTERNAL DRIVE	£2.99
8R3 / 1084 MONITOR	£6.99
SWIPT 9, IC200 PRINTER	£6.99
SWIPT 24/LC24-200	£6.99

BACKUP UTILITIES

X COPY PRO NEW £34.99
Latest version - complete with NEW Mk 2 Automatic Cyclone external drive adaptor. Highly successful.

Mk1 CYCLONE ADAPTOR £12.99

AMI SUPERCARD £34.99
(Requires an external drive)

OTHER DISK UTILITIES

ACTION REPLAY 3 FOR A500 ... £54.99

ACTION REPLAY 3 FOR 1500/2000 £64.99

NI. Making backups without the permission of the copyright holder is illegal.

EDUCATIONAL

ADI ENGLISH & MATHS	£18.99
ANSWERBACK QUIZZES	£14.99
BETTER MATHS (12-16)	£19.99
BETTER SPELLING (8-)	£19.99
DATAGOD	£14.99
DIAGNOSIS DISCOVERY KIT	£16.99
FIRST SHAPE (3-8)	£12.99
FIRST LETTERS & WORDS (3-8)	£12.99
FUN SCHOOL RAINZ	£19.99
FUN SCHOOL SPECIALS	£18.99
FRENCH MISTRESS	£16.99
GERMAN MASTER	£16.99
ITALIAN TUTOR	£16.99
JUNIOR TYPIST (5-12)	£19.99
KID'S TYPE	£17.99
KID TALK	£12.99
LETS SPELL SERIES	£16.99
LINKWORD LANGUAGE	£21.99
MAGIC STORY BOOK	£18.99
MATHS TALK (5-13YRS)	£19.99
MATHS TALK PRACTICES	£19.99
MATHS MANIA	£19.99
MATHS ADVENTURE	£19.99
MICRO MATHS	£19.99
MICRO PREACH	£19.99
MICRO ENGLISH	£19.99
MICRO GERMAN	£19.99
MEGA MATHS	£19.99
MONEY MATTERS (4-YRS)	£14.99
NOODY'S PLAYTIME	£19.99
PICTURE BOOK	£16.99
POSSIBLE BOOKS 1 & 2	£16.99
READING WRITING COURSE	£19.99
RHYMING NOTEBOOK	£12.99
SPELL BOOK	£19.99
SPANISH TUTOR	£16.99
TARGET MATHS (4-)	£16.99
TRICKS TO DO WITH... SERIES	£19.99
VOYAGER 1.1	£69.99
WEATHER WATCHER	£17.99
WORLD ATLAS	£41.99

SPECIAL OFFER

EDUCATIONAL COMPENDIUM 4 ... £29.99
Excellent Value boxed set comprising:
* WORDS & NUMBERS * KID'S TYPE
* GAME SET & MATCH * WEATHER WATCHER
* WHAT IS IT WHERE * CLANDESTINE QUIZ
15 IT ?

MIRACLE MUSIC KEYBOARD SYSTEM

"The Piano that teaches you how to play"
Includes 4 octave FULL SIZE Keyboard, 100 Instrument sounds & effects. "Artificial intelligence" software for the Amiga which customises the lessons to each individual.

Our price £270.00 save £20.00

TOP 30 AMIGA GAMES

A320 AIRBDS	£26.99
AIR SUPPORT	£7
ASSASSIN	£18.99
ARCHER MACLEANS POOL	£18.99
BIRDS OF PREY	£25.99
CHAMPIONSHIP MANAGERS	£18.99
CAMPAIN	£24.99
CEASAR	£24.99
CIVILISATION	£24.99
COOL WORLD	£18.99
CRASH CARS III	£18.99
COURSE OF ENCHANTRIA II	£26.99
EYE OF THE BEHOLDER	£18.99
FINAL FLIGHT	£18.99
FIRE & ICE	£18.99
FORMULA 1 GRAND PRIX	£25.99
P15 STRIKE EAGLE II	£25.99
GRAMM TAYLORS SOCCER	£18.99
GOBLIINS	£18.99
MAGAZ THE HORRIBLE	£18.99
HEAD TO HEAD	£
HURANS	£21.99
INTERNATIONAL SPORTS CHALL	£21.99
ISLAND	£19.99
ISLAND JONES & PATR OF ATLANTIS	£18.99
JIMMY WHITE'S SNOKKER	£21.99
LETHA WRAPON	£18.99
LEGEND OF KYRANDIA	£25.99
LEADS UNITED CHAMPIONS	£18.99
LINKS	£24.99
LINKS COURSES	£12.99
LURE OF THE TEMPTRESS	£21.99
JAGUAR XJ220	£18.99
JOHN BARNES FOOTBALL	£18.99
LOTUS TURBO 3	£18.99
MONKEY ISLAND 2	£26.99
ROBERT HANSELLS WORLD CHAMP	£21.99
PGA TOUR GOLF	£21.99
PERFECT GENERAL	£
PINBALL DREAMS	£18.99
PINBALL FANTASIES	£21.99
POPULOUS 2	£19.99
PROJECT X	£18.99
PUSHOVER	£18.99
PUTTY	£18.99
RAMPART	£18.99
RED RISK	£18.99
ROAD BASH	£18.99
ROKROSPORT	£18.99
SABRE TEAM	£18.99
SENSIBLE SOCCER 92/93	£18.99
SILENT SERVICE 2	£25.99
SHADOW OF THE BEAST III	£21.99
STRIKER	£18.99
SHUTTLE	£22.99
SHARD OF HONOUR	£18.99

**TOP AMIGA PROGRAMS
MAJOR PRICE REDUCTIONS**

ALL SOFTWARE UK VERSIONS

ADVANTAGE	£69.99
ADORAGE	£67.99
AMI ALIGNMENT	£42.99
AMIBACK	£44.99
AMAS 2	£69.99
AMOS	£34.99
AMOS - EASY	£22.99
AMOS 3D	£21.99
AMOS COMPILER	£20.99
AMOS PROFESSIONAL - NEW	£49.99
AREX V.1	£34.99
ARY DEPT PRO	£124.99
AUDITION 4	£37.99
AUDIOMASTER 4	£59.99
AUDIO ENGINEER 2	£165.99
BARS & PIPES	£109.99
BARS & PIPES PROFESSIONAL	£224.99
BROADCAST TITLER 2	£169.99
CAN DO V2 NEW VERSION	£99.99
CASHBOOK CONTROL/FINAL A/C/S	£54.99
CROSS DOTS V5 Inc PC emulator	£22.99
DAY BY DAY	£12.99
DELUXE PAINT 4.13	£69.99
DELUXE MESSIC	£49.99
DELUXE VIDEO 3	£69.99
DEVFAC 3 - new version	£51.99
DE CALC	£29.99
DIRECTORY OPSYS	£26.99
DISK MASTER	£39.99
DISK MASTER 2	£49.99
DOS TO DOS	£29.99
E TYPE	£24.99
EXPERT DRAW	£49.99
EXPERT 40 7MR	£25.99
EASY AMOS	£29.99
EXCELLENCE 2	£59.99
EXOTIC CARS FOR IMAGINE	£34.99
EXTENDED C2 LATEST VERSION	£68.99
FLOW V.3.0	£59.99
GE ROUTE PLUS - PRICE DOWN	£42.99
GALLERY - NEW DATABASE	£59.99
GOLD DISK OFFICE 2 NEW	£94.99
GOLD DISK OFFICE PORT PK	£34.99
HIGH SPEED PASCAL	£69.99
HISORT BASIC	£44.99
HOME ACCOUNTS 2	£39.99
HOMERASE	£24.99
HOTLINE	£49.99
HYPERBOOK	£44.99
IMAGINE 2	£199.99
IMAGINE OBJECTS DISK	£84.99
IMAGEMASTER - NEW PRICE	£124.99
INTROCAD PLUS	£74.99
KINDWORDS 3/PRICE DOWN	£39.99
LATTICE C V6 /S/C NEW	£209.99
MACRO 88000 ASSEMBLER	£39.99
MAILSHOT PLUS	£37.99
MASTERWORD	£34.99
MAXIFLAN V4	£89.99
MEDIA SHOW	£51.99
MEGANIX MASTER NEW	£29.99
MIANI OFFICE - BARGAIN	£39.99
NORTH PLUS	£154.99
MUSIC X	£36.99
ORGANISE	£46.99
ON LINE PLATINUM	£34.99
PAGESTAMP 2.2	£125.99
PAGESTREAM FONT PACKS	£41.99
PEN PAL - SPECIAL OFFER	£35.99
PERSONAL TAX PLANNER	£29.99
PERSONAL FINANCE MANAGER	£19.99
PERFECT SOUND	£57.99
PROFESSIONAL CALC	£139.99
PRODATA 1.2	£89.99
PROFESSIONAL DRAW V1	£89.99
PROFESSIONAL PAGE 3	£179.99
PROTEK 5.52	£79.99
PROMOTE V.3.3 - NEW VERSION	£59.99
QUARTERBACK 5	£54.99
QUARTERBACK TOOLS 170 OPP	£39.99
QUARTKIT	£37.99
SARON PUBLISHER £40 OFF	£189.99
SCALE 500	£74.99
SCALE PROFESSIONAL	£199.99
SCULPT 10XL	£109.99
SCULPT ANIMATE 4D JNR	£94.99
SONIX	£34.99
SOONMASTER	£99.99
STEREO MASTER	£29.99
SUPERJAM	£67.99
SUPERPAGE PROF 4 LOW PRICE	£155.99
SUPERPLAN	£69.99
SYSTEM 3e	£54.99
TALK 2	£39.99
TECHNOBOARD	£29.99
TRANSMITE	£28.99
TURBOPRINT PRO V2 NOW ONLY	£35.99
VIDEOMASTER	£59.99
WORDWORTH 2 - NEW VERSION	£79.99
XCAD 2000	£109.99

MORE AMIGA GAMES...

THE MANAGER	£18.99
TRODDERS	£18.99
VIKINGS	£25.99
WARRID	£18.99
WFF WRESTLEMANIA	£18.99

COMPLATIONS

BIG BOX 2 - 16 GAMES	£22.99
CONCERT CLASSICS	£21.99
DREAM TEAM	£18.99
FANTASTIC WORLDS	£26.99
FLIGHT COMMAND	£38.99
FOOTBALL CRAZY	£18.99
INTELLIGENT STRATEGY GAMES	£18.99
LEMMINGS THIN PACK	£32.99
MEGA SPORTS	£18.99
QUEST & GLORY	£22.99
SUPERFIGHTER	

AMIGA 600
'WILD, WEIRD & WICKED' £779.99

AMIGA 600HD
'EPIC' PACK' £779.99

- > MOUSE
- > 1MEG RAM
- > 3.5" DISK DRIVE
- > WORKBENCH 2.04
- > BUILT-IN TV MODULATOR
- PLUS
- > DELUXE PAINT 3
- > GRAND PRIX
- > FISHBOVER
- > PUTTY

ALL 600s HAVE FREE 12 MONTHS ON-SITE WARRANTY

Add £42.99 for 2 meg versions

AMIGA 600 £279.99

- > MOUSE
- > 1MEG RAM
- > 3.5" DISK DRIVE
- > WORKBENCH 2.04
- > BUILT-IN TV MODULATOR

ZOOL PACK. ONLY £19.99 with any Amiga.

* ZOOL	rrp	£25.99
* PINBALL DREAMS	rrp	£25.99
* STRIKER	rrp	£25.99
* TRANWRITE	rrp	£49.99
(Wordprocessor)		
TOTAL VALUE		£127.96

UPGRADE YOUR 600.
WORKBENCH 2.1 UPGRADE £42.99
Similar to Workbench 3 - many new features & utilities. No need to open your Amiga since no new rom chip to install.
2 & 4 MEG FAST MEMORY CARDS IN STOCK
1MEG INTERNAL RAM CARDS IN STOCK
INTERNAL HARD DRIVES FROM UNDER £120
AMIGA 600 DELUXE MONITOR STATION / CONTROL CENTRE £49.99
AMIGA 1200 DELUXE MONITOR STATION / CONTROL CENTRE £49.99
Comprises colour matched steel stand for monitor/tv; shelf under for Psi & external drive etc; Mouse & Joystick port extension cables; mouse holder; mouse mat & large dust cover covers monitor & computer.

STOP PRESS - HURRY - BEAT THE PRICE RISES COMMODORE ANNOUNCE PRICE INCREASES ON ALL AMIGAS FROM 1-1-93

WE WISH ALL OUR CUSTOMERS A HAPPY & PROSPEROUS NEW YEAR

SALES: 0274 - 691115 OPEN SUNDAY

AMIGA 1200

COMMODORE DO IT AGAIN!

ASTOUNDING SPEC:

- 68020 32BIT Cpu
- 14.19MHz CLOCK SPEED
- 2 MEG RAM
- 3.5" FLOPPY DRIVE
- 16MILLION COLOUR CAPABILITY
- BUILT-IN TV MODULATOR
- WORKBENCH 3, MOUSE & PSU
- 32 BIT EXPANSION PORT

FREE ON SITE WARRANTY

PHONE FOR LATEST LOW PRICE STOCKS ARE LIMITED RESERVE YOURS NOW!

INTERNAL HARD DRIVES FOR YOUR AMIGA 600 & 1200.

20MEG:	PRICES	BOOTS UP
40MEG:	FROM	IN LESS
60MEG	UNDER	THAN 10
80MEG	£120	SECONDS
120MEG		

- * Prices include drive cable.
- (Cable also available separately for £9.99)
- * Formatted ready to use.
- * Easy to fit - installs in second - attach to internal drive bay bracket (screws included) & plug-in the cable - that's all there is to it. Fitting charge £15.00

1 & 4 MEG PCM CARDS IN STOCK - PLEASE PHONE FOR PRICE.
32BIT INTERNAL FAST MEMORY CARD FOR A1200 - P.O.A.

The following programs, we believe, already offer enhanced features with the A1200: Wordworth 2; Prowrite 3.3; Pagestream 1.2; Final Copy 2; Art Dript Pro v2; Vhdl 1.2; Imagemaster. Imagine 2, D Paint 4 & Seals est mean.

ALL PRICES INCLUDE VAT

10-4PM
SEE OPPOSITE PAGE FOR 'NEW TO ORDER'

TRILOGIC

NO AMIGA REPAIR BILLS FOR 3 YEARS.

Underwritten by a leading UK insurance Co. ACCIDENTS can happen to anyone - & they aren't covered by the manufacturer's warranty. AND once this has expired, you can bet things will start to go wrong - remember the average minimum Amiga repair cost is £49.99 so it DOES make sense for a one off payment of £42.99, to KNOW that come accident or breakdown - you will never have ANY repair bills to pay for 3 YEARS. This Extended Warranty/Insurance policy must be taken out within 30days of purchase. Full details on request.

IT'S BACK! AMIGA 500 PLUS CARTOON CLASSICS

- > BUILT-IN 3.5" DISK DRIVE
- > 1MEG RAM
- > MOUSE
- > TV MODULATOR
- > WORKBENCH 2.04
- PLUS
- > LEMMING
- > CAPTAIN PLANET
- > THE SDPSONS
- > DELUXE PAINT 3

2Meg version - add just £42.99

£Phone

AMIGA 500 PLUS WORKBENCH 2.1 UPGRADE - MANY FEATURES SIMILAR TO A1200 - £42.99

1.3 AMIGAS WITH 1MEG RAM. PLEASE PHONE FOR DETAILS

EXTERNAL DISK DRIVES

ROCLITE RP382av 3.5" DRIVE
WITH ANTIVIBR & ANTY CLICK FEATURES.
OUR PRICE £67.99
OR WITH NEW ICOPY PRO £99.99

CUMANA CAX354 3.5" DRIVE £56.99
OR WITH NEW ICOPY PRO £89.99

MEMORY UPGRADES

- AMIGA 600 PLUS 1MEG MEMORY UPGRADE £44.99
Just plugs in. No soldering Warranty unaffected.
- A500 / 500+ 1/2meg upgrade without clock £24.99
- A500 / 500+ 1/2meg upgrade with clock & battery £26.99
Just plugs in. No soldering Warranty unaffected.
- AMIGA 600 1meg upgrade - clock (unpopulated) £27.90
- AMIGA 600 1meg upgrade + clock complete - now only £44.99**
Just plugs in. No soldering Warranty unaffected.
- A600/1200 2MEG RAM CARD £149.99
- A600/1200 4MEG RAM CARD £221.99
- DKB MEGACHIP BOARD FOR A1500/2000 1m2meg £184.99
- 1.5 MEG A500 UPGRADE fully populated £69.99
- GVP AMIGA 1500/2000 8 MEG CARD (unpop) £99.99
- 1MEG x9 SIMMS EACH £29.99
- 4MEG x9 SIMMS EACH £99.99
- GVP 4MEG x 32BIT SIMMS EACH £169.99

PRINTERS

CITIZEN SWIFT 9COLOUR ONLY £184.99

Spin printer capable of 192cps draft, 48cps NEO printing speed. Four built-in fonts. Friction & tractor feeds. Paper park - saves having to remove continuous paper when you want to use single sheets. Low cost ribbons. 2 year warranty. Epson & IBM Proprietary emulations. Low noise level.

CITIZEN SWIFT 240C COLOUR £289.99

24 pin printer with 240cps draft & 90 cps letter quality print speed. Nine letter quality fonts, 2 scalable letter quality fonts. Paper parking, push & pull tractor feed, friction feed. Epson LQ570, NEC P20 & IBM Proprietary 24ms emulations. Ultra low noise level. Quiet mode for even lower noise. 2 year warranty. Incredible quality colour graphics.

CITIZEN SWIFT 240 SUPERB NEW MODEL & ONLY £254.99

24 pin printer with 240cps draft & 90 cps letter quality print speed. Nine letter quality fonts, 2 scalable letter quality fonts. Paper parking, push & pull tractor feed, friction feed. Epson LQ570, NEC P20 & IBM Proprietary 24ms emulations. Ultra low noise level. Two year warranty.

CITIZEN PRODOT 24 PROFESSIONAL PRINTER £259.99

24pin 90 Column; 5 fonts; Epson, IBM & Neo emulations; 360x360 dpi graphics printing; 16K buffer. Colour version £299.99

CITIZEN PROJET INKJET LASER QUALITY PRINT £390.00

300dpi Laser quality 50 nozzle Ink jet printer. Fast & very quiet. 360cps draft & 240 cps letter quality print speed. Three letter quality fonts + optional font cards. HP Deskjet Plus emulation. Optional 128K & 256K ram cards. 100 sheet automatic feeder. Ink cartridges - £13.99

BUDGET 4PPM LASER PRINTER - SEKOSHA OP 104 £350.00

Four page per minute; HP Laserjet IIP emulation; 300x300 DPI; 1yr on site warranty. Postscript version with 2meg ram £449.99
THESE PRICES INC VAT.

FREE STARTER PACK WITH ALL CITIZEN PRINTERS. INCLUDES PRINTER CABLE; AMIGA DRIVER DISK & 250 (approx) SHEETS OF PAPER

MONITORS & TV MONITORS

PHILIPS CM883mk2 GOLDSTAR TV MONITOR HI-RES 14" COLOUR MONITOR £229.99

- > 14" SCREEN
- > STEREO SOUND
- > RGB & COMPOSITE INPUTS
- > ON SITE WARRANTY
- > LOTUS TURBO CHALLENGE
- > OFFICIAL UK MODEL
- > DUST COVER £6.99
- > CONNECTING LEAD £3.99
- > OR BOTH FOR £8.99
- > 14" SCREEN
- > FULL REMOTE CONTROL
- > SCART SOCKET (rgb input)
- > SUPERB PICTURE
- > DUST COVER £6.99
- > CONNECTING LEAD £3.99
- > OR BOTH FOR £8.99
- > 14" ANTIGLARE SCREEN
- > 0.28mm DOT PITCH
- > 1024 x 768 PIXELS
- > ANALOGUE RGB INPUT
- > TILT / SWivel BASE
- > FLICKER FIXER COMPATIBLE

CBM 1084s MONITOR - SPECIAL OFFER ONLY £199.99 INC LEADS. TV TUNER - Suitable for use with Philips/ Commodore monitors. £39.99
EXCELLENT PICTURE. BUILT IN SPEAKERS

HARD DRIVES SUPERB GVP HARD DRIVES

- GVP HD8 FOR A500 & 500+ - NO DRIVE £189.99
- GVP SERIES II HD8- 80 Meg for A500 £379.99
- GVP SERIES II HD8- 120meg for A500 - now only £425.99
- GVP SERIES II HD8- 240meg for A500 - now only £699.99
- The HD8 series II can accept either 1 or 2 or 4, 1 meg simms, OR two, 4 meg simms
- GVP SERIES II HD8 for A1500/2000 - NO DRIVE £119.99
- GVP SERIES II HD8+ 80meg for A1500/2000 £334.99
- GVP SERIES II HD8+ 120meg for A1500/2000 - now only £400.99
- GVP SERIES II HD8+ 240meg for A1500/2000 - now only £649.99
- The HC 9 Series II can accept upto 8, 1meg x9 Simms in 2 meg steps.
- A530 528K Hard drive & 68030 Accelerator for A500 £699.99
- A530 120Meg Hard drive & 68030 Accelerator for A500 £784.99
- A530 240Meg Hard drive & 68030 Accelerator for A500 £996.99
- The A530 Combo feature a 68030 40MHz cpu, 1 meg ram expandable to 8meg, 68882 maths co-processor socket, power supply, cooling fan, mini-expansion slot, SCSI hard disk controller & hard disk as specified above. The A530 run at 12MIPS compared to standard Amiga's 0.87MIPS
- GVP 68882 MATHS CO-PROCESSOR KIT for A530 COMBO £209.99
- 1MEG SIMMS FOR GVP DRIVES £29.99
- 4MEG x9 SIMMS FOR GVP DRIVES £79.99
- GVP IMPACT EXTERNAL TWIN 51/4" HARD DRIVE CASE £174.99

ACCELERATORS & EMULATORS

- KCS PC CARDS - PRICES DOWN
- KCS POWER PC CARD v4.5 FOR AMIGA 500 & 500 PLUS £149.99
- MS Dose 4 if required £34.99
- KCS POWER PC EMULATOR CARD FOR AMIGA 600 £89.99
- AMIGA 1500/2000 KCS ADAPTOR £84.99
- VOITEX AT ONCE PLUS 286 PC EMULATOR FOR A500 £219.99
- This is a 16MHz PC card for the Amiga 500, 500+, 1500, 2000, enabling your Amiga to run PC software. No soldering installation, VGA, EGA & CGA PC graphics modes supported, runs as a task on the Amiga, supports hard drive, 80287 socket
- GVP PC286 PC EMULATOR CARD FOR SERIES II HARD DRIVES £169.99
- NO NEED TO OPEN YOUR A500 - plugs into the special slot in the Series II Hard drives. Use a 16MHz 80286 - (upto 15 times faster than original standard IBM PC). Includes 512K ram Emulates CGA, EGA/VGA, Hercules & Mono PC video modes on your Amiga monitor. Compatible with Mdos 3.2 & higher & DRDOS 5 & 6. Reads & writes MSDOS files on the Amiga internal & external floppy drives. Socket for optional 80287 co-processor
- GOLDEN GATE 38461 PC CARD FOR A1500/2000 NEW ONLY £409.99
- ELIZARD TURBO/ MEMORY BOARD FOR A500 /300+ £309.99
- Clock doubled 68000cpu, 8meg ram capacity - upgradeable from 1meg (2, 3, 4, 5, 6, 8 meg steps). Fully autoconfiguring. With only 1meg on board - gives 200% speed increase over standard Amiga.
- GVP G-FORCE AMIGA 1500/2000 ACCELERATORS
- G-FORCE 030 40MHz 68030cpu 40MHz clock £799.99
- G-FORCE 030 50MHz 68030cpu 50MHz clock £1099.99
- HD MOUNTING KIT £39.99

INTERNAL HARD DRIVES FOR YOUR AMIGA 600 & 1200.

20MEG	PRICES	VERY FAST ACCESS TIMES
40MEG	FROM	* Prices include drive cable.
60MEG	UNDER	* Formatted ready to use.
80MEG	£120	* Easy to fit - installs in second - attach to internal drive bay bracket (screws included), plug-in the cable & that's all there is to it.
120MEG		

PRINTER & MONITOR LEADS

- AMP1 1.8m PARALLEL PRINTER LEAD £9.99
- AMP2 3m PARALLEL PRINTER LEAD £12.99
- AMP3 5m PARALLEL PRINTER LEAD £15.99
- MFL 25WAY MALE - FEMALE LEAD 2m LONG £10.99
- MHL 25WAY MALE-MALE LEAD 2m LONG £10.99
- MML 36W MALE-MALE LEAD 2m LONG £12.99
- PRINTER PORT SHORT EXTN 17" LEAD FOR SAMPLERS etc £9.99
- 2 PIECE UNIVERSAL PLASTIC PRINTER STAND £5.99
- UNIVERSAL METAL PRINTER STAND & PAPER HOLDER £10.99
- LACROSS a/adhesive LABELS approx 3.5"x1.5" 1000 for £7.99
- CONTINUOUS 60gm PAPER 11"x9.5" box of 2000for £21.99
- RIBSON RE-INKING SPRAY - Jet black - saves £10 £11.99
- MWB RIBBONS for most Citizen, Panasonic, Star £4.99
- CITIZEN PROJECT INK CARTRIDGE (BLACK) £15.99
- TAILORED PVC PRINTER DUST COVERS £14.99
- For popular Citizen & Star printers - please state printer when ordering.

MONITOR & TV/MONITOR LEADS

- A11 FOR TVs WITH SCART SOCKET (Not for VCRs) £13.99
- incl Sony, Philips, Panasonic, Hitachi, Toshiba, Mitsubishi
- A12 for Ferguson Model/M63/M65with 8 pin Din socket £12.99
- A14 for Hitachi/Granada sets with 7pin Din RGB input £12.99
- A16 for Amstrad CPC464/6128 monitor (with no sound) £12.99
- A16B for new Amstrad CPC stereo monitor £13.99
- A17 for 1084s monitor with 8 pin Din socket £14.99
- A17P for 1083/1084s/8833 with 9pin D socket £14.99
- A111 with 9 pin D plug for multiync monitors £12.99
- A112 with 15 pin row socket for multiync monitors £13.99
- A113 with 15pin 3 row plug for multiync monitors £13.99
- FLICKER FIXER LEAD - 5 plug to 15way 3 row plug £2.99
- MODULATOR EXTENSION LEAD eliminates overhang £10.99
- DELUXE MONITOR STATION fits over Amiga 500 & 500+ includes monitor/computer 1 piece PVC dust cover, mouse mat Has cut out for hard drive. £49.99
- MOUSE & JOYSTICK EXTENSION KIT FOR PLIMM 1 & 2. Ipair £7.99
- MONITOR TILT/SWIVEL BASE for upto 14" monitors or TVs £10.99
- NEWT DUTY SWIVEL BASE FOR UPTO 17" TVs £12.99

THE GREATEST GAMES MAG EVER...

NEW! The greatest show on TV is now a magazine! **£1.75**

BITMAP BROS GAMES MASTER

Sega! Nintendo! Amiga! More!

Issue Two February 1988

140 PAGES!
More reviews!
More previews!
More tips!

MEGA DRIVE
Terminator 2, Micro Machine, Street Talons

SUPER NES
Wild Commander, Sea Wolf, Mickey Mouse

AMIGA
Krazy's Super Fun House, State of Atlanta, Lethal Weapon

20 PAGES OF TIPS:
DYNA BLASTER, JOHN MADDEN 93, BEAST 2, ANOTHER WORLD & MORE!

WIN 10 YEARS WORTH OF GAMES!
Turn to page 124

EXCLUSIVE REVIEW!
THE CHAOS ENGINE
The Bitmap Bros Blast Back!

3D SPECIAL ISSUE!
Available for the 3D TV special offer with FREE GLASSES and GIANT 3D DISC!
*Requires 3D TV and 3D glasses (not included)

Future PUBLISHING
The greatest of new

4
CHANNEL FOUR TELEVISION



...JUST GOT BETTER!



The second issue of GamesMaster magazine goes on sale on January 21. And by God, is it a good one! Nestling between its 140 game-packed pages are more previews, more reviews, more news and more tips across more systems than any other magazine. In short, it's the one-stop-shop for all the video games info you need.

This month there are reviews of the Bitmap Bros' Chaos Engine, Super Star Wars, T2 - The Arcade Game, Micro Machines and many more. You'll find a full 20 pages of tips, including a Dynablaster expert guide, a John Madden 93 strategy special and hundreds of Game Genie and Action Replay codes.

And we're also helping you to prepare for the 3D TV spectacular with a free pair of 3D glasses, a GIANT 3D Chaos Engine Poster and an exclusive look at the brand new 3D game, Starfighter ACE.

ISSUE 2 - ON SALE
THURSDAY JANUARY 21
NOW YOU CAN HOLD THE LEGEND
IN YOUR HAND



the latest AMIGA technology acknowledged experts

STOP PRESS
AMIGA A500+ PACKS
AVAILABLE IN LIMITED
QUANTITIES
Phone us for details

COMPARE OUR TOTAL PRICES
WHAT DO WE MEAN BY THIS?
We'll never try to disguise the total you'll pay by advertising low hardware prices and then when you call, try to add essentials such as cables, delivery and a proper after sales service... all at EXTRA COST! When deciding where to buy, compare our service, check out what the "Extras" really add to those attractive looking prices elsewhere... You'll soon see the REAL COST!

AMIGA 1200
32 BIT-2Mb
68020 PROCESSOR

FIRST NEW AMIGA FOR 5 YEARS AVAILABLE NOW!

The new A1200 is the Amiga of the 90's and the first true advancement to the already powerful Amiga range

Operating at 14MHz this is a revolution in power for the home market. With the new AGA Graphics chip set you have a truly remarkable colour palette of some 16.8 million colours allowing up to 256000 colours at any one time and... it runs the majority of existing software! JUST THINK OF THE IMMENSE POSSIBILITIES!

The A1200 is supplied with 2Mb RAM and has a full one years on site maintenance warranty FREE!

Available at Harwoods with an optional hard disk drive of 80Mb!

Floppy Drive Version ONLY... **£379.95** INC VAT

OR

80Mb Hard Drive Drive Version ONLY... **£679.95** INC VAT

If you want a DIFFERENT SIZE hard drive simply ask for the price!

TRUE 32 BIT POWER FOR EXCELLENT GRAPHICS!



Harwoods new A600 (UK Limited Kingdom specification) include the following features... 1Mb. Disk Drive, 1Mb. RAM, 4096 Colours, Integral TV Modulator, Mouse, Workbench Disks, Manuals, PLUS all Leads - AND... FREE 1 YEAR IN HOME SERVICE!

AMIGA 600
DISK DRIVE VERSION

Available as either...

Pack with Deluxe Paint III and a MYSTERY game

But only whilst stocks last at just... **£269.95**

OR AMIGA 600
DISK DRIVE VERSION

WITH A NEW... **PACK**

WICKED SOFTWARE

PUSHOVER

SILLY PUTTY

PROSE GRAND PRIX

DELUXE PAINT III

at only... **£319.95**

AMIGA 600
HARD DRIVE VERSION

WITH A NEW... **PACK**

EPIC SOFTWARE

EPIC MYTH: ROME

DELUXE PAINT III

TRIVIAL PURSUIT
TRIPLE LANGUAGE VERSION (French, German, English)

MULTI LANGUAGE DICTIONARY

AMIGATEXT WORD PROCESSOR

at only... **£459.95**

If you want a DIFFERENT SIZE hard drive simply ask for the price!

EXCLUSIVE!

POWERPLAY

THE GOLD
SPECIAL EDITION

21 GAMES & WORD-PRO PACK

ADD our great POWERPLAY PACK to your order for only... £49.95

you get: A Superb High Quality Microswitched Competition Pro 5000 Joystick • 1D Essential 3.5" Blank Disks • Disk Storage Box • Tailored A600 Dust Cover and a High Quality Mat to enhance accuracy & protect your mouse

PLUS THE NEW MEGA-RELEASE GAME... ZOO! and a FANTASTIC selection of TWENTY more great games: THESE TITLES ARE NOT PD BUT FULL PROFESSIONAL GAMES WHICH ORIGINALLY SOLD FOR PRICES OF BETWEEN £20 TO £30!!!

Xenon 2 Megablast • Pinball Dreams • TV Sports Football • Hostages • Jumping Jackson • Striker • Bubble Plus • TinTin on the Moon • Bloodwych • Stir Crazy • Krypton Egg • Skychase • Eliminator • Purple Saturn Day • Safari Guns • Lombard RAC Rally • Captain Blood • Strike Force Harrier • Lancaster • Sky Fox II

AND... Transwrite - Word Processor for the Amiga

With ALL THIS you won't need to buy anything more for ages!

why not buy your Amiga A600 with a FULL 2Mb. for just £39.95 extra

0773 836781

*Finance Facilities Available,

from the

0773 836781

If you want the POWER, then
look no further...

Harwoods have put together some great top of the range Amigas that will fit the bill for even the most demanding Amiga user. We've taken the powerful A1500 and tuned it into something extra special with a massive 120Mb. Hard Drive and 3Mb. of RAM, but if that's not powerful enough just look at the spec. of our Amiga A3000 & A4000 packs... and note the price. **WE'VE GOT THE POWER!**

GOLD SERVICE
SEE PAGE 4 FOR FULL DETAILS

AMIGA 1500 3Mb
TWIN FLOPPY DRIVES

THE LATEST workbench
VERSION
2 OPERATING system

But more than an ordinary 1500...

THE SPECIFICATION:

Fitted with a 120Mb. GVP Hard Drive

Twin 3.5" Floppies
3Mb RAM INSTALLED

PLUS SOME GREAT SOFTWARE...

- Toki• •Elf• •Puzznic•
 - Home Accounts•
 - Deluxe Paint III•
 - The Works•
- and the book
GET THE MOST
OUT OF YOUR
AMIGA 1992

£999.95 INC VAT

Phone for prices on other spec. A1500's

15" Monitor/Television

4watts MEGA SOUND
display

Superb definition Philips Monitor TV! Ideal for Amiga/CDTV Users giving for the first time true 80 column text Monitor Quality from a fully featured Teletext television set at a really AFFORDABLE price! Just look at the extensive fetures...

- ★ Direct SCART connector for Amiga, CDTV, VCR or Satellite Receiver.
- ★ RGB/AD, Composite Video & Audio Inputs.
- ★ Full FastText Teletext Facilities (using external aerial socket)
- ★ Headphone Jack Socket ★ 2000 Character High Definition FST Tube, for Superb Text Quality and Graphics Displays
- ★ Supplied complete with Loop Aerial for indoor use
- ★ Infra-Red Remote Control ★ Free lead to your Amiga

GREAT VALUE only...
£239.95

philips monitors
CM8833/II
14" stereo COLOUR with a FREE cable & end dust cover + In-Home Service



philips monitors
GOLD DISCOUNT
CM8833/II
£214.95*
MONITOR/TV
£229.95*

Now with a FREE game: **LOTUS TURBO challenge 2**
Add a CM 8833/II monitor or Monitor/TV when buying your Amiga and pay the low PHILIPS GOLD DISCOUNT prices to save even more! (*only when purchased with an Amiga*)

AMIGA 3000 2Mb

Latest Workbench 2 25MHz. - 2Mb. RAM 52Mb. Hard Drive 3.5" Floppy Drive Including...

FINAL COPY II and AMIGA VISION

ONLY **£1349.95** 52 Mb
ONLY **£1529.95** 105 Mb

free on site maintenance

AMIGA 3000 MONITORS
28" dot pitch **£265.95**
28" dot pitch **£429.95**

AMIGA 4000

Latest 25MHz 68040 CPU, 32 Bit architecture, Built-in Maths Co-Processor, 2Mb Chip RAM, 4Mb Fast RAM, Amiga DOS Version 3, New AGA Graphics chip set, 40 or 120Mb Hard Drives. Including FREE...

FINAL COPY II and 1 Years on site warranty

ONLY **£2099.95** 40 Mb
ONLY **£2129.95** 120 Mb

EXTRA RAM UPGRADES

AMIGAS
A500 1/2Mb £29.95 A500+ 1Mb £39.95
A600 1Mb £44.95
All RAM expansions inc. Battery Backed Real Time Clock

SIMMS FOR GVP'S
HCB & HD8 Drives add RAM in 2Mb. increments
1Mb Simm £27.95 4Mb Simm £99.95
32-Bit SIMM for GVP Accelerators (min. 2Mb. increments)
1Mb x 32Bit £52.95 4Mb x 32Bit £152.95

AMIGA PACK

MULTIMEDIA AT HOME
THE NEW AMIGA CDTV MULTIMEDIA PACKAGE HAS THE LOT
CDTV Player, Keyboard, Infrared Mouse, 3.5" Disk Drive, Workbench Disks, Welcome CD, & Remote

ONLY **£479.95** INC VAT

ENTRY CDTV SYSTEM

CDTV player with Welcome Disk, Remote Controller, Hutchinsons Encyclopaedia & the great game Lemmings

£379.95

CD ROM A570

DRIVE for A500+ use music cd's & CDTV Plus titles on your A500 Plus
Only... **£329.95**

ALL PRICES ARE INCLUSIVE OF

GORDON HARWOOD computers



the **extensive**

range of

peripherals and software

24 GOLD
SEE PAGE 4 FOR FULL DETAILS

EXPAND your system...

and get **MORE** from your AMIGA

If you've got an Amiga why not get **THE MOST** from it....

because it's so easy to attach our add-ons and use some great software, you can quickly get to grips with anything. From Graphic Design, Desk Top Publishing, Video Mixing and Music Composition to many useful business programs such as Word Processors, Accounts, Spreadsheets, Databases etc. You can add advanced technology such as fast Hard Disk Drives for quick access to data, Genlocks & Video Digitisers to import and manipulate images, Sound Samplers to help you with your musical talents and Printers to enable output of your 'your creations'. With a whole lot more available, you too can...

EXPAND YOUR AMIGA EASILY!

AMIGA PRINTERS

DOT MATRIX
INKJETS AND
LASERS

All our printers are supplied for immediate use including a cable, paper and labels **FREE OF CHARGE**.
Dot matrix models come with a tailored dust cover. We also include our specific Amiga driver disks for Citizens, Stars and Canons. ALL Citizens have a 2Year Warranty
Please call for prices on any models not listed

9 PRINTERS
PIN 9 PIN DOT MATRIX

- STAR LC 20 MONO £134.95
- NEW STAR LC 100 COLOUR £164.95
- STAR LC 200 COLOUR £194.95
- CITIZEN 120D+ MONO £124.95
- CITIZEN SWIFT 9 COLOUR £179.95

24 PRINTERS
PIN 24 PIN DOT MATRIX

- STAR LC 24/200 COLOUR £269.95
- XB 24/200 COLOUR £369.95
- CITIZEN SWIFT 200 MONO £209.95
- SWIFT 200 COLOUR £239.95
- SWIFT 240 MONO £249.95
- SWIFT 240 COLOUR £269.95

HIGH RES PRINTERS
HIGH RESOLUTION

- STAR SJ48 INKJET £209.95
- CANON BJ10ex INKJET £224.95
- CANON BJ20ex INKJET including automatic sheet feeder £319.95
- HP DESKJET 500 MONO £369.95
- HP DESKJET 550 COLOUR...NEW £649.95
- HP PAINTJET COLOUR £679.95
- STAR LASERS FROM... £749.95

GENUINE PRINTER ACCESSORIES CONSUMABLES AND UPGRADES

PRINTER	PRINTER TYPE	BLACK RIBBON	BLACK RIBBON 'SIX PACK'	COLOUR RIBBON	COLOUR RIBBON 'SIX PACK'
CITIZEN 120D+	BLACK ONLY	£4.75	£22.95	N/A	N/A
CITIZEN 124	BLACK ONLY	£4.75	£22.95	N/A	N/A
CITIZEN SWIFT 9	BLACK/COLOUR	£4.75	£22.95	£16.45	£94.95
SWIFT 24/24E/224	BLACK/COLOUR	£4.75	£22.95	£16.45	£94.95
STAR LC10/20/100	BLACK/COLOUR	£4.45	£23.95	£5.95	£34.95
STAR LC200	BLACK/COLOUR	£5.95 ZX9	£32.95 ZX9	£12.45 ZX9CL	£64.95 ZX9CL
STAR LC24/200	BLACK/COLOUR	£6.95 Z24	£39.95 Z24	£12.95 ZX2CL	£69.95 ZX2CL
STAR XB RANGE	BLACK/COLOUR	£8.95 Z24	£49.95 Z24	£14.95 ZX2CL	£74.95 ZX2CL
STAR SJ48 INK CARTRIDGE	BLACK ONLY	Also compatible with Apple Stylewriter and Canon BJ10ex Bubblejet			£15.95ea.

- Hewlett Packard Original Consumables**
- DESKJET 500...**
 - Black Ink Cartridge £21.95
 - [Double Life]
 - Colour Ink Cartridge [Std] £25.95
 - PAINTJET...**
 - Black Ink Cartridge £22.95
 - Colour Ink Cartridge £24.95
 - Single Sheet Paper £20.95
 - Z-Fold Paper £18.95
 - Transparency Film: £52.95
 - [Pack of 50 Sheets]

- Citizen Accessories:**
- 80 Column 9/24 Pin £37.95
 - Printer Colour Kit [ALL models except the Citizen 124 model] £13.95
 - 32K RAM Expansion [24Pin Citizens except 200/240] £19.95
 - 32K RAM Expansion [Citizen 200/240] £19.95
 - 128K RAM Expansion [Citizen 200/240] £32.95

AUTOMATIC SHEET FEEDERS:
ALL Star & Citizen 80Column models
Only...£69.95

Please phone for items not listed

[please state model when ordering]

AMIGA HARD DRIVES

- 20Mb. Only... £199.95
 - 60Mb. Only... £299.95
 - 80Mb. Only... £349.95
- Prices include courier collection & return of your Amiga, installation & a full 12month Gold Warranty for both your drive and Amiga.

600HD Owners, trade up your 20Mb. Hard Drive! Phone for details.

HARD DISK DRIVES with 2yrs warranty

A500 and PLUS Simply plug in to the Amiga sideport

HD8 Hard Drives

RAM	80Mb.	120Mb.
0Mb.	£369.95	£429.95
2Mb.	£419.95	£479.95
4Mb.	£469.95	£529.95
8Mb.	£569.95	£629.95

A530 Combined Hard Drive and 68030 Accelerator

RAM	80Mb.	120Mb.
1Mb.	£649.95	£719.95
2Mb.	£699.95	£779.95
4Mb.	£799.95	£879.95
8Mb.	£949.95	£1009.95

68882 Maths floating point unit for A530's £219.95

AMIGA internal 1500 2000 HARD DISK DRIVE

HC8 Hard Drives

RAM	80Mb.	120Mb.
0Mb.	£329.95	£399.95
2Mb.	£379.95	£449.95
4Mb.	£429.95	£499.95
8Mb.	£529.95	£599.95

NB!!! Hard drives fitted with memory may fluctuate in price due to the \$/£ exchange rates. Please confirm prices when ordering.

CUMANA 3.5" drive EXTERNAL floppy
with free disk head cleaner
-LONG CONNECTING-CABLE - THROUGHPORT -
£54.95

0773 836781

*Finance Facilities Available,

AMIGA

0773 • 836781

AMIGA software

Listed below is a sample from our vast range of software at competitive prices. If you need a product not listed simply phone us and we will be delighted to quote for your requirements.

word processors/publishing

Pen Pal V1.4	£49.95
Final Copy II V2.0	£99.95
Kindwords 3	£39.95
Wordworth V1.1	£109.95
Transwrite	£29.95
Prowrite 3.3	£79.95
Pagestream V2.2	£129.95
Professional PageV3.0	£129.95
Pagesetter II	£44.95
SoftClips Clip Art...	
Classic Clip Art	£29.95
People Clip Art	£29.95
Collectors Clip Art	£29.95
Animal Clip Art	£29.95
Electric Thesaurus	£29.95

animation and graphics

Deluxe Paint 4	£64.95
Real 3D Professional Turbo	£249.95
Art Department Professional V2	£144.95
DCTV Composite Video 24-Bit Graphics System (PAL)	£379.95
Imagine 2.0	£189.95

integrated titles

Mini Office	£39.95
Gold Disk Office	£59.95

databases

Homebase	£19.95
Superbase 2 Personal	£29.95
Gallery Pictorial Slide Show/DB	£39.95

CAD & structured drawing

Intro CAD Plus	£79.95
X-CAD 3000	£269.95
Professional Draw 3	£89.95

video

Scala 500	£79.95
Scala Professional	£199.95
Broadcast Titler 2	£179.95
Pro Video Post	£169.95
Video Studio V3	£119.95

utilities & development

Disk Master V2	£44.95
Quarterback V5	£44.95
Quarterback Tools	£54.95
Dos-2-Dos	£29.95
Easy Amos	£24.95
Amos The Creator	£36.95
Amos Compiler	£23.95
Amos 3D	£25.95
Amos Professional	£49.95
New SAS Lattice C V6	£219.95
Devpac 3	£54.95
Directory Opus	£27.95

miscellaneous

GB Route Plus	£39.95
Professional Calc	£124.95

games & entertainment

Phone for access to our massive competitively priced range now!

AMIGA + - x ÷ a b c software

FOR EDUCATION

micro maths - to GCSE standards	£18.95	AD1 titles 11to12: english £18.95
micro english - to GCSE standards	£18.95	maths £18.95
micro french - to GCSE standards	£18.95	french £18.95
micro german - to GCSE standards	£18.95	AD1 titles 12to13: english £18.95
primary maths - 3to12's	£18.95	maths £18.95
mega maths - A level	£19.95	french £18.95
reading and writing		first shapes - 3to8 £12.95
course - over 3's	£18.95	puzzle story book - 3to8 £19.95
compendium six	£29.95	dinosaur discovery kit - 3to8 £19.95
fun school 4 software:		first letters and words - 3to8 £12.95
choose - under 5's, 5to7's		NEW...Childs Play Activity Centre & Word Processor with SPEECH, 2to12yrs or 7to11's, only...£19.95 each

AMIGA BOOKS

Amiga for Beginners	£12.95
Getting the most from your Amiga	£13.95
Amiga Machine Language	£14.95
Amiga DOS inside and out	£21.95
Amiga Hardware reference manual	£21.95
Amiga C for beginners	£13.95
Other Books: ...call us with your requirements	

AMIGA accessories

Digiview Media Station	£134.95
Colour Pic Plus	£679.95
Super Pic	£579.95
Rombo Vidi 12	£89.95
Amas 2 Sound Sampler & Midi Interface inc. Microphone	£79.95
Audio Engineer Plus	
Sound Sampler	£179.95
Technosound Turbo	
Sound Sampler	£29.95
Miracle keyboard music teaching system for the Amiga	£299.95
Music X (full version 1.1 whilst stocks last)	£19.95
Midi interface 5 port with two cables	£24.95
Super JAM	£84.95
Bars & Pipes Professional	£219.95
ZYFI Stereo Speakers with a separate power supply	£39.95
Power Mono Hand Held Scanner	£98.95
Power Colour Hand Held Scanner	£239.95
Sharp JX 100 Colour Flatbed [A6 Paper size]	£549.95
ProGen - Perfect high quality entry level true video signal genlock	£64.95
Rocgen Plus	£119.95
Multi connection cable kit for all genlocks	£14.95
HQ Microswitched mouse	£13.95
HQ Microswitched mouse inc. Mouse Mat & Holder	£19.95
Naksha Microswitched mouse with Mat & Holder	£21.95
High Quality microswitched Optical mouse	£28.95
HQ Microswitched Trackball	£29.95
Superb Automatic Mouse and Joystick Switcher	£17.95

AMIGA MICE genlocking devices

KCS Powerboard Plus 512K RAM (Please state A500 or plus when ordering - not A600 compatible)	£184.95
Now supports most hard drives! supplied without DOS	£124.95
supplied with DOS 4.01	£124.95
1500/2000/3000 adaptor	£69.95
GVP 286 PC emulator card for A500 HD8/530 (no DOS). Simply plugs into your GVP drive	£189.95

AMIGA PC Emulators

Premier Control Centre & Monitor Plinth with shelf:	
For Amiga A500	£39.95
For Amiga A600	£34.95
Zipstick autofire	£11.95
Competition Pro-Star autofire, burstfire & slow motion	£13.95

Full range of Quickjoy and other makes stocked - call for prices

10 Sony 3.5" DS DD	£8.95
50 Sony 3.5" DS DD	£34.95
Certified Bulk Disks with labels: 10 with library case	£6.95
50 Disks - only...	£24.95
250 Disks - only...	£79.95
3.5" Disk Head Cleaner essential for reliable loading	£2.95

GOLD SERVICE

Before you choose from whom to purchase, please phone us. We are always happy to discuss your requirements and answer any queries you may have. And... remember Harwoods have always provided THE BEST service in the industry...

FREE GOLD SERVICE: Any computer, monitor or printer that requires service in the first year is collected FREE OF CHARGE (UK Mainland only). Remember at Harwoods we charge no more for this GOLD service. The fastest turnaround possible is GUARANTEED by our OWN SERVICE ENGINEERS. Many items have In-Home Warranties - TECHNICAL SUPPORT: You will be given our Exclusive Technical Support Phone Number to call should you require any help or advice on any aspect of the system you have purchased.

MINIMUM 12 MONTH HARDWARE WARRANTY: Items proving faulty within 30 days of purchase are replaced with NEW UNITS unless otherwise stated. For the guarantee period, warranty service will be completely FREE OF CHARGE (some items are 2 yr warranty). **YOUR SYSTEM READY TO GO:** All main hardware products come with mains plugs and leads - just connect up and use straight away.

How to contact us...

BY PHONE: Phone our Order Hotline with your Access, Visa, Mastercard Switch or Lombard Creditcharge Card quoting number & expiry date (Most Dixons, Currys, NASCR and other "store" cards are Lombard Creditcharge and are happily accepted by us).

BY POST: Make cheques, bankers building society drafts or postal orders payable to GORDON HARWOOD COMPUTERS. (Personal/business cheques take 7days to clear from day of receipt whereupon your order will be despatched). Please send Name, Address, and most importantly if possible, a Daytime Telephone Number along with your order requirements. Please check you are ordering from our latest advertisement before posting (phone if you require confirmation). Please remember that for example many September publications appear during August, etc., therefore prices you see may have changed (either up or down!).

EXPORT: Most items are available at TAX FREE PRICES to non UK residents and service personnel. Please contact us for confirmation of export prices before ordering.

FREE DELIVERY: by Parcel Force, UK Mainland only. OR: **SPEEDY NEXT WORKING DAY COURIER SERVICE.** Add just £6.95 per major item for guaranteed delivery (or £7.50 for Saturday delivery). UK Mainland most regions. (Despatch normally on day of order or payment clearance).

All listed prices are what YOU PAY, and there are NO HIDDEN EXTRAS. VAT and postage are included, and prices are correct at time of going to press (Pack details may vary from time to time). Offers and Services are subject to availability and to being the latest advertised products, packs and prices. Please note goods are not supplied on a trial basis. E&OE.

VISIT OUR SPACIOUS SHOWROOM:

Why not take a trip out to visit us and see our full advertised range, and more, available at the SAME COMPETITIVE PRICES. (Please see opening times) There's plenty of FREE parking nearby too!

How to find us...

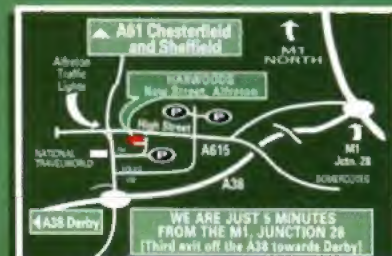

OPENING TIMES
9.00 until 5.00 Monday to Saturday
Wednesdays - 9.00 until 1.00

GORDON HARWOOD Computers

Enquiries & Order Line:
0773 836781

Finance Facilities Available*

*Please phone us for information, your personal application pack and full written details.



GORDON HARWOOD COMPUTERS
DEPARTMENT AMF /H3, NEW STREET,
ALFRETON, DERBYSHIRE. DE5 7BP
TEL: 0773 836781 FAX: 0773 831040

The Closer you look, The Better we look.

ALL PRICES ARE INCLUSIVE OF

VAT AT 17.5%

AMIGA POWER ...The Video

AMIGA POWER TIPS

Played and presented by
Matthew Squires

IN ASSOCIATION WITH
AMIGA
FORMAT MAGAZINE

The video that's packed with
hints, tips, and playing guides
for all Amiga games players!

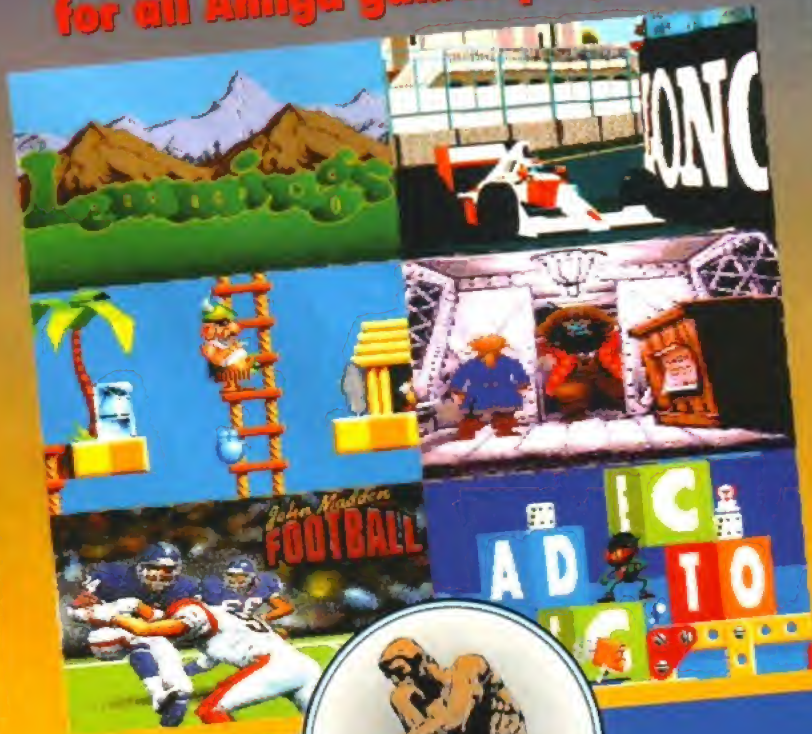

WONDERLAND

A Power packed hour of sensational tips from Britain's biggest selling Amiga games magazine.

At only £9.99, the AMIGA POWER Tips Video is available from Woolworths, WH Smith, and all good video and computer stockists.

RICOH PCL5 LASER PRINTER

Ricoh UK Ltd is part of the worldwide Ricoh Group of companies, originally established in Japan, in 1936. With a turnover of over \$5 billion and 37,000 employees, Ricoh have been producing computers and peripherals since 1971 and are the world's second largest manufacturer of Laser Printer engines. Ricoh have employed their expertise to produce a 'first' in laser printers for the world market, the LP1200 with FLASH ROM.

Fully HP LaserJet III™ compatible, the LP1200 employs industry proven laser technology. Unlike LED page printers, which use light emitting diodes, the LP1200's laser lightsource, focussed by high quality lenses, is able to produce the most accurate and intense printed images. Its fast, efficient processor and engine, together with a straight paper path design, allows printing at a full 6 pages per minute. Unlike its competitors, the LP1200 can print an A4 page of graphics at 300dpi with its standard memory. Also, Ricoh's advanced laser engine enables the LP1200 to address a range of print resolutions up to 400dpi. The standard 2Mb of RAM installed allows the LP1200 to print a full A4 page of text using standard internal resident fonts, or an A5 page of graphics, both at 400dpi. A FREE Windows driver supplied enables the Ricoh LP1200 to print a typical page of text at 400dpi from Windows 3 using the controller firmware currently installed on the printer and standard internal resident fonts. A 2Mb RAM upgrade (total 4Mb RAM) is required to print an A4 page of graphics.

Again, unlike the competition, the LP1200 includes a powerful document description language as standard. This language, 'LAYOUT', offers unique opportunities to develop custom-made printing systems. Forms and document templates can be designed and stored electronically in the LP1200's FLASH ROM, alleviating the need for pre-printed forms!

SHOWN WITH UNIVERSAL FEEDER TOP TRAY (OPTIONAL EXTRA)



The Ricoh LP1200 is a genuine laser printer and not an LED printer. Make sure you check out the competition!

See how the Ricoh LP1200 compares to its Laser Printer Competitors

CORPORATE SALES TEAM
Tel: 081-308 0888 Fax: 081-308 0608

FEATURES	EPSON EPL4100	HP LJ/JET IIP	M'MAN TALLY MT904+	IBM 4029 Model 010	RICOH LP1200
Average Street Price (excl. VAT) (*expected)	£569	£699	£699*	£750	£699
Official RRP (excl. VAT)	£945	£1,179	£1,099	£1,099	£1,195
Maximum resolution in dots per inch	300 x 300	300 x 300	300 x 300	300 x 300	400 x 400
Windows 3 Driver @ 400 dpi	-	-	-	-	YES
Print Speed	6ppm	4ppm	4ppm	5ppm	6ppm
Straight Paper Path	YES	-	-	-	YES
PCL 5 Printer Command Language	-	YES	YES	-	YES
HP-GL/2 Vector Graphics included	-	YES	YES	YES	YES
Resolution Improvement/Enhancement	YES	YES	YES	YES	YES
Standard RAM	0.5Mb	1Mb	1Mb	1Mb	2Mb
Full A4/300 dpi graphics with standard RAM	-	-	-	-	YES
Warm Up Time	<45 secs	<60 secs	60 secs	33 secs	45 secs
First Page of Text Output	<20 secs	<40 secs	34 secs	20 secs	<15 secs
Document Description Language included	-	-	-	-	YES
Flash ROM	-	-	-	-	YES
Upgradable Firmware	-	-	-	-	YES
IC Card Slot	YES	-	-	YES	YES
Scalable Resident Fonts - in HP LJ III Emulation	-	8	8	0	8
Resident Bit-Mapped Fonts	11	14	14	16	14
AGFA Intelligent Scalable Font Technology	-	YES	-	-	YES
HP LaserJet III Emulation Included	-	YES	YES	-	YES
EPSON FX Emulation Included	YES	-	YES	-	YES
IBM ProPrinter Emulation Included	-	-	YES	-	YES
Standard Tray Capacity	100	70	100	200	100
Protective cover on standard tray	YES	-	YES	YES	YES
Cost per copy**	1.65p	2.00p	1.71p	1.64p	1.65p
Min-Max Paper Weight in gsm	60-157	60-105	60-120	60-131	60-157
Able to print on OHP Film	YES	YES	YES	YES	YES
Able to print on card (157gsm - Manual Feed)	YES	-	-	-	YES
Standby -Noise Level	<40dB	31.7dB	<35dB	38 dB	<38dB
Printing -Noise Level	<50dB	43.3dB	<46dB	50 dB	<48dB

*As quoted by manufacturers - 2/4/92

© Trademarks are acknowledged

HP LASERJET III™ COMPATIBLE

400 dpi 2 Mb RAM 6 PPM

A4 TEXT/AS GRAPHICS @ 400dpi • A4 GRAPHICS @ 300dpi
A 2Mb RAM UPGRADE IS REQUIRED TO PRINT AN A4 PAGE OF GRAPHICS AT 400dpi

FLASH ROM UPGRADEABLE!



RICOH LP1200

• 6 PAGES PER MINUTE
Using a straight paper path

• PCL5 - inc HP-GL/2

With scalable fonts and vector graphics

• SHARP EDGED PRINTING

Ricoh FIAL (Fine Image ALgorithm) enhances resolution

• 400dpi RESOLUTION

(Default res. - 300dpi. Will address 200, 240 & 400dpi.)

• 2Mb RAM AS STANDARD

• UNIQUE FLASH ROM

For controller upgrade and storage

• IC CARD SLOT

For programmable FLASH ROM cards

• EXPANSION BOARD SLOT

For improved connectivity eg. Coax/Twinax, PC-LAN etc

• LAYOUT Document Description Language

• SERIAL + PARALLEL PORTS

• 1 YEAR ON-SITE WARRANTY Next working day response

Silica Systems are pleased to introduce the revolutionary Ricoh LP1200. It has all of the specifications that you would expect to see in today's most technically advanced laser printers, plus a unique additional feature which places it far ahead of the competition - FLASH ROM. This 'Future Proof' technology protects the investment you make when you buy a Ricoh LP1200, as it enables you to keep up to date with new laser firmware developments. FLASH ROM is an area of memory inside the LP1200 which holds the printer's controller instruction firmware. If new firmware is developed, eg an update to the printer's command language, it can be downloaded into this memory. Other manufacturers would require you to buy a new printer! Fonts, macros, graphics and additional emulations can also be stored in FLASH ROM, or on removable, industry standard FLASH ROM IC cards. The new Ricoh LP1200 is the only laser printer to offer this FLASH ROM facility. The LP1200 comes with a 100 sheet A4 paper tray (letter and legal trays also available as extras) and the facility to feed single sheets of paper and card up to 157gsm. An optional extra universal feeder provides the facility to automatically feed up to 150 sheets, from sizes of 98mm x 148mm to 216mm x 356mm in size at weights of up to 158gsm. The universal feeder also feeds up to 15 envelopes, overhead transparencies and labels automatically.

Consumables + Accessories

CODE	PRODUCT	PRICE Excl VAT
CAB 7500	Cable for PC/ST/Amiga	£8.47
KIT 5200	Laser Starter Kit inc Cable	£12.50
LAA 5238	Universal Feeder (2nd Tray)	£100.00
LAA 5262	2Mb RAM Module	£149.00
LAA 5210	Developer/Toner Cartridge	£55.00
LAA 5225	OPC Cartridge (Drum)	£89.00
LAA 5334	Letter Paper Tray (100 Sheets)	£35.00
LAA 5323	Legal Paper Tray (100 Sheets)	£35.00
LAA 5312	A4 Paper Tray (100 Sheets)	£35.00

CALL FOR A FULL PRICE LIST

*Note: A4 paper tray is already included in the £699 price. More A4 trays can be purchased to feed different coloured stationery.

LP1200 WITH SINGLE BIN & 2Mb RAM SILICA PRICE:

£699

+VAT= £821.33 Ref: LAS 5200

PCMCIA FLASHCARDS ARE AVAILABLE FROM SILICA. THESE ALLOW ADDITIONAL SOFTWARE FONTS TO BE DOWNLOADED VIA A PC.

121190-1030

SILICA SYSTEMS OFFER YOU

- **FREE OVERNIGHT DELIVERY:** On all hardware orders shipped in the UK mainland.
- **TECHNICAL SUPPORT HELPLINE:** Team of technical experts at your service.
- **PRICE MATCH:** We normally match competitors on a "Same product - Same price" basis.
- **ESTABLISHED 14 YEARS:** Proven track record in professional computer sales.
- **£12 MILLION TURNOVER (with 60 staff):** Solid, reliable and profitable.
- **BUSINESS + EDUCATION + GOVERNMENT:** Volume discounts available 081-308 0688.
- **SHOWROOMS:** Demonstration and training facilities at our London & Sidcup branches.
- **THE FULL STOCK RANGE:** All of your requirements from one supplier.
- **FREE CATALOGUES:** Will be mailed to you with offers + software and peripheral details.
- **PAYMENT:** Major credit cards, cash, cheque or monthly terms.

Before you decide when to buy your new laser printer, we suggest you think very carefully about WHERE you buy it. Consider what it will be like a few months after you have made your purchase, when you may require additional peripherals or consumables, or help and advice with your new purchase. And, will the company you buy from contact you with details of new products? At Silica Systems, we ensure that you will have nothing to worry about. We have been established for almost 14 years and, with our unrivalled experience and expertise, we can now claim to meet our customers' requirements with an understanding which is second to none. But don't just take our word for it. Complete and return the coupon now for our latest FREE literature and begin to experience the "Silica Systems Service".

MAIL ORDER HOTLINE
081-309 1111

SILICA SYSTEMS

MAIL ORDER: Order Lines Open: Mon-Sat 9:00am-8:00pm No Late Night Opening	1-4 The Mews, Hatherley Rd, Sidcup, Kent, DA14 4DX	Tel: 081-309 1111 Fax No: 081-308 0608
LONDON SHOP: Opening Hours: Mon-Sat 9:30am-6:00pm No Late Night Opening	52 Tottenham Court Road, London, W1P 0BA	Tel: 071-580 4000 Fax No: 071-523 4737
LONDON SHOP: Opening Hours: Mon-Fri 9:30am-7:00pm (Sat close 6:30pm) Late Night: Thursday - 8pm	Selfridges (1st Floor), Oxford Street, London, W1A 1AB	Tel: 071-629 1234 Extension: 3914
SIDCUP SHOP: Opening Hours: Mon-Sat 9:00am-5:30pm Late Night: Friday - 7pm	1-4 The Mews, Hatherley Rd, Sidcup, Kent, DA14 4DX	Tel: 081-302 8811 Fax No: 081-309 0017
ESSEX SHOP: Opening Hours: Mon-Fri 9:30am-5:30pm (Sat 9:00am-6:00pm) No Late Night Opening	Keddies (2nd floor), High Street, Southend-on-Sea, Essex, SS1 1LA	Tel: 0702 462426 Fax No: 0702 462363

To: Silica Systems, AMFOR-0293-75, 1-4 The Mews, Hatherley Rd, Sidcup, Kent, DA14 4DX

PLEASE SEND INFORMATION ON THE RICOH LP1200

Mr/Mrs/Miss/Ms: Initials: Surname:

Company Name (if applicable):

Address:

Postcode:

Tel (Home): Tel (Work):

Which computer(s), if any, do you own?

75L



THE CENTRE OF TEC

WTS ELECTRONICS LTD, CHAUL END LANE, LUTO



- Amiga 600 Pack**
- UK specification
 - 1MB system RAM
 - Mouse
 - Full workbench disks, manuals & leads
 - Free game included in pack
 - Deluxe Paint III or Photon Paint III
 - Two Python joysticks
 - 100 capacity lockable disk box **£295**
- Amiga 600 HD Pack**
- Plus internal 20MB hard drive **£395**
 - Plus internal 40MB hard drive **£475**



- Amiga 1500/2000 Pack**
- 1MB System RAM
 - Workbench 2.04
 - Twin Floppy
 - Mouse
 - Works (Platinum addition)
 - Deluxe Paint III
 - Home Accounts
 - Elf game • Toki game • Puzznic game
 - Two Python joysticks
 - 100 capacity lockable disk box
- Amiga 1500/2000 Pack **£489**
 - A1500/2000 with 52MB HD **£759**
 - With 2MB Chip Memory add **£129**



- Wierd, Wild & Wicked A600**
- Game players paradise
 - Push Over game
 - Formula 1 Grand Prix game
 - Putty Game
 - Extra free game
 - Deluxe Paint III
 - 2 Python joysticks
 - 100 Capacity disk box
- A600 Pack **£329**
 - A600 Pack & 20MB hard drive **£429**
 - A600 Pack & 40MB hard drive **£509**



- A1200 Pack**
- 32-bit 68020 Full power
 - Super Hi-Res graphics
 - 2MB Chip memory
 - PCMCIA Technology
 - Alpha numerical keypad
 - Two Python joysticks
 - Free game
 - 100 Capacity disk box
- A1200 Pack **£385**
 - A1200 with 20MB hard drive **£485**
 - A1200 with 40MB hard drive **£585**



- Philips 8833 MKII Monitor**
- 14 inch high resolution colour display
 - High clarity stereo sound output
 - Full RGB and composite inputs
 - Free 1.5 metre long RGB cable
 - Full UK warranty
 - 3 Free games
- Philips 8833 MKII Monitor **£199**
 - When purchased with an Amiga **£189**



- Star Printers**
- **Star LC20 Mono**
 - 180 characters per second, NLQ mode, multi font, 9 pin head **£139**
 - **Star LC200 Colour**
 - 225 characters per second, NLQ mode, multi font, 9 pin head **£199**
 - **Star LC24-100 Mono**
 - 204 characters per second, LQ mode, 10 fonts, 24 pin head **£194**
 - **Star LC24-200 Colour**
 - 222 characters per second, LQ mode, 10 fonts, 24 pin head **£284**
 - **Star SJ48 Bubble Jet**
 - Quality comparable with a laser printer, very quiet and portable. Mains and battery powered, adaptor supplied **£224**



- Workstations**
- Ergonomically sound
 - Facilitates up to three external floppy drives
 - Made in the UK
 - Strong and robust
 - Aesthetically pleasing
 - Keep your desk neat and tidy
 - Supplied complete and assembled with free mouse mat
- A500 Workstation **£36**
 - A600 Workstation **£36**
 - Swivel and tilt monitor stand for the above **£5**



- Peripherals**
- 100 Capacity lockable disk box **£4.99**
 - Squick mouse **£13.99**
 - Mouse mat **£1.99**
 - TDK high quality DSD (10) disks **£9.99**
 - 1000 colour disk labels **£12**
 - LC20 printer ribbon **£3.49**
 - Jet Fighter joystick **£13.99**
 - Apache joystick **£6.99**
 - Python joystick **£9.99**
 - Zipstick joystick **£14.99**
- Vast range of leads for many applications - **Please call**



- Scanners**
- Allows image processing in a useful and unique fashion
 - Comes complete with operation manual and the latest version of processing software
 - One of the fastest growing applications for home and professional users
 - High specification coupled with cost effective pricing
- **Power Hand Scanner**
 - 64 greyscales 100-400 DPI
 - Thru'port to printer
 - Fully compatible with Delux Paint 4, etc.
 - Power Hand Scanner **£93.99**



- Music**
- Highest quality stereo sound sampling
 - Compatible with A500, A1500/2000, A3000
- GVP Digital Sound Studio **£49**
 - Screen Beat Speaker System **£25** (Adds amplified stereo sound to the Amiga)
 - Megamix Master **£37**
 - Stereo Master **£34**

TECHNICAL EXCELLENCE

Est. since 1984



WTS, BEDS, LU4 8EZ TEL (0582) 491949 (6 LINES)



Pro Agnus 2MB

- Provides a full 2MB of Chip Memory for the Amiga 500 and A1500/2000
- Designed and built in England
- Supplied with 8375 Obese Agnus
- Includes 2Mb Memory on board in the form of low power Zips
- Allows the processing of elaborate animation and sound sampling
- Provides the same max. chipmem as the A3000/A600 & 500+
- Increases addressable memory space from 9MB to 10MB
- Complete with full instructions
- British made

• Pro Agnus 2MB **£139**
• Fitted **£159**



Memory Expansions

A500 Pro-RAM 0.5 Meg. Upgrade

- Chip memory compatible
- British made
- Without clock **£16**
- With clock **£19**

A500 Pro-RAM 1.5MB Memory Upgrade

- Gives a full 2MB of internal memory **£74**

A500+ 1MB Memory upgrade **£29.95**

Supra RX500 (2MB-8MB)

- 2MB **£138**
- 4MB **£194**
- 8MB **£299**

A600 1MB Memory upgrade **£38**
10MB Memory upgrade A500 **£408**

High Current Power Supply



- Allows the addition of peripherals without damage to computer or power supply
- Why risk damaging your expensive kit when one simple investment will ensure total peace of mind now and for the future
- Switch mode design
- Full crow bar projection
- A500, A500+ and A600 compatible
- British Made

• A500 Power supply unit **£44.95**
• A590 Power supply unit **£44.95**

Cumana 3.5" External Drive



- High Quality
- Renowned and proven reliability
- Top notch specification
- Anti-click
- Long moulded cable
- Slimline design
- High impact plastic

• Cumana external drive **£54**
• Cumana external drive + 100 capacity disk box **£57**
• Cumana external drive + 100 disk box + 20 blank disks **£63**
• A500/A500+ Internal replacement disk drive **£39**

Supra Modems



- Utilise hundreds of PD Bulletin Boards
- Communicate with fellow computer users
- Cuts down on telephone bills by using fast efficient baud rates
- 100% Hayes compatible
- Tone pulse, Auto Dial/Auto Answer
- Standard RS232 Interface
- Programmable number storage
- Free Coms software

• Supra 2400 **£84**
• Supra 2400+ **£129**
• Supra Fax Plus (0-9600 BPS) **£148**
• Supra v.3.2 (Fax Modem) **£199**
• Supra v.32 BIS (Fax Modem) **£258**

Chips and Spares



- WTS have sole distribution rights from Americas biggest Commodore chip distributor

• Workbench 2.04 Kit (includes manuals, disks & chip) **£78**
• Kickstart 2.04 **£32**
• Kickstart 1.3 **£24**
• Kickstart ROM Swapper (Swap between kickstarts) **£18**
• Fatter Agnus 8372 **£32**
• Obese Agnus 8375 **£48**
• High Res Denise **£29**
• 1MB x 9 Simms **£22**
• 1MB x 4 Zips **£16**
• 8520 CIA **£8**

SALES HOTLINE 0582 491949 (6 LINES) OR 0480 471117

Credit Card ordering by phone is easy. Simply phone our sales hotline quoting your credit card number., expiry date, name and address and the products you wish to order and we'll do the rest. Alternatively write the above details on your letter when ordering by post.

When ordering by post in cheque form please write your cheque card guarantee number on the reverse of the cheque and send along with your order. Postal Orders are also accepted.

NO DELIVERY CHARGES TO UK MAINLAND. NO MINIMUM ORDER AMOUNT.
Should you wish your order to be sent by Group 4 Security service please add £5. This method is normally faster than the postal service.

WARRANTY: One year return to base (excluding chips).
ONE YEAR EXTENDED WARRANTY: Available on all products (excluding chips) at 10% of purchase price when ordering.

WHERE TO FIND US!

Head Office
WTS Electronic Ltd
Chaul End Lane
Luton
0582 491949

Computer Mall Bedford
No.16 Downstairs
The Harpur Centre
Bedford
0234 218228

Computer Mall St. Neots
No.6
Priory Mall Shopping Centre
St. Neots
0480 471117

Computer Mall Hertford
49 Railway St.
Hertford
0992 503606

Computer Mall Dunstable
84 High Street North
Dunstable
Bedfordshire
0582 475747

All prices quoted or products stocked are subject to stocking levels and availability. WTS cannot be held liable for force majeure, or items, which are out of stock due to demand or low stock at its suppliers. WTS reserve the right to amend prices or revise packs or specifications without prior notice at any time without liability upon itself.



War in Europe is what everybody fears most, and making a game of it could be considered tasteless. But Blue Byte add a bit of history to make their Great War a real thought-provoker.

The last people on earth you'd expect to be doing a game about the First World War are, let's face it, Germans. But those brave guys at Blue Byte, the small but perfectly-formed software house from Dusseldorf, have done just that. They've taken the bare bones of their earlier, much-acclaimed game *Battle Isle*, added a vast amount of historical background and detailed WWI tactics, and produced what is probably the best strategy wargame we've ever seen.

HistoryLine 1914-1918 begins with an impressive 'from-the-trenches' animation of a night battle, and then moves on to a longer, even more detailed animation of the murder of Archduke Franz Ferdinand, the heir to the Austro-Hungarian throne. This was the flame which set alight the tinder-dry tempers of Europe. A detailed account of the many treaties, war preparations and pacts which led up to this moment follows in another animated sequence. The end result, as our grandfathers knew to their cost, was four years of the bloodiest war this world has ever seen.

Once you've made it past the enthralling intro sequences and the hairs on the back of your neck have relaxed again, you find yourself at the main menu. This is where *HistoryLine* can be altered according to taste. You can opt for one-player battles against the computer (you choose whether to control the Germans or the French), or two-player head-to-head battles.

You can set the game so that individual battles are resolved using animations, or just a quick calculation and a result. This is ideal if you're running the game from floppy and the disk-access is too much - but it's worth checking over the battles at least once or twice. Better still, install *HistoryLine* to hard drive.

HistoryLine is very intuitive and very, very playable. *Battle Isle* owners will already be familiar with the way *HistoryLine* works, and newcomers will find it just as satisfying. *HistoryLine* uses a view very similar to the one featured in *Battle Isle*, and many of the controls are the same. The main difference is



The event that threw Europe into four years of miserable war: the assassination of ArchDuke Franz Ferdinand in Serbia, 1914. Blue Byte's *HistoryLine* is an animated lecture as well as a stunning game.

HistoryLine 1914-1918

in the graphics and tactics, both of which are much-improved and even more detailed. The game takes place in two phases: movement and fire. While player one is moving, player two (or the computer) is firing or using units, and when each player has finished, any battles and conflicts are resolved using the battle animations. When that's done, the players swap actions, and the whole thing repeats.

All actions can be controlled using either joystick, mouse or keys, depending on the way you set up the main menu, though joystick control is probably the easiest. To move units or examine them, you move the cursor over their position, hold down fire, and move the joystick in one of four directions. This changes the cursor into a different icon, depending on the direction and the current turn phase.



As you go into battle, you can double-check the strength and power of the units you're bringing to bear on the enemy.



HistoryLine takes you through the whole bloody war - and winter campaigns are a lot harder than those in the summer.

DON'T MENTION THE WAR

Blue Byte's head man, ex-programmer Thomas Hertzler, was the visionary behind the *HistoryLine 1914-18* project. He's quick to point out that the point of the game is not to glorify war, but to present the important facts about why they start.

According to Thomas, Germans especially don't like talking about the giant conflicts they've managed to get themselves into - and you'd be considered a bit militaristic if you were overheard discussing the Somme in the local Bierkeller. The constant suppression of the past and the denial of the facts was something Thomas felt was unhealthy, and potentially dangerous.

"If everyone tries so hard to deny that what happened, happened, we'll be too slow to realise if it looks like happening again. The healthy way is to talk about it, accept it and perhaps understand it a bit more. Maybe then we'll all be a lot safer." Sound sentiments, and ones which have resulted in one of the most well-polished, beautifully presented and playable games this year.



Details, details: lovely touches like the turning pages of history in the intro and newspaper headlines bring the history to life.



You can examine units in detail to find out their movement rates, fire-range and armour strength. This display also shows a small digitised photo of the original WWI unit in action, which really sets the atmosphere. Gone are the fantasy sci-fi craft of *Battle Isle*. Instead you're dealing with real history, real technology, and real, fragile people.

A map of the playing area can be called up in the same way. It shows the main depots, factories and headquarters of each of the warring sides. You can check out the overall status of the current campaign and use it to zoom in a specific areas of interest.

Moving units around is easy - you just select the icon shaped like a cross, and this highlights all the spaces where your current unit may move to. Next you position the cursor on the space of your choice, and hit the button again. This highlights the route your

Strategy games are usually accepted as being boring and text-heavy, but *HistoryLine* uses excitement and animation instead.

unit will take, giving you the chance to reject it if, for example, it would take you into range of an enemy gun. When you've decided on your movement, you just click again, and the unit trundles along to the chosen space. You do this with all the units you wish to move, and then select the swap icon. As soon as your opponent has finished his firing phase, he'll select the same icon, and then you just press the F1 function key to switch over.

On the fire phase, things are even simpler. You can go through each unit, using the fist icon to check whether there are any targets in range. Most units can only fire when they are directly adjacent to an enemy unit, but there are some pretty deadly artillery batteries which have a range of up to seven spaces. Other functions can also be carried out during the fire phase, depending on the unit type. Pioneers can be made to dig trenches, and bases can be made to repair damaged units or build new ones, providing you have the energy available.

“ It'll make you think, curse and swear, and breathe plenty of sighs of relief, all in one sitting ”

The core of the game lies in the way you play it - choosing your strategies, blocking your opponents, and trying hard to win battles without destroying all your units in the process. The more they fight, the better they get, and you really get to appreciate what it's like to

lose good men in an appalling battle. *HistoryLine 1914-1918* is a stunner of a wargame, and nothing like the 'specialist interest' sort of affair we normally associate with wargames. It's got masses of appeal, and it should appeal to the masses, even though it's about a particularly miserable portion of 20th century history.

It'll make you think, curse and swear, and breathe plenty of sighs of relief, in one sitting. With first-class animations and wonderfully detailed accounts adding plenty of atmosphere and flavour, you may find you learn a few things. Even if you don't, it's still an unmissable game that's destined to become a classic.

Neil Jackson

HistoryLine 1914 - 1918
Blue Byte ■ £34.99

- A truly brilliant wargame, the like of which we've rarely seen.
- Moody soundtrack, classic animation, and a belter of a game to boot.
- If you can handle chess, *HistoryLine* is a better, 20th Century equivalent.
- Lastability, addictiveness, and mind-bogglingly detailed - it's a winner!
- Chilling and thrilling - don't miss it!



94%

DIGITALLY MASTERED SAMPLES
IFF SOUND SAMPLE LIBRARIES

Each disk is compiled from a **studio quality master** and is sampled on the Amiga at **twice the sample rate of P.D.** sample disks. They are compatible with all P.D. and commercial tracker and sequencer programs. N.B. no. of samples in brackets

001 AFRICAN	Talking drums, Marimbas, chants etc (53)	014 BASS GUITARS	Slap, picked, fretless, FX etc (44)
002 INDIAN INSTR	Sitar, Bansuri, Chants etc (19)	015 ANALOG BASS	Oberheim, Roland, Korg etc (22)
003 INDIAN PERC	Tabla, Bayan, Rhythm Loops etc (35)	016 DIGITAL BASS	Yamaha DX, Roland, Korg etc (28)
004 ARABIC	Ud, Saz, Bendir, Rhythm Loops etc (37)	017 BRASS	Sections, Saxes, Trumpets etc (24)
005 FAR EAST	Tibetan Bells, Yangqin, Koto etc (31)	018 SYNTH BRASS	Analog, Digital & L.A. etc (18)
006 EUROPEAN	Balalaika, Choirs, Bodran etc (34)	019 PIANO	Octave Splits, with strings, FX (16)
007 OCEANIA	Dijendu, Chants, Sit Drum etc (23)	020 STRINGS	Cello, Orch, Hits, Sections etc (21)
008 AMERICAS	Kena, Berimbau, Pan Pipes etc (30)	021 SYNTH STRINGS	Analog & Digital (19)
009 FX PERC	Power Toms, Snarres & Bass, Scratch & Rap (88)	022 CHOIR	Mixed Choirs, with Bells & Synth (16)
010 DRUM KIT	Bass & Snarres, Hi-Hats, Cymbal & Toms (63)	023 ORGANS	Church & Electric (17)
011 ANALOG PERC	TR-808 CR-78, Loops etc (30)	024 BELLS	Real & Synth, with Choir & Strings (20)
012 LATIN PERC	Timbales, Congas, Cabasas, Cowbells etc (107)	025 SOUND FX	Action Sounds, Explosions, Gunshots etc (30)
013 SYNTH PERC	Acoustic, Electric & Distorted etc (41)		

Each disk is priced at £2.50, any 10 for £19.95, the Complete Collection for £49.95. In addition, Sampler owners can use our **Digitally Mastered Chrome, Metal, or DAT sample Cassettes** which contain most of the above samples: **COO1 WORLD MUSIC COLLECTION (175)**
COO2 PERCUSSION COLLECTION (228)
COO3 GUITARS AND BASSES (161)
Each Chrome £9.95, Metal £11.95, DAT £16.95
The Three Collection Package is priced at:
£21.95 (Chrome) £25.95 (Metal), £38.95 (DAT)

P&P £1 (any order) Cheques & P.O.s to:
WALKABOUT MUSIC (Dept AF)
TRENOVISSICK FARM, THE MOUNT. PAR.
CORNWALL PL24 2DA
Tel (0726) 813807

WIN WIN WIN WIN WIN WIN
A SUPER N.E.O. SYSTEM

WE HAVE 10 SUPER N.E.S TO GIVE AWAY
JUST CALL & PLAY ITS EASY & FUN TO PLAY!
0891 446 614
You will be informed of other games & services on line
Calls charged at 38p per min cheap rate 48p per min at all other times. Please make sure that you have the permission of the telephone subscriber before calling. Operated by Bell Audiotex PO BOX 1995 London W11 4EN.

SOCCER KID

ON HIS QUEST TO FIND THE MISSING WORLD CUP SOCCER KID REACHES AN OPERA HOUSE IN ITALY.....



STORYLINE: TIM JAMES

COMING SOON: SOCCER KID. ONLY FROM KRISALIS SOFTWARE

STANHOUSE ENTERTAINMENT

"Home for all your Amiga needs."

* MAIL ORDER ONLY *

MIRACLE PIANO

INCL:-FULL SIZE MIDI
KEYBOARD, SOFTWARE,
LEADS AND MANUALS
ONLY £235.00

COLOUR PRINTERS

STAR:-
LC100.....£169.99
LC200.....£196.99
LC24-200.....£260.00
XB24-200.....£399.99
XB24-250.....£475.00
ZA-200.....£323.00
ZA-250.....£405.00

CITIZEN:-
SWIFT 240C.....£271.99
SWIFT 9 COLOUR.....£189.00
PRODOT 9 COLOUR.....£233.00
224 COLOUR.....£240.00
SWIFT 9X COLOUR.....£253.99
SWIFT 24E COLOUR.....£259.99

**Lots more Printers,
Lasers available.
Ring for Prices**

CONSOLES/HAND HELDS

GAMEBOY + TETRIS.....£65
LYNX + BATMAN RETURNS.....£86.99
GAMEGEAR + SONIC.....£116.00
MEGADRIVE + SONIC.....£112.00

DIGITISERS + SCANNERS

DCTV (PAL).....£366.50
MICROGEN.....£120.00
MINIGEN.....£86.00
ROCGEN GENLOCK.....£86.99
ROCGEN PLUS.....£129.99
ROCGEN ROCKEY.....£242.99
VIDEON.....£120.00
VIDI-AMIGA 12.....£86.99
DAATASCAN PRO.....£129.99
NAKSHA SCANNER.....£101.99
POWER SCANNER.....£82.99
ZYDEC SCANNER.....£95.00

**THIS PAGE
REPRESENTS A VERY
SMALL EXAMPLE OF
THE PRODUCTS
WE SELL**

**PLEASE RING FOR
MORE DETAILS OR A
CATALOGUE**

(0244)382435

SERIOUS SOFTWARE

ACCOUNTS

CASHBOOK COMBO.....£49.99
HOME ACCOUNTS 2.....£34.99
SYSTEM 3E.....£50.00

DATABASE

PRODATA.....£70.00
SUPERBASE PERSONAL.....£43.99

DTP

PAGESETTER 2.....£39.99
PAGESTREAM V2.....£135.99
PRO PAGE V3.....£116.99

WORD PROCESSING

EXCELLENCE V3.....£77.00
KINDWORDS 3.....£35.99
FINAL COPY 2.....£62.99
PROTEXT V5.5.....£107.00
WORDPERFECT V4.....£150.00
WORDWORTH.....£83.00

GRAPHICS

CALLIGARI 2.....£219.99
D PAINT 4.....£56.50
DIRECTOR V2.....£62.99
IMAGINE V2.....£169.00
PRESENTATION MASTER.....£149.99
MORPH PLUS.....£135.00
SHOW MAKER.....£125.00
TAKE 2.....£31.50
VIDEO DIRECTOR.....£92.00
VISTA PRO.....£62.99

VIDEO

BIG ALTERNATIVE SCROLLER.....£32.99
BROADCAST TITLER 2.....£160.00
DELUXE VIDEO 3.....£62.99
SCALA 500.....£69.99

PROGRAMMING

AREXX.....£25.99
DEVPAC 3.....£43.99
LATTICE C V6.....£192.99

MUSIC

BARS + PIPES PRO.....£188.00
COPYIST APPRENTICE.....£67.50
ICCS LEV II 3.5.....£189.99
SUPER JAM.....£67.50
AMAS 2.....£64.00
SEQUENCER ONE.....£14.99
STEREO MASTER.....£25.99
GVP DIGITAL STUDIO.....£43.99

COMPUTERS

A600 WILD, WEIRD & WICKED.....£319.99
A600 HD EPIC PACK.....£449.99
A1200 *NEW***.....£369.99
A1500 BASE PACK.....£544.99
A2000 MULTIMEDIA PACK.....£1030.00
A3000 52MB HD + 2MB.....£1350.00

**FULL COMMODORE PC RANGE AVAILABLE
RING FOR PRICES AND DETAILS**

GVP HARD DISK DRIVES

IMPACT SERIES II HD8+ 52MB.....£320.00
IMPACT SERIES II HD8+ 80MB.....£364.99
IMPACT SERIES II HD8+ 120MB.....£412.00
IMPACT SERIES II HC8+ 52MB.....£265.00
IMPACT SERIES II HC8+ 120MB.....£392.99

3.5" FLOPPY DRIVES

POWER DUAL DRIVE.....£110.00
PC880B.....£62.99
PC880B + CYCLONE.....£85.00
PC880E.....£47.00
ROCLITE DRIVE.....£62.99

CD RANGE

A570 CD ROM DRIVE.....£325.00
CDTV PLAYER.....£458.99
CDTV MULTIMEDIA PACK.....£550.00

**WE BUY & SELL YOUR SECOND
HAND AMIGA'S. RING FOR PRICES**

**All prices correct at time of printing.
Prices may change without notice.**

**All prices include VAT @ 17.5%
Please add postage to your order.**

POSTAGE RATES

Software

**Orders under £100 add £1.50 to your order
Orders over £100 add £2.50 to your order**

Hardware

**Orders under £300 add £4.00 to your order
Orders over £300 add £5.00 to your order**

**Orders combining software & hardware
please use hardware rates.**

Send Cheques/P.O.s payable to

**STANHOUSE ENTERTAINMENT
DEPT AF, 2 UPTON DRIVE, UPTON,
CHESTER CH2 1BU**

TEL: 0244 382435



EAGLE SOFTWARE

118a Palmers Road
New Southgate
LONDON N11 1SL

(10 am - 6 pm 6 days)

Tel: 081-361 2733/5730

(2733 Faxline after 6pm)

CREDIT CARD HOTLINE:

081 889 9172

SPECIAL NEW YEAR OFFER
10% OFF ORDERS OVER £75

TOP TITLES	ST AMIGA	TOP TITLES	ST AMIGA	TOP TITLES	ST AMIGA	TOP TITLES	ST AMIGA
A500+ 1Meg Upgrade.....	N/A £39.99	Crazy Cars III.....	£16.99 £16.99	Hill Street Blues.....	£15.99 £15.99	Monkey Island.....	£15.99 £15.99
A800 1Meg Upgrade + clock.....	N/A £49.99	Cruise for a Corpse.....	£17.99 £17.99	Hol.....	N/A £15.99	Monkey Island II.....	N/A £25.99
0.5 Meg Upgrade + clock.....	N/A £25.99	Curse of the Enchanter.....	N/A £23.99	Home Alone.....	N/A £19.99	Mouse (Switchable).....	£9.99 £9.99
3D Construction Kit II.....	£36.99 £36.99	Cytron.....	£19.99 £19.99	Home Alone Colouring Book.....	N/A £14.99	Myth.....	£18.99 £18.99
3 Stoooges/King of Chicago.....	N/A £8.99	Darkmere.....	£16.99 £16.99	Hook.....	£15.99 £15.99	Navy Seals.....	£9.99 £9.99
4D Sports Boxing.....	N/A £11.99	Das Boot.....	N/A £11.99	Hudson Hawk.....	£8.99 £8.99	N. Mansell World Champ.....	£20.99 £20.99
4D Sports Driving.....	N/A £11.99	Days of Thunder.....	£12.99 £8.99	Humans.....	N/A £19.99	Noddys Playtime.....	£16.99 £16.99
A-Train.....	N/A £23.99	Deliverance.....	£15.99 £15.99	I. Bothams Cricket.....	£19.99 £19.99	Nova Nine.....	N/A £9.99
Action Stations.....	£12.99 £12.99	Desert Strike.....	N/A £16.99	Indy Heat.....	N/A £16.99	ORBITUS.....	£12.99 £12.99
Addams Family.....	£16.99 £16.99	D/Generation.....	£11.99 £11.99	Indy Last Crusade Graphic.....	£8.99 £8.99	Ork.....	£15.99 £15.99
Agony.....	£15.99 £15.99	Disciples of Steel.....	£17.99 £17.99	International Sports Chait.....	£15.99 £15.99	Outlanders*.....	N/A £19.99
Air Support.....	£15.99 £15.99	Doodlebug.....	£18.99 £18.99	Ishar - Legend Fortress.....	£20.99 £20.99	Paperboy II.....	£16.99 £8.99
Aliens III.....	£18.99 £18.99	Double Dragon III.....	£18.99 £18.99	Jack Nicklaus Unlimited Clip.....	N/A £10.99	Parasol Stars.....	£15.99 £15.99
A. Maclean's Pool.....	£16.99 £16.99	Dreadnoughts.....	£22.99 £22.99	Jaguar XJ220.....	£16.99 £16.99	Perfect General.....	N/A £20.99
AMNOS.....	£15.99 £12.99	Dune.....	£19.99 £19.99	Jim Power.....	£16.99 £16.99	PGA Golf Tour.....	N/A £20.99
Amos (Easy).....	N/A £23.99	Dungeom I/Ohnoes.....	£11.99 N/A	J.Khan Squash.....	£8.99 £8.99	PGA Courses Disk.....	N/A £10.99
Amos Com-piler.....	N/A £19.99	Dungeommaster.....	£20.99 £20.99	J. White's Whirlwind.....	£16.99 £16.99	Pinball Dreams.....	N/A £15.99
Amos Professional.....	N/A £54.99	Dyna Blast.....	£12.99 £12.99	J. Barnes (1 Meg).....	£15.99 £15.99	Pinball Dreams II.....	N/A £16.99
Amos The Creator.....	N/A £36.99	Elf.....	£21.99 N/A	J. Madden's Football.....	N/A £18.99	Pitfighter.....	£9.99 £9.99
Another World.....	£17.99 £17.99	Elvira Mistress Dark.....	£23.99 £23.99	Kick Off II (1 Meg).....	£8.99 £8.99	Plotting.....	£6.99 £6.99
Apidge.....	£16.99 £9.99	Elvira II - Cerberus.....	£19.99 £19.99	Kick Off II (5 Meg).....	N/A £14.99	Populus II - The Challenge.....	£11.99 £11.99
Aquatic Games star J Pond.....	£16.99 £16.99	Eye of the Beholder.....	N/A £19.99	Kick Off III.....	£16.99 £16.99	Populus II + (1 Meg).....	£23.99 £23.99
Aventura.....	N/A £13.99	Eye of the Beholder II.....	N/A £23.99	Kid Gloves II.....	£16.99 £16.99	Premiere.....	N/A £20.99
Armourgeddon.....	£15.99 £15.99	F14 Tom Cat*.....	£18.99 £18.99	KILLING GAME SHOW.....	£15.99 £8.99	Prince of Persia.....	£15.99 £15.99
Armourgeddon Upgrade*.....	£10.99 £10.99	F15 Strike Eagle II.....	£23.99 £23.99	Kings Quest V.....	N/A £15.99	Pro Tennis Tour.....	£6.99 £6.99
Ashes of Empire.....	£20.99 £20.99	F177A Stealth Fighter*.....	£21.99 £21.99	Knight Mare + Hint Book.....	£19.99 £19.99	Project X.....	£16.99 £16.99
Assassin.....	N/A £16.99	F19 Stealth Fighter.....	£19.99 £19.99	Knight of the Sky.....	£23.99 £23.99	Push Over.....	£15.99 £15.99
A.T.A.C.....	£23.99 £23.99	F29 Retaliator.....	£15.99 £15.99	Leann Mower Man*.....	£16.99 £16.99	Putty.....	£16.99 £16.99
ATOMINO.....	£8.99 £8.99	Face Off - Ice Hockey.....	£15.99 £15.99	Leander.....	£15.99 £15.99	Puzznic.....	£6.99 £6.99
B17 Flying Fortress*.....	£23.99 £23.99	Falcon Classic Collection.....	£11.99 N/A	Leathal Weapon.....	£16.99 £16.99	QUEST AND GLORY.....	£16.99 £16.99
Bane of the Cosmic Forge.....	N/A £24.99	Falcon.....	£11.99 £11.99	Legend + Hint Book.....	£19.99 £19.99	Railroad Tycoon.....	£23.99 £23.99
BARBARIAN II (Phys).....	£12.99 £14.99	Falcon Mission Disk I.....	£8.99 £8.99	Liege of Kyandia.....	N/A £20.99	Rainbow Islands.....	£6.99 £6.99
Bard's Tale III.....	N/A £8.99	Falcon Mission Disk II.....	£8.99 £8.99	Legends of Valour.....	£25.99 £25.99	R.B.I. 2 Baseball.....	£15.99 £15.99
Bards Tale Trilogy*.....	N/A £19.99	Falcon 3.0*.....	£23.99 £23.99	Leisure Suit Larry I.....	£12.99 N/A	Red Baron.....	N/A £15.99
B.A.T. II.....	£22.99 £22.99	Fantastic Voyage.....	£16.99 £16.99	Leisure Suit Larry II.....	£14.99 £14.99	Red Zone.....	£15.99 £15.99
Battle Chess II.....	N/A £16.99	Fate of Atlantis (Adv).....	N/A £25.99	Leisure Suit Larry III.....	£20.99 £25.99	Rise of the Dragon.....	N/A £15.99
Battle Isle.....	£18.99 £18.99	Fate of Atlantis (Arc).....	£16.99 £16.99	Leisure Suit Larry V.....	N/A £26.99	Risky Woods.....	£16.99 £16.99
Battle Isle Data Disc.....	N/A £13.99	Final Fight.....	£16.99 £16.99	Lemmings.....	£15.99 £15.99	Robin Hood.....	£16.99 £16.99
Battle Toads.....	£16.99 £16.99	Final Fight.....	£16.99 £16.99	Lemmings and Data Disk.....	£15.99 £19.99	Robocop.....	£6.99 £6.99
Big Run.....	£15.99 £12.99	Fire and Ice.....	£15.99 £15.99	Lemmings - Data Disk.....	£21.99 £21.99	Robocop II.....	£6.99 £6.99
Birds of Prey.....	N/A £23.99	First Samu/Megaloman.....	£20.99 £20.99	Lemmings - Stand Alone.....	£15.99 £15.99	Robocop III.....	£16.99 £16.99
Black Crypt.....	N/A £16.99	FireStone HD Scenery.....	N/A £13.99	Life and Death.....	N/A £20.99	Robo Sports.....	N/A £23.99
Blue Max.....	N/A £11.99	Flashback*.....	£16.99 £16.99	Links HD.....	N/A £23.99	Rod Land.....	£16.99 £16.99
Bountiful HD Scenery.....	N/A £11.99	Flight of the Intruder.....	£11.99 £11.99	Liquid Kids*.....	£16.99 £16.99	Rockies*.....	£17.99 £17.99
Back Rogers.....	£19.99 £19.99	Floor 13.....	£19.99 £19.99	Lot Patrol.....	£16.99 £12.99	R-Type II.....	£14.99 £14.99
Back Rogers II.....	N/A £20.99	Football Crazy.....	£14.99 £14.99	Lost Treasures of Incom.....	N/A £29.99	Rugby World Cup.....	£15.99 £15.99
Cadaver.....	£16.99 £11.99	Football Manager III.....	£14.99 £14.99	Lotus Turbo Challenge II.....	£16.99 £16.99	R.V.F. Honda.....	£8.99 £8.99
Cadaver - the pay off.....	£10.99 £10.99	Future Wars.....	£8.99 £8.99	Lotus Turbo Challenge III.....	£16.99 £16.99	Sabre Team.....	£16.99 £16.99
Carl Lewis Challenge.....	£15.99 £15.99	Gauntlet II.....	£16.99 £12.99	Lure of the Tempstress.....	£19.99 £19.99	Savage Empire.....	£22.99 N/A
Castles.....	£16.99 £16.99	Global Effect.....	£16.99 £16.99	M1 Tank Platoon.....	£19.99 £16.99	Secret Silver Blues.....	£21.99 £21.99
Castles Data Disc.....	£11.99 £11.99	Goblins.....	£16.99 £16.99	Magic Pockets.....	£15.99 £15.99	Secret Weap Luft*.....	£19.99 £19.99
Castle of Dr. Brain.....	N/A £15.99	Gods.....	£16.99 £16.99	Man Utd. Europe.....	£15.99 £15.99	Sensible Soccer 92-93.....	£16.99 £16.99
Chaos Engine.....	£16.99 £16.99	Go for Gold.....	£8.99 £8.99	Man Utd. Ultimate Football*.....	£18.99 £18.99	Shadowlands.....	£20.99 £20.99
Chase HQ.....	£6.99 £6.99	Golden Shot.....	£16.99 £16.99	Mega Fortress.....	£16.99 £16.99	SHADOW BEAST II.....	£12.99 £12.99
Chase HQ II.....	£14.99 £14.99	Golden Cricket.....	£21.99 £21.99	Mega Sports.....	£19.99 £16.99	Shadow of the Beast III.....	N/A £19.99
Civilisation.....	£23.99 £23.99	Graham Taylor.....	£15.99 £15.99	Megatraveler II.....	£20.99 £20.99	Shadow Worlds.....	£16.99 £16.99
C.Y.'s Air Combat.....	£20.99 £20.99	Grand Prix (Formula).....	£23.99 £23.99	Merchant Colony.....	£16.99 £16.99	Shoot em up Con. Kit.....	£7.99 £7.99
Codename Ice Man.....	£12.99 N/A	Gunship 2000.....	£21.99 £21.99	Microprose Golf.....	£23.99 £23.99	Shuttle the Sim.....	£20.99 £20.99
Cool Croc Twins.....	£16.99 £16.99	Guy Spy.....	N/A £20.99	Midnight Resistance.....	£6.99 £6.99	Silent Service II.....	£23.99 £23.99
Cool World.....	N/A £16.99	Harpoon (1 Meg).....	£16.99 £16.99	Midwinter.....	£9.99 £9.99	Sim Ant.....	N/A £22.99
Conflict Korea.....	N/A £23.99	Harpoon II.....	£16.99 £16.99	Midwinter II.....	£23.99 £23.99	Sim Earth.....	£23.99 £23.99
Contraptions*.....	N/A £16.99	Harrier Assault AV8B.....	£23.99 £23.99	Mig 29 Fulcrum.....	£16.99 £16.99	Simpsons.....	£15.99 £15.99
Cover Girl Poker.....	N/A £16.99	Heimdal.....	£23.99 £23.99	Might of Magic III.....	N/A £23.99	Simbad/Def of the Crown.....	N/A £8.99
Covenant Action.....	£23.99 £23.99	Hero's Quest (Gem).....	£16.99 £16.99	Moonsong.....	£19.99 £19.99	Sleepwalker*.....	£15.99 £15.99

DREAM TEAM only £16.99 Terminator II, Simpsons, W.W.F.	BITMAP BROS VOL 2 * only £16.99 Xenon II, Speedball II, Gods, Magic Pockets	BITMAP BROTHERS VOL 1 only £16.99 Xenon, Cadaver and Speedball II	NINJA COLLECTION only £13.99 D. Dragon, Shadow Warrior, D. Ninja	RAVING MAD only £18.99 Mega twins, Rodland, Robocod
ACTION 5 only £19.99 Rick Dangerous II, Ghostbusters II, Gunship, Super Ski and Hard Driving	SUPER FIGHTER only £16.99 Pitfighter, W.W.F., Final Fight	SOCCER MANIA only £11.99 Football Manager II, Gazzza's Soccer, Football Manager - W.C. Edition, Microprose Soccer	POWER PACK II only £17.99 Predator II, Battle Master, Wings, It Came From The Desert	FLIGHT COMMAND only £14.99 Eliminator, Strike Force Harrier, Lancaster, Sky Fox and Sky Chase
SPORTS MASTERS only £19.99 PGA Golf Tour +, Indy 500, Advantage Tennis, European Championship 1992	MEGA MDX AMIGA only £19.99 Leander, Agony, Ork	RAINBOW COLLECTION only £13.99 New Zealand Story, Bubble Bobble, Rainbow Islands	COMBAT CLASSICS £20.99 F15 Strike Eagle II, 688 Attack Sub, Team Yankee	AWARD WINNERS only £16.99 Kick Off II, Pipemania, Space Ace and Populus
GRANDSTAND only £11.99 Gazza Super Soccer, Pro Tennis Tour, World Class Leaderboard and Continental Circus	POWER PACK only £14.99 Xenon 2, TV Sports Football, Bloodwych and Lombard Rally	HOLLYWOOD COLLECTION only £16.99 RoboCop, Ghostbusters 2, Indiana Jones, Batman on the Movie	HEAD TO HEAD only £26.99 Mig 29 Super Fulcrum, F19 Stealth Fighter	MAX EXTRA only £17.99 Turrican II, ST Dragon, SWIV and Night Shift
BIG BOX only £15.99 Captain Blood, Tin Tin on the Moon, Safari Guns, Teenage Queen, Bubble Plus, Purple Saturn Days, Krypton Egg, Jumping Jackson, BoBo, Hostages	ACTION PACK only £15.99 Cosmic Pirates, Rotor, Maya, On Safari, Eliminator, Fast Lane, Sheran M4, Hostages, Targlan, Colorado	BIG BOX II only £19.99 Back to the Future II, R-Type, RK+, Real Ghostbusters, Def of the Earth, TV Sports Football, Shanghai, Analytix, Simbad, Bombocool	TEST DRIVE II COLLECTION AMGA only £20.99 Muscle Cars, California Challenge, European Challenge, Duel, Super Cars	STRATEGY MASTER only £21.99 Deuterco, Spookys, Hunter, Chessplayser 2150 and Spirits of Excalibur
4 WHEEL DRIVE only £19.99 Lotus Esprit, Celica GT4 Rally, Team Suzuki and Combo Racer	BOARD GENIUS AMIGA only £17.99 Deluxe Monopoly, Deluxe Scribble, Clevido Master Detective and Risk	CHAMPIONS only £13.99 Jahangir Khan Squash, Man United and Spy who loved me	SUPER HEROES only £17.99 Strider II, Indiana Jones, Last Ninja II and Spy who loved me	2 HOT 2 HANDLE only £16.99 Golden Axe, Total Recall, Shadow Warrior, Super Off Road Racing

VISIT OUR SHOP
AT
120a MYDDLETON ROAD
WOOD GREEN LONDON N22 4NQ.
SHOP PRICES MAY VARY.

Please make cheques and P.O.'s payable to Eagle Software. P&P is £1.00 per item in the UK. Orders under £10 please add 50p per item. Europe: add £3.50 per item. Elsewhere add £4.50 per item. New titles will be sent as released and are subject to manufacturers price reviews. E & O.E. SPECIAL OFFER APPLIES ONLY IF QUOTED WHEN ORDERING.

Computer _____ Date _____
Title _____ Price _____
Price _____
Price _____
Price _____
P & P _____
Total _____

Name: _____
Address: _____
Postcode: _____ Tel: _____
Card No: _____
Exp Date _____ Member No: _____
Access Visa Cheque P.O.'s





It's compilations time folks, with five collections at that bargain-basement price. **Andy Nuttall** wades through and sorts the Ben Eltons from the Bernard Mannings...

Cheap 'n' Cheerful

AMIGA FORMAT

108

FEBRUARY 1993

Bignose the Caveman

CDS ■ £7.99



Aha! At last a game is released which has outsize olfactory regions as its main theme. Fans of Karl Malden will be really happy, because they now have another possible role model in the shape of Bignose, the star of the game. Unfortunately, though, the game is only likely to appeal to the younger generation (who probably won't even know who Mr Malden is anyway). Still, that's life, eh?

Bignose reacts to the marauding 'saurus by beating himself around the head...

Bignose the Caveman is a game of the usual scrolly-runabout-collect-goodies-kill-baddies genre, but

unfortunately it's nothing special. As you would expect the characters are cute and quite large, the music is quite jolly, as are the sound effects, but the gameplay is sadly lacking.

There are plenty of creatures to bash over the head with your club, ranging in size from snakes to dinosaurs, so it's exciting from that point of view. Along the way there are other objects either to collect or bash, and small rocks to pick up which you can use to knock out the larger enemies (such as the brontosaurus in the picture above).

Sometimes it can get a bit annoying, though. For a start it's all too easy to mistime your bash, and end up dead yourself. Jumping over holes is also difficult, because if you jump too near the hole you will end up plunging to your death - and with only three lives, this isn't funny.

OK, it's fun for a short while, and it's more than likely to keep your kiddies amused (and quiet) for a few weeks. And it's only eight quid. Nuff said.

Verdict **65%**

Super All-Stars

Codemasters ■ £25.99

Steg The Slug



Steg's family aren't looking particularly healthy - call the Social Services...

Eleven levels of platform action which pits Steg against all manner of enemies. None of which, curiously, include table salt. Anyway, this is one of the Codey's finest and most original, erm, platform games.

Magiland Dizzy

Dizzy is an egg with several appendages which enable him to walk and hold things. Lucky, because otherwise this would be a bit boring. As it is, it's a playable, egg platformer with cute graphics.

Captain Dynamo

Geriatric fun courtesy of the Captain: leap up levels, collect diamonds and avoid booby traps - was reviewed in Cheap 'n' Cheerful in Issue 40.

CJ In The USA

This is a cute little game, with a tiny elephant for a lead character and many horrid enemies including pit bulls and the Ku Klux Klan. This is another cutesy, nicely executed unoriginal platformer - which was also reviewed in Cheap 'n' Cheerful in Issue 40.

Robin Hood Legend Quest

A curious game for the Codeys, in that it doesn't involve a small, cute character. Instead you control Robin Hood who, instead of robbing the rich and giving to the poor, jumps up and down levels all day. Poor scrolling and reasonable gameplay.

Verdict **75%**

TV Sports Boxing

Mindscape ■ £14.99



Jon, alias Stuart from *Amiga Power*, lets his guard drop for a split second...

Don't worry, this isn't a 'Messrs Carpenter and Bruno engaged in some chirpy repartee' licence - though at least you might have gained some pleasure out of this bout of boxing if it were.

You have to create a boxer by selecting his physical appearance, style and attributes, and then introduce him to the ring where he'll promptly be killed by some big brute with no brain. Be prepared - however good you think you've

made your boxer he'll always get maimed.

The fight begins with an overhead view of the ring, with the two boxers circling each other. As the boxers draw closer together the view switches to a side-on view. Here, your boxer has a hard time touching even the worst opponent, and even when contact is made your boxer makes a far smaller impression than the computer's does.

Although it's well produced (as with all *TV Sports* products) and features some excellent graphics and sound, this isn't a very good game at all. OK, it does have its good points, but the negative aspects of the game far outweigh them. Anyone who does want to get hold of a decent boxing game should try out *4D Sports Boxing* which received a hefty 79 per cent in Issue 30.

Verdict **46%**

TV Sports Baseball

Mindscape ■ £14.99



While nobody's looking, Carl attempts to sneak to third base...

Do you remember Accolade's *Hardball* on the C64? Well, Mindscape are attempting to prove that game technology hasn't moved on at all in the last five years with the release of their *TV Sports* version of the game on their budget label.

Played in a very similar fashion to the aforementioned game, *Baseball* puts you in control of a team from the American leagues, competing in a stadium of your choice. The decor of the stadia doesn't really affect the game of course, but frivolous additions such as this are necessary to show that the Amiga is being used to at least 10 per cent of its full potential.

As it stands, the game isn't that bad at all. The problem is there just isn't enough fun involved in playing it. Control the batting team for a while, and hope that luck's on your side so that you can hit the ball; then move into fielding (where you have a bit more input to the game), and throw the ball around each of your players for a while. Much like *Hardball*, this is fun for a short while when you play against the computer. Competing with a human the fun will last longer as you attempt to make your opponent drop the ball more times than you do. Nice graphics, shame about the playability.

Verdict **65%**

Super Fighter

Ocean ■ £25.99

Pitfighter



West-Side-Story-a-go-go! Just look at that really interesting, er, TV screen...(?)

fighters, but they just look like extras from *West Side Story*. They are animated, but unfortunately they don't change their direction at all – so regardless of where the fight's going on the crowd will always face the same way. This gives the impression they're watching some imaginary fight elsewhere on the screen.

As you walk around, the characters are vertically scaled depending on their position – they get taller as they move nearer the screen. This would be a good feature, except that they look too stretched at the closest point. The only saving grace in the whole game is that there are lots of moves available, so you won't find yourself short of things to do – for the five minutes that you keep the game running, that is.

You control a character who fights in a pit (hence the name), participating in a vicious scrap to the death with your Amiga to see who goes to that great big pit in the sky first. The game consists of some dodgy, jerkily animated fighters wibbling around the screen, wiggling their bums and strutting their trussed-up stuff to the rhythms of an early Eighties-style dance soundtrack.

A crowd of grey-looking people stand around attempting to bait the

WWF Wrestlemania



Ultimate Hero goes for Hulk's throat – more power to him, I say...

when you get to choose your character, the American touches immediately

This game is featured in both the *Super Fighter* and *The Dream Team* compilations so it's bound to be good, isn't it? Well, not exactly. It's not bad compared to *WWF 2* (see Page 64), but it's still not inspiring.

I find the whole concept of WWF a wee bit tedious anyway. Take a few sweaty, overweight individuals with marginal acting ability, stir in some horrible Americanisms, and what's left leaves a bad taste in my mouth.

Even at the start of the game, the American touches immediately

The Dream Team

Ocean ■ £25.99

The Simpsons: Bart vs The Space Mutants



Bart prepares to spray all those nasty purples a delicate shade of red...

going on in true *Simpsons* style, you must guide Bart through five long levels, dodging the aliens and preventing them from reaching the ingredients they require for their Ultimate Weapon. To help you get by, you can collect various implements on the way, such as a spray to change the colour of purple items so that the aliens can't collect them, and a slingshot you can use to shoot balloons for bonuses.

As well as being a reasonable arcade game, a certain amount of thought is necessary in order to complete the puzzles involved. A good game, appealing to the youngsters, and complex enough to keep the more mature gamer amused for a while.

This scrolling platform game, which came free with A500 Plus bundles last year, has proved to be incredibly popular with the younger Amiga owners. The scenario is not unlike many a computer game plot: the Earth has been invaded by horrible purple aliens who are hell-bent on taking over, and Bart has to do all that his little yellow bod can muster to stop them.

After the excellent cartoon-like introduction which explains what's

Final Fight



Cody, having dumped Josh and Todd, prepares for the men-without-brains...

Here's a scrolling beat-em-up which takes place over several areas of downtown Metro City. You take control of Guy, Cody or Haggar, who are a gang of rather large, reasonably well-animated characters intent on finding the evil kidnapers of Haggar's daughter.

As you could probably guess from the accompanying picture, the streets that lie between you and said kidnapers are not peopled with flower-carrying, love-bringing peace-makers. No, all manner of twisted, bitter individuals with steroid-induced biceps and hands that wouldn't look out of place digging up earth on an allotment lie in wait for you to come trundling along.

On your travels through the many scenes, you will find yourself confronted with various enemies from the Mad Gear gang. These include large men who body-check you to the ground, and an American car which sits there threateningly while you smash it up – a similar scene is featured in the later *Streetfighter 2* (see the full review on Page 82).

All in all, not a bad beat-em-up – especially in two-player mode – and the saving grace of this compilation.

Verdict **46%**

appear. Your opponent offers up some throwaway comment such as "You may be big, you may be strong, you may look good, but you just ain't perfect", and you have this uncontrollable urge to scream "Bog off you unimaginative knobwit". Unfortunately, though, that reply isn't one of the available options.

Once you're into the game itself (if you last through the preliminaries long enough without throwing the 'Off' switch), you are presented with the bout between you and the first of five opponents. This involves a couple of large sprites mincing about in a ring, each trying to pin the other to the floor. A reasonable repertoire of moves is available, from leaping off the corners to picking up the chair and hitting your opponent with it, but not enough to save the game from festering in the back of your cupboard after a couple of plays. Ocean's move of including this in two different compilations is just taking hype to an ultimate low.

Terminator 2



Match the two sliding block puzzles to cause the fingers to waggle...

Like *The Simpsons*, this has an excellent film-style introduction which sets a good atmosphere for the game, playing an excellent soundtrack while showing digitised graphics from the trailers for the film.

The game itself is split into eight different sections. The first is a head-to-head beat-em-up where Arnie (you) takes on the T-1000 in an *International Karate*-type scene. You also have a gun to hand as well, which comes in useful for putting the wind up your opponent. Next up comes a *Major Motion*-style level, with Arnie trying to negotiate his way through a vertically scrolling landscape. This is made even more difficult by the fact that the T-1000 is chasing him in a large truck – one of the token scenes from the film.

Possibly the best level, though, shows Arnie's arm with the fingers connected to the wrist via a small sliding-block puzzle. The puzzle must be completed within a set time limit to receive a bonus. As each link is made, the relevant finger wiggles realistically – a nice touch.

Terminator 2 takes its ideas from other games so it is fairly unoriginal, but it has enough variety for the wee 'uns.

Verdict **70%**

Strategy Masters

UBI Soft ■ £32.99

Spirit of Excalibur

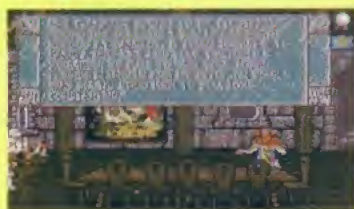

The Knights of the Square Table prepare to do battle...

This is set in England in the year 539, Arthur has been defeated and you play his successor who must defend the realm from marauders.

The game has a *Populous* look, with a map of Britain showing castles and other landmarks. The map may be scrolled to show the rest of the landscape. Reasonable enough game, similar in style to *Defender of the Crown*, which will keep strategy heads happy for hours.

Battle Master

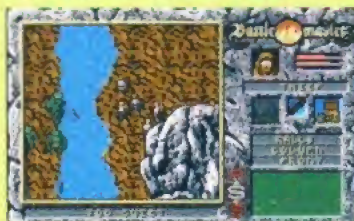

Water repels these green thingummies, but unfortunately not their arrows.

Another strategy game that has some role-playing elements thrown in. Use the mouse to control a small party of characters, each with a role similar to AD&D style games..

Although the sprites are small, and slightly wobbly, the game works well. There's a scrolling landscape through which you can move your characters and info about the current party. A bit dated now but compares favourably with even the latest in the *Ultima* series.

Hunter



Either that's an incredibly large bull, or the 3D scale is a little off...

If you've played *Virtuality* arcade games, you'll know what to expect from this game. The main view is a 3D polygon world through which you must guide your man through several missions. To help him get around no less than 15 vehicles are provided. These are realistically drawn, and have the correct 'feel' as you drive or pilot them. As well as the graphics and playability, the adventure elements are rather good too. Well worth a look.

Chessplayer 2150



Rumour has it that these innocent-looking teddies are involved in a pawn ring.

Five levels of difficulty are on offer, plus a 'learning' option which enables the computer to analyse a game, and learn the moves it considers to be good. So if you're a Grand Master, switch learning on and your opponent's 'intelligence' will grow. Also available are computer vs. computer and human vs human modes.

Verdict **76%**

AMIGA FORMAT

110

FEBRUARY 1993

Populous

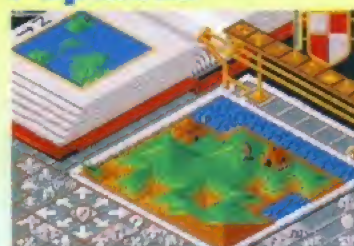

Mavis sneaks stealthily back to her husband, asleep in a nearby hut...

Destroy their enemies, level the land and create new leaders - basically, do

The original god game on the Amiga, and still considered one of the best even though it was updated with the release of *Populous 2* about a year ago. Because of this, UBI Soft have seen fit to include the game on both the *Strategy Masters* and *Fantasy Worlds* compilations featured here.

If you don't know the concept of *Populous* already, you play one of several god-type figures whose aim is to win over the population of an island by being good to them.

everything a good god would do - but always remember that on the next island a rival god is doing a similar thing. It's both a power struggle and a race against time, and only the fittest will survive.

The more popularity you can gain with your people, the more powerful your powers will be. As you gain in strength you will be able to wreak all sorts of mayhem and havoc. Cause floods, earthquakes and battles in neighbouring islands to try to wipe out their population and so beat the other gods into a hollow shell.

The game is represented in isometric 3D and is icon-driven. The main play area is set in the middle of the screen, and this may be scrolled using the set of direction icons on the left side of the screen. Play is represented by tiny, but well-drawn graphics in the landscape. Although it looks a little dated compared to later games such as *Mega-Lo-Mania* and *Populous 2*, it's still very playable and an excellent addition to both of these collections.

Fantastic Worlds

UBI Soft ■ £35.99

Mega-lo-Mania



It's not easy being a god when your land is entirely populated by trees...

In a similar vein to *Populous*, but you're in charge of a race of people. You must speed up their technical development so that they can take over the other islands. Leave them alone and they will reproduce and evolve, but make them go out and discover new minerals and they will make umpteen scientific discoveries.

The game is finely balanced between strategy and arcade styles, featuring superb graphics and excellent sound effects.

Pirates



Yoo-hoo! Don't look down now, but your flies are undone!

An adventure/strategy game where you sail the world, seeking and destroying ships and towns. If you encounter a ship you must engage in combat. If you win you either sink the ship or set it up with your own crew, creating a mini fleet of your own. The graphics are a little dated, as is the sound, but the gameplay is still addictive - proving that if a game plays well, no matter how rusty-looking it is, people will still be playing it for years to come.

Realms



Urrrh! That wall's getting a bit mouldy. Oh no, it's the game map. I see.

Here the aim is to become ruler of eight mythical worlds (though they do resemble Earth). You begin as leader of a single empire and you must tend to your area while plotting to take over the other empires.

The overall game looks similar to *Populous*, but the graphics used to describe the people and cities are just too small to be realistic or cute. Overall, though, it's not a bad game, and great if you fancy a kind of city manager/war gamer-type scenario.

Wonderland



Pretty pictures and animations abound in *Wonderland*.

Based on Lewis Carroll's story *Alice in Wonderland*, the game casts you as Alice and most other characters in the book show up at some point.

The excellent story is backed up by nice still graphics and small animations. It can be played in low, medium or high-resolution modes. Worth it for Alice fans.

Verdict **82%**

Alien Breed Special Edition

Team 17 ■ £10.99



"Shoot, shoot, and then shoot again! Wow, this Marine life can be really fulfilling sometimes." An Alien snuffs it as the guy with the gun looses off another round.

Imagine the scenario: a pair of tough-guy marines wandering about a lonely spacecraft inhabited solely by horrid aliens. Throw in a couple of machine guns, the odd computer or two, and what do you get?

Well, in this particular case you get *Alien Breed '92*, which is an improvement on the original *Alien Breed* game that was released in late 1991. Based loosely on the *Aliens* film theme, the game is in the out-and-out blast-em-out-of-existence genre, with superb 50Hz scrolling backgrounds,

well-animated sprites and some incredibly effective sound effects - including quite a lot of speech.

Your job is to complete several missions, one on each level of the game, such as shooting the four power domes and escaping before the ship is nuked - all pretty good stuff that really gets your adrenaline pumping.

As you rush around the levels, which are very similar in style to Graftgold's *Paradroid '90* in that they are viewed from above, you will find loads of useful items. Keys to open doors (or you can just be darned reckless and blast them open), ammunition for your guns and money in the form of 100 or 1,000 credit bills. Also dotted around the levels are computers which you can log into to gain information or buy new items.

A map of the current level is obtainable, as is loads of new hardware such as guns, lasers, flamethrowers and various tools to get you out of this blast-em-with-anything-you've-got-em-up. These generally weigh in at a large number of credits, though, so it's a good idea to build up a good wallet-ful so that you can go for the more effective firepower.

If you've managed to play the original *Alien Breed*, then you're not likely to be stunned by the additional features of the new version - except for the extra levels (double the original amount) they are quite subtle. As well as ironing out the flaws in the original, the authors have made the aliens tougher, improved the storyline, tweeked the game maps and included a password system so that you can return to the level you were just killed on (which is a useful feature, believe me).

One thing they haven't got around to doing, however, is changing the proximity-detection of doors. If you find a narrow corridor with two doors on either side, you can't get past without opening at least one of them - because the program detects your position, not your direction. Still, this is only a minor niggle.

For those of you who haven't played the original, and if you enjoy a good shoot-em-up, they don't come much better than this. If you do already have the game, I would still advise you to think seriously about getting this version - it really is quite a lot better, and really a snip at only 11 quid. Buy it now or buy it later.

Raving Mad

US Gold ■ £25.99

Rodland



Cutey Tam prepares to perform another Karate move on an unsuspecting enemy.

With 44 levels of action, *Rodland* proved to be a gem of a game in the arcades. This conversion remains true to the original, and even goes so far as to add in some features. Using the popular screen-by-screen approach, as used by *Bubble Bobble* and many others, *Rodland* offers up Tam and Rit as the two main characters. As you may have guessed, the two stars are very cute-looking, as are the rest of the graphics, with even the most vicious of monsters depicted as a fluffy pet thingy.

Each level has lots of goodies to pick up, hazards to dodge and Tam has an excellent way of knocking the badies into a cocked hat for a bonus. Playable, addictive and attractive.

James Pond - Robocod



James with his amazing expand-o-suit leaps and bounds between platforms...

Although the original *James Pond* game was merely a platformer, this sequel is more of a console-style game in which you run and jump about multi-scrolling levels, and dodge some cute, smiling baddies. Wearing a specially designed suit, which enables James to become like Stretch Armstrong or retreat into his body armour at will, you must traverse the levels to finally defeat the evil Dr Maybe.

Beware, though, if you don't have

a sense of humour (not that you're likely to admit this) - *Robocod* is packed with some of the most atrociously groan-worthy fish-type puns you're ever likely to see in an Amiga game. Cod they were awful.

If you're a fan of arcade games, and you haven't got a copy of *Robocod* yet, then you're either in prison or seriously deranged (or maybe both). In most people's carefully considered opinion, this is one of the best games of all time - and this still stands now, a year after its original release.

Mega Twins



Not as fluffy wuffy, cutesy wutesy as the other two in the pack.

In almost all multi-game compilations there has to be at least one bogey, and - sadly - the one in this case has to be *Mega Twins*. You can see why it's included, though - because it's yet another game where you have to run across platforms and collect things, while bashing cute-nasties with your sword. In the playability stakes it's not that bad; and although it's got the cutesy graphics that the rest of the pack have, it just doesn't make the grade that is set by the other two

games in the collection. There isn't much of a hook to get you interested, and once you do work up some enthusiasm, it'll soon evaporate.

OK, so it's not a game to buy on its own, but it does make a nice addition to the pack, and you will find yourself coming back to it from time to time.

By the way...

This pack comes with a free Kixx game - in our case it's *Action Fighter*. Remember the age-old arcade game *Super Spy* from Sega, where you had to drive a car up a busy motorway, dodging innocents and nobbling the baddy spies? This is a reasonable version of that game, which isn't too great - but it's free so who's complaining?

See what's new for the Amiga

Come and find out what's new and pick up show bargains at the same time.

Music, Business, Education, Games

Pre-Purchase your fast lane tickets by 12th February to save money and avoid the queues.

Ticket prices on the door: £6

Under 10's, Students, OAPs and unemployed: £4 (identification required)

In advance: £5 and Under 10's: £3

THE 7th International COMPUTER SHOW



WEMBLEY
VENUE OF LEGENDS

Sponsored by:



19, 20 & 21 February 1993

Wembley Conference and Exhibition Centre, Hall 1
Nearest Tube station - Wembley Park (Metropolitan and Jubilee Lines)
3000 car parking spaces

Major feature areas including Virtual Reality, Electronic Music and The Home Office, Competitions, Advice centres and terrific bargains. Also on show - products for PC, Acorn, Atari machines and games consoles

Westminster
EXHIBITIONS

To: International Computer Show, PO Box 68, St. Austell PL25 4YB

Please send me _____ Fast Lane Tickets @ £5.
_____ Under 10's Fast Lane Tickets @ £3

I enclose a cheque / P.O. / Credit card details for £ _____ made payable to International Computer Show

Name _____

Address _____

Postcode _____

Credit Card No. _____ Expiry date _____

OR phone 0726 68020 to book with credit card



Westminster Exhibitions Limited, Surrey House, 34 Eden St., Kingston, Surrey KT1 1ER

All trademarks and tradenames are the property of the respective manufacturers

Ticket hotline:
0726
68020

The **AMIGA** Collection
FORMAT

No.7 RRP £40

Devpac 2
From HiSoft

COMPLETE PROGRAMMING PACKAGE!
Take some tips from Populous II creators Bullfrog as they tutor you to games-writing prowess with this fully-featured machine code package. Go on, beat the softies at their own games!

● A 500 Plus Compatible ● 1Mb Recommended ●

Your Turn! Part 5

How to program your own games in assembler

If you've been following the Bullfrog's programming tutorial over the last few issues, your game will be ready for the finishing touches. Read on as the boys (pictured above) explain what to do...

Welcome to the fifth and final part of our series teaching you how to program games using the professional techniques of the Bullfrog programming team. This month, **Scott Johnston** explains how to add some finishing touches and tweaks to the game, and how you could take it further when it comes to starting out on your own games.

This is the last issue in our assembly programming series, and since the demo could almost be considered a 'proper' game, this month we will concentrate on enhancements – some simple, and others not quite so simple.

SOME SIMPLE CHANGES

The following changes are really tweaks to the equates we set up. The main problem with the game is the massive momentum we have on our guy. Way too much. What you can do is alter the variables:

MAX_SPEED, used to increase or decrease the speed at which you move.
ACCEL, the amount your man changes speed by when you move the joystick.

SLOW_DOWN, the speed at which you slow down when not moving the joystick.

JUMP, how far your man can jump, works in relation to **GRAVITY**.

GRAVITY, how quickly you will fall back to earth.

MAX_FALL, how far you can fall before suffering from a case of terminal death.

NO_LIVES, the actual number of lives that you have.

If you think that the collision is a bit dodgy, change the man's width, or the bad guy's width. To make it harder to die, change **MAN_WIDTH** to a smaller number: the smaller, the harder for you to touch something.

Continued overleaf

If you find it a bit difficult to stand on the platforms you can change the size of your feet: reduce the left foot, and increase the right foot. This will make it easier for you to stand on the platforms, but might have the strange visual effect of standing in mid-air.

If you run the version given away on this month's disk, you will see that a simple title screen is present. This was created with the code inside the routine `intro.s`, and was called at the start of `display.s`. You can do what you will with this code.

There is also a very simple 'Game over' display. At present only the highest score is coded. It will be quite a good exercise for you to change the routine that is present to that of a high-score table with names for the places.

Another thing for you to do is to try a code a delay. If you press the fire button for too long when you start, the first thing you will do is jump into the air. Similarly, when you have finished playing if you press fire at the end screen there is a chance of you going right past the introduction screen!

Collection Bonus

You may have noticed that the ankhs have a state defined for them: change the code so that if you pick up an ankh which has a different state, then you get double score or something similar. The graphics for a flashing ankh are also included in the file for this month's program listing, so give that a go.



Screen display

This is the slowest part of the program at present. It is drawn forwards at present: the data is stored consecutively, and is copied from memory to screen. Try storing the bytes as blocks of 48 (the amount we pick up inside the loop) but store them backwards. The bottom 48 bytes of the screen are stored as the 1st forty eight bytes of memory, so we can change the (a1) to a -(a1) and hence we would not need the lea command to adjust the address in a1. The quickest way would be to use the blitter chip, but it's too complex to explain here.

Speed

At present the whole screen is redrawn every turn. This is a large waste of time, in that there are only four or so sprites being updated at a time. If you change the system to a redraw, you will need to store a copy of the background that the sprites are about to be drawn onto. Then at the start of the turn, redraw the

Here it is - the final Bullfrog demo game, running and jumping with collision detection, a sound track and a scoring system.

background, and then draw the new sprite positions. You should be able to get the system running at a 50th of a second very easily with this system.

Preshifted graphics

If this seems like too much work for you, then try using preshifted sprites. This is basically 16 copies of all the graphics, one at each possible shift position. These pre-shifted sprites are very quick to draw but take up over sixteen times the memory. Even with the limited graphics it will still involve a lot of work.

Organised palette

Having the palette in a specific order has some advantages. For instance, the font is an example of this, as is the bouncing logo, both are only drawn into a single plane.

There are of course loads of other little tricks that you could do to speed up this program, for example place all the drawing routines into the blitter. I am not going to tell you how to do all this for various reasons.

For starters, we do have to have *some* trade secrets! On top of that, they're mostly just little fixes and shortcuts we discovered when trying to solve a particular problem.

All the same, we think you've got enough to be going on with. This series should at any rate get you started in 68000 programming - the rest is up to you!

USE YOUR OWN GRAPHICS

Well, we finally got the *DPaint-to-Sprite Convert* program from the Bullfrogs, and just to make it as available to people as possible, it has been included on both Coverdisks - so if one has a read/write error, it can still be used from the other Coverdisk. Incidentally, if any of your Coverdisks don't work, you should send them back to the address at the bottom of the "Backing Up Your Coverdisk" bit on Page 10.

The *Convert* program is a handy utility for taking pictures done with a paint package like *Deluxe Paint* and transferring them into raw binary that can be included from within a *Devpac* listing using the `Incbin` (Include Binary) command. There are many examples of this function embedded in the demo code, so have a good ponder to see just how it's done. *Convert* can handle whole screens or those split up into a grid so you can use it for your background screens as well as your sprites.

Getting at it is not too much of a chore, but is not immediately obvious. What you have to do is boot either Coverdisk (insert it into a freshly reset Amiga) and hold down the `Ctrl` and `D` keys. The startup-sequence will abort, and you will be left with a little `CLI` or `Shell` prompt to type at. Just type this and press the `Return` key (always press `Return` after typing `Shell` or `CLI` commands):

```
Convert
```

The program will run, and ask you for four answers. The first thing it needs to know is the path and filename of the picture that

you want to change into binary code. Just typing in the name will not be enough - for instance, if you had a picture called `Mypic.IFF` on a disk called `Empty`, you would type in:

```
Empty:Mypic.IFF
```

Next you have to type the path and name of the data file that the *Convert* program produces. So if you want to put the binary file onto a disk called `Devpac2`, in a directory called `Data`, with a name of `Mydata.BIN`, you would type something like

```
Devpac2:Data/Mydata.BIN
```

The penultimate thing you have to type is the height of the graphics in pixels. If your sprites are, say, 32 pixels high, then type 32. If you want to do a whole screen (200 or 256 pixels high) just type the number. Don't forget to press `Return`.

Then type the width of each pixel block - again, the smaller the width, the bigger the number of blocks that the graphics will end up in. Check out the illustration for a couple more insights.

Please do not think that *Convert* is the only program that can get your graphics into raw code. There are many similar programs available, many of which are used by Public Domain coding groups like *Kefren's*, *Rebels*, *LSD* and many more. Some of them are better than this *convert* program (*Kefren's Metallon Utilities* are especially good, if incompatible with *Workbench 2*) and some aren't, but they all do the same job.

GETTING AT THE CODE

As usual, the code is not in a usable form straight from the Coverdisk - but it's really easy to get it onto your *Devpac* disk. Incidentally, many readers get worried that they need every single tutorial. This isn't true. So long as you have a copy of the *Devpac* disk from *Amiga Format* issue 39, you can use any of the demo code on its own.

Anyway, to get the code on to your disk all you have to do is switch on your Amiga and load *Workbench*. Once the drive light has gone out and you are left at the *Workbench* screen, pop in the *Prodata* disk and double-click on its icon. You will see an icon labelled `Install_Bullfrog_Files`. Double-click on this, and insert the *Devpac2* disk when the machine asks for it. You shouldn't have to swap disks more than once or twice at the very most (though this depends on your *Workbench* version).

Some people have asked how they install the files onto a blank disk, rather than the actual *Devpac2* disk. The easiest way to do this is to format a blank disk, and call it *Devpac2*. Go through the above procedure, and instead of the real *Devpac2* disk, put your blank in. Then rename the disk to whatever you want. Simple eh!

OVER TO YOU

There has been a tremendous response to the Bullfrog programming series, yet this is the end of it. However, everybody wants more code! More examples, more tutorials, more techniques, more tricks, more things to avoid. So we are going to continue printing material on machine code and putting source code on the Coverdisk - provided we keep receiving suitable material.

There are two ways in which you can help. The first is by writing in to us and asking for whatever kind of stuff you want to see - we have a good idea of the sorts of routines and demos you want, but the more requests we get for a particular subject, the more chance we'll cover it.

The other way you can help is to send in suitable material - source, examples, questions and answers. Again, we already have some material to keep the series going - but we need more all the time. Programming was the subject which most people wanted to see more of in the magazine when we asked six months ago, so if you still want to see more, please help us. Send in your requests and submissions to; *Devpac Continued*, *Amiga Format*, 30 Monmouth St, Bath BA1 2BW, UK.

ROMFORD COMPUTER CENTRE

THE NEWEST NAME IN SOFTWARE MAIL ORDER:
PLEASE SEND CHEQUES/PO/ACCESS/VISA NO AND EXPIRY DATE TO: ROMFORD COMPUTER CENTRE, 72 NORTH STREET, ROMFORD RM11DA.
POST & PACKING INCLUDED EXCEPT NON-EEC COUNTRIES. PLEASE ADD £5.00 PER ORDER FOR AIR MAIL.
TELEPHONE ORDERS: 0708-735006/7.
CALLERS WELCOME MON TO SAT 10AM - 4PM

AMIGA	OUR PRICE	AMIGA	OUR PRICE	AMIGA	OUR PRICE	AMIGA	OUR PRICE
3D Con Kit II	29.99	Dynablasters	19.99	Legends of Valour	22.99	WWF2	16.99
A-Train	22.99	Epic	16.99	Lemmings	14.99	Wing Commander	22.99
A320 Airbus	22.99	Eye of Beholder	19.99	Lethal Weapon	19.99	Wizkid	16.99
AVBB Harrier Assault	22.99	Eye of Beholder 2	22.99	Lionheart	19.99	Zool	14.99
Addams Family	16.99	Falcon 3	24.99	Lotus Challenge 3	14.99	LEMMINGS 2 ...£19.99	
Air Warrior	19.99	Fantastic Worlds	22.99	Lure of Temptress	19.99	WORD PROCESSING:-	
Alien 3	19.99	Fatal Strokes	19.99	Megatraveller 1	10.99	Excellence 3.0	56.99
Alien Breed '92	8.99	Fire Force	15.99	Megatraveller 2	19.99	Kindwords 3.0	36.99
Amos	32.99	Fire & Ice	16.99	Mini Office	39.99	Penpal	51.99
Amos Professional	44.99	Flight of Intruder	9.99	Myth	16.99	Protex 5.5	94.99
Aquatic Games	17.99	Football Director 2	16.99	Nigel Mansell W. Champ	16.99	Quickwrite	28.99
Archer Maclean Pool	19.99	Football Manager 3	14.99	No Second Prize	19.99	Scribble (Platinum)	26.99
Arsenal FC	16.99	Football Crazy	14.99	PGA Tour Golf +	19.99	Wordworth 1.1	79.99
Assassin	16.99	Formula One GP	22.99	Parasol Stars	16.99	Word Perfect 4.1	139.99
B17 Flying Fortress	22.99	Frontier (Elite 2)	22.99	Pathway to Power	19.99	SPREADSHEETS:-	
Bills Tomato Game	21.99	Fuzzball	7.99	Pinball Dreams	16.99	Advantage	69.99
Birds of Prey	22.99	Gadget Twins	16.99	Piracy	19.99	Maxiplan 4.0	34.99
Black Crypt	16.99	Goblins	16.99	Premiere	16.99	ACCOUNTING:-	
Board Genius	19.99	Gunship 2000	22.99	Push Over	16.99	Arena Accounts	79.99
Bunny Bricks	16.99	Guy Spy	18.99	Ragnarok	19.99	Home Accounts 2	39.99
Champ Manager	16.99	Harpoon	22.99	Railroad Tycoon	22.99	Per Finance Man	24.99
Chaos Engine	16.99	Heimdall	12.99	Rampart	16.99	BUNDLES:-	
Chuck Rock 2	14.99	Home Alone	16.99	Road Rash	19.99	Compendium 6	29.99
Civilization	22.99	Humans	18.99	Secret of Monkey Isle	17.99	Works Platinum	59.99
Cool Croc Twins	10.99	Indy Jones Atlantis-		Secret of Monkey Isle 2	24.99	PROGRAMMING:-	
Combat Air Patrol	21.99	Action Game	19.99	Sensible Soccer	16.99	Amos the Creator	32.99
Covert Action	22.99	Adventure	19.99	Sensible Soccer 2	16.99	Amos 3D	22.99
Crazy Cars 3	16.99	Int. Rugby Challenge	17.99	Shadow of Beast III	21.99	Amos Compiler	19.99
Creatures	16.99	Jaguar XJ220	14.99	Silly Putty	16.99		
Curse of Enchantia	16.99	Jimmy Whites Snooker	16.99	Streetfighter II	19.99		
Desert Strike	19.99	John Madden Football	16.99	Team Yankee	10.99		
Doodlebug	14.99	KGB	23.99	The Manager	19.99		
Dune	19.99	Kick Off 3	16.99	Undrium 2	17.99		
Dungeon Master & Chaos	21.99	Legend of Kyrandia	21.99				

AMIGAのプロショップだ!

A600 NTSC V2.04 74,000	A500 NTSC V1.3 68,000	A3000 TOWER/040 200MB/5MB 468,000	A2000 V2.04 + ECS 139,000
A600HD NTSC (40MB) V2.04 98,000	A600HD NTSC (80MB) V2.04 119,000	A3000 120MB/5MB 294,000	A4000 V3.0 HD/120MB 468,000

GRAPHICS

SCENERY ANIMATOR 14,900
DELUXE PAINT 4 21,800
IMAGINE 2 49,600
BUDDY SYSTEM FOR IMAGINE 9,800

VIDEO

IMPACT VISION 24 298,000
VIDEO TOASTER V2.0 328,000
PERSONAL TBC III 148,000
VIDI-AMIGA12 NTSC 24,900

HARD DISK

GVP 4MB/4MB SCSI CONTROLLER 400 56,000
GVP 52MB/4MB 98,000
GVP 64 SCSI CONTROLLER A200/A3000 30,000
GVP 52MB/4MB A2000 69,000
GVP 120MB/4MB A2000 98,000
GVP 200MB/4MB A2000 148,000
GVP ACCELERATOR/HARD DISK COMBO 22,000

GAMES (ALL NEW, PAL VERSION)

EPIC 5,900
PINBALL FANTASY 5,900
TRODDERS 5,900
PINBALL DREAMS 5,800
LOTUS III FINAL CHALLENGE 6,200
BEAST III 5,900
JAGUAR XJ220 5,400
ASSASSIN 5,900
ZOO 4,900
DOJO DAN 4,900
ROBOCOP 3 4,900

EMULATOR

AMAX II PLUS W/O ROM 57,900
ROM FOR AMAX II PLUS 34,900
EMPLANT 22,000
386SX AT-BRIDGE BOARD 119,000

LANGUAGE

EASY AMOS 9,500
SAS/C/LATICE/C.V5.1 35,500

100%ユーザーサポート

ACCELERATOR

VXL30 25MHz A500/A2000 69,000
VXL32 2MB RAM FOR VXL30 44,800
PAL UPGRADE KIT 19,800
68030 50MHz CPU 26,000
3.25MHz TURBO MEMO 8MB/16MB/32MB 34,900
ADSPLEED 14MHz A500 32,900
ZEUS 04028MHz/SCSI II A2000 298,000

PERIPHERALS ETC...

1.5 Meg Upgrade £75.00
5.25 Drive £70.00
3.25 1 Meg Drive £49.00
Amiga Mouse £30.00
Upgrade with clock £32.00
Upgrade without clock £24.00
Amiga Power Supply £24.00
Trackball Mouse £38.00
Drive Cleaners £2.00
Mouse Mats £2.00
Disks £0.40
Labels £1 ea.

激安ゲーム在庫豊富 続々入荷!

店頭・通販 a beautiful amiga life for you
輸入直販 システムコンパック 木曜定休

〒110 東京都台東区台東4-22-10
中層ビル3階
TEL: 03-3837-8689



YEW TREE LEISURE

Mail Order supplies

COMPUTER AND VIDEO GAME SPECIALISTS

AMIGA PUBLIC DOMAIN 99p

AMIGA PUBLIC DOMAIN FISH DISKS UP TO 720 99p
DEJA VU UP TO 85 £3.99
LARGE RANGE OF T-BAG 99p

Large range of PD in stock new titles arriving daily from all over the world. Tell us your interest, games Demos etc and we will fill your disk up.

GAMES UNLIMITED

Far too many titles to list, hundreds of clearance titles between £1-£5
Winter Clearance all at £5 each
9 Lives
Badlands
Cadaver
Challenge Golf
Days of Thunder
Die Hard 2
Flames of Freedom
Golden Axe
Hudson Hawk
Inter Phase
Midwinter
Radio Control Race
Smash TV
Wings
Xenon 2
Zork 3

MANY MORE AVAILABLE INCLUDING LATEST RELEASES ETC.

PERIPHERALS ETC...

1.5 Meg Upgrade £75.00
5.25 Drive £70.00
3.25 1 Meg Drive £49.00
Amiga Mouse £30.00
Upgrade with clock £32.00
Upgrade without clock £24.00
Amiga Power Supply £24.00
Trackball Mouse £38.00
Drive Cleaners £2.00
Mouse Mats £2.00
Disks £0.40
Labels £1 ea.

Disks - phone for bulk price

GAMES MACHINES ETC...

We stock Megadrive, Master System, Nintendo etc. Machines and have a large range of games to date at very competitive prices.
Joysticks, converters, control pads carry cases etc....

Phone or write for list of stock & prices.

Andy Townsend
84 Yew Tree Road
Attleborough,
Norfolk NR17 2RD
Phone/Fax: 0953 452803
Mobile: 0860 458958

SORRY NO PERSONAL CALLERS

AMAGRE PRICES FOR AMIGA USERS

3D Construction Kit 2	33.95	Dizzy's Excellent Adventures	17.95	Legend	20.95	Robocop III	17.95
4 Wheel Drive (Comp)	20.95	Doodlebug	17.95	Legend of Kyrandia (1Mb)	23.95	Robocop	20.95
A10 Tank Killer (1Mb)	23.95	Double Dragon II	7.95	Leisure Sun Larry 5 (1Mb)	23.95	Rockland	17.95
Addams Family	17.95	Double Dragon III	17.95	Lemmings (Original)	17.95	Rolling Runny (N*)	17.95
AD1 English (11-12)	17.95	Dreaming	25.95	Lemmings 2	17.95	Sabre Teatr (1Mb)	17.95
AD1 English (13-14)	17.95	Dream Team	17.95	Lemmings Double Pack	20.95	Savage	7.95
AD1 French (14-15)	17.95	Duke (1Mb)	20.95	Lemmings Levels (Add-On version)	13.95	Scrabble	13.95
AD1 Maths (11-12)	17.95	Dungeon Master/Chaos Strikes Back (1Mb)	20.95	Lemmings Levels (Stand Alone)	17.95	Secret of Monkey Island (1Mb, N*)	17.95
AD1 Maths (13-14)	17.95	Dyna Blaster	20.95	Lethal Weapon	17.95	Secret of Monkey Island II (1Mb)	26.95
Advanced Destroyer Sim	7.95	Easy Amos (1Mb)	25.99	Let's Spell At Home	14.95	Secret of Silver Blades (1Mb)	20.95
Advanced Fruit Machine	5.95	Evva 1 (1Mb, N*)	20.95	Let's Spell At The Shops	14.95	Sensible Soccer 92-93	17.95
Air Bucks (1Mb)	20.95	Emily Hughes International Soccer	23.95	Life & Death	12.95	Shadow of the Beast II	20.95
Air Combat Aces (N*)	20.95	Epic (1Mb, N600)	20.95	Links (1Mb)	23.95	Shadowlands	20.95
Air Sea Supremacy (Comp)	20.95	Escape from Planet of Robot Monsters	6.95	Liverpool Football	17.95	Shadows (1Mb)	17.95
Air Support	20.95	España - The Games 92	17.95	Locomotion	17.95	Sherman M4 (N600)	6.95
Air-Land-Sea (Comp) (888 AS N*)	23.95	Euro Football Champ	20.95	Lombard RAC Rally	6.95	Shoe People	17.95
Alcatraz	17.95	Exile	17.95	Lord of the Rings	17.95	Shoot 'Em Up Construction Kit	7.95
Alan 3	20.95	Eye of the Beholder I (1Mb)	17.95	Lotus Esprit Turbo Challenge	7.95	Shopping Basket	13.95
Alien Breed - Special Edition 92 (1Mb)	8.95	Eye of the Beholder II (1Mb)	20.95	Lotus III - The Ultimate Challenge	17.95	Shuttle (1Mb)	20.95
Altered Beast	13.95	F 16 Combat Pilot	7.95	Lotus Turbo Challenge II	17.95	Silent Service II (1Mb)	23.95
Alvina Pursues	9.95	F 19 Stealth Fighter	20.95	Lure of the Temptress (1Mb)	20.95	Silkworm	7.95
Amberstar (1Mb, N600)	20.95	F 29 Retaliator (N*)	17.95	M1 Tank Platoon	20.95	Sim Ant	23.95
Amos 3D	23.95	Falcon	11.95	Magia Maths (4-8)	19.95	Sim City	18.95
Amos Compiler	20.95	Falcon - Counterstrike Data Disk	7.95	Magia Storybook (1Mb)	20.95	Sim City - Architecture 1	7.95
Amos Professional (1Mb)	46.95	Falcon - Firefight Data Disk	7.95	Magia Worlds	17.95	Sim City - Architecture 2	7.95
Amos the Creator	33.95	Fantastic Worlds (Comp)	23.95	Magiandand Dizzy	6.95	Sim City - Terrain Editor	7.95
Anarchy	17.95	Fantasy World Dizzy (N*)	5.95	Manchester United	7.95	Sim City/Populous	20.95
Apocalypse World	17.95	Facination	5.95	Manchester United Europe	17.95	Sim Earth	23.95
Answer Back Junior Quiz (6-11)	15.99	Fast Food (N*)	5.95	Matus Adventure (6-14)	19.95	Sk of Die	8.95
Answer Back Senior Quiz (12-Adult)	15.99	Fire and Ice	17.95	Matus Dragons	10.95	Snow Bros	17.95
Answer Back - Arithmetic (6-11)	8.95	Fire Force	17.95	Max (Comp) (N*)	20.95	Soccer Pinball	6.95
Answer Back - World Geography (11-AD)	8.95	First Division Manager	6.95	McDonald Land	17.95	Soccer Stars (Comp)	17.95
Apsdy	17.95	Flight of the Intruder	12.95	Mega Mix (Comp)	20.95	Sooty & Sweep	6.95
Aquatic Games	17.95	Flambo's Quest	7.95	Mega Sports	17.95	Space Ace II	23.95
Aquavivendi	17.95	Floor 12 (1Mb)	20.95	Mega Twips	20.95	Space Cruise	20.95
Archer Maclean Pool	17.95	Football Crazy (Comp)	17.95	Mega 10-Mania/First Samurai	20.95	Space Gun	17.95
Arkandol II - Revenge of Doh	6.95	Football Director 2 (1Mb, N*)	17.95	Megaforaster (1Mb)	20.95	Spanish Tutor	15.99
Armour Gaddan 2	17.95	Formula 1 Grand Prix (1Mb)	23.95	Megatraveller 1 (1Mb)	20.95	Special Forces (1Mb, N600)	23.95
Arsenal - The Computer Game	17.95	Fracton Goblins	10.95	Megatraveller 2 (1Mb)	20.95	Spelling Fair (7-13)	17.95
Assassin (1Mb)	17.95	French Mistress	15.99	Mercenary 3	17.95	Sports Best	17.95
Award Winners (Comp)	17.95	Fun School 2 (6-8)	6.95	Merlin's Maths (7-11)	17.95	Stag the Slug	6.95
Bane of the Cosmic Forge (1Mb)	25.99	Fun School 2 (over 8)	6.95	Micro Man (Beginners - GCSE)	18.95	Stellar 7	17.95
Barbarian I	8.95	Fun School 2 (under 6)	6.95	Micro Man (Beginners - GCSE Business)	20.95	Storm Master	20.95
Barbarian II (Budget)	6.95	Fun School 4 (5-7)	17.95	Micro Man (N*)	23.95	Strategy Masters	21.95
Bards Tale 1	8.95	Fun School 4 (7-11)	17.95	Mig 29 Soviet Fighter (N*)	5.95	Street Fighter (N*)	7.95
Bards Tale Trilogy	23.95	Future Wars	10.95	Might and Magic III (1Mb)	23.95	Street Fighter 2	19.95
Bat 2	23.95	G-Loc	17.95	Mini Office (1Mb)	49.95	Strider	6.95
Batman - Caped Crusader	6.95	Gateway to Savage Frontier (1Mb)	21.95	Moonbase (1Mb)	20.95	Strider 2	7.95
Batman The Movie	6.95	Gauntlet II	6.95	Moonwalker (N*)	6.95	Strike Fleet	17.95
Battle Chess	6.95	Gauntlet III	17.95	Motorhead	12.95	Striker (1Mb)	17.95
Battle Isle	13.95	German Masters	15.99	Myth	17.95	Stunt Car Races	6.95
Battle Isle - Scenario Disk Vol 1	13.95	Ghosts of Borneo 2 (N*)	6.95	Narc	17.95	Supaplex	6.95
Battle of Britain	20.95	Ghouls 'N' Ghosts	6.95	Narco Police	6.95	Super Frog (1Mb)	17.95
Battle Toads	17.95	Global Effect (1Mb)	20.95	Neighbours	17.95	Super Monaco GP	7.95
Battlehawk 1942	12.95	Goome Alone	17.95	New Zealand Story (N*)	6.95	Super Off Road	7.95
Beach Volley	6.95	Goblins	17.95	Nigel Mansell's World Championship	20.95	Super Sam Pack (Comp)	18.95
Beastbusters	17.95	Goblins 2	17.95	Ninja Collection	13.95	Super Space Invaders (N*)	17.95
Better Spelling (8 Adult)	19.95	Gods	17.95	Ninja Warriors	7.95	Super Tetris (1Mb)	20.95
Big Run	17.95	Golden Axe	7.95	No Greater Glory	23.95	Supercats	6.95
Birds of Prey (1Mb)	23.95	Graham Taylor's Soccer (1Mb)	17.95	Non-Squared Pizza (N600)	17.95	Supercars II	6.95
Bitmap Brothers - Volume 1	17.95	Grandstand (Comp) (N*)	17.95	Noah's Playtime (1Mb)	17.95	Superfighters (Comp)	17.95
Bitmap Brothers - Volume 2	17.95	Gunship 2000	23.95	North & South	6.95	Superaki 2	17.95
Black Crisp (1Mb, N*)	17.95	Guy Spy	20.95	Omar Sharif's Bridge (1Mb)	23.95	Suspicious Cargo	17.95
Body Blows (1Mb)	17.95	Hagar the Horrible	15.95	Operation Combat	7.95	Switchblade II	7.95
Brain Blaster	6.95	Harlequin	17.95	Operation Thunderbolt	6.95	Swiv	7.95
Bubble Bobble (N*)	6.95	Harpoon - Battle Set 3	11.95	Operation Wolf (N*)	6.95	Sword of Honour	17.95
Bunny Bricks	17.95	Harpoon - Battle Set 4	11.95	Oxidant	20.95	Tennis Cup 2	17.95
Cadaver - The Payoff	17.95	Harpoon Editor	13.95	Pacific Islands	20.95	Test Drive II Collection (N*)	17.95
Caesar	20.95	Harpoon v1.2.1	23.95	Paint and Create (Over 5)	17.95	The Manager (1Mb)	20.95
Campaign	23.95	Harties Assault (1Mb)	23.95	Paint Pot 2	13.95	Thomas the Tank Engine	6.95
Capcom Collection	20.95	Head Over Heels	6.95	Pang	6.95	Thunderhawk	20.95
Captain Dynamo	6.95	Head to Head (Comp)	23.95	Panza Kick Boxing	7.95	Tidy the House	10.95
Captive	12.95	Hetudall (1Mb)	23.95	Parasol Stars	17.95	Tip Off	17.95
Casbah	4.95	Hero of the Lance	6.95	Pen Pal	36.95	Thus the Fox	17.95
Carl Lewis Challenge	17.95	Hiroquest - Twin Pack	20.95	Perfect General (1Mb)	23.95	Total Recall	6.95
Casler Command	7.95	Hiroquest 2	17.95	PGA Tour Golf - Courses Disk	11.95	Toughdown	11.95
Cartoon Collection	17.95	Home Account 2	39.95	PGA Tour Golf Plus	20.95	Toyota Celica	6.95
Casino	17.95	Home Alone (1Mb, N*)	17.95	Picture Fractions	10.95	Treasure Island Dizzy (N*)	4.49
Castle Master	6.95	Hook (1Mb)	17.95	Pinball Fantasies (1Mb)	19.95	Treasures of Sav Frontier (1Mb)	21.95
Castle of Dr Brain (1Mb)	23.95	Hoversprunt	6.95	Plan 9 from Outer Space (1Mb)	23.95	Trivial Pursuit	6.95
Castle (1Mb)	20.95	Hunt for Red October	7.95	Police Quest 3 (1Mb)	23.95	Troddlers	17.95
Castle - N Campaign Data Disk	12.95	Improbable Mission 2 (N*)	6.95	Pools of Darkness (1Mb)	23.95	Turron	6.95
Catch Em	10.95	Indiana Jones & Fate All (ACT)	17.95	Populous II (1 Mb)	20.95	Turrican II	21.95
Cave Maze	10.95	Indiana Jones & Fate All (Adv) (1Mb)	25.99	Populous II Plus (1Mb)	23.95	TV Sports Baseball	12.95
Celtic Legends	20.95	Indiana Jones & Last Crusade (ACT)	6.95	Populous III (1Mb)	23.95	TV Sports Boxing	12.95
Centurion	8.95	Indiana Jones & Last Crusade (ADV)	17.95	Postman Pat 3	6.95	Ugh!	17.95
Championship Manager (1Mb)	17.95	International Rugby Challenge	20.95	Power-Up (Comp)	20.95	Ultima 6 (1Mb)	20.95
Chaos Engine (1Mb)	17.95	Isbar - Legend of the Fortrees (N600)	20.95	Powermanger Data Disk (WW)	11.95	Utopia	20.95
Chess Champion 2175	13.95	Italy 1990	6.95	Predecessor	6.95	Utopia - New Worlds Data Disk	11.95
Chessmaster 2100	12.95	Ivanhoe	6.95	Premiere (1Mb)	6.95	Venus the Flytrap	6.95
Chuck Yeager 2	8.95	Jack Nicklaus Golf	6.95	Prince of Persia	20.95	Vikings (1Mb)	17.95
Choo Hea	15.95	Jack Nicklaus Unlimited Golf (Accolade) (1Mb)	20.95	Pro Tennis Tour 1 (N*)	6.95	Virtual Worlds (Comp)	20.95
Civilisation (1Mb)	23.95	Jaquas X220 (1Mb)	17.95	Push-Over (1Mb)	17.95	Viz	7.95
CJ in Space	6.95	James Bond Collection (N*)	17.95	Putty (1Mb)	17.95	Vroom	17.95
Combat Air Patrol	20.95	James Pond	6.95	Quiz	6.95	Wayne Gretsky 2	17.95
Combat Classics	20.95	Jim Power	17.95	Quest For Adventure (Comp) (1Mb)	23.95	Weed - The Prophecy	20.95
Conflict Korea (1Mb)	20.95	Jimmy Whites Whitwind Snooker	20.95	Quest For Glory 1 (1Mb)	26.95	Wild Streets	7.95
Cool Croc Twins	17.95	Joe & Mac - Caveman Ninja (1Mb)	17.95	R.B.I. Baseball 2	20.95	Wily Beast (1Mb)	23.95
Count Duckula	6.95	John Madden's Football	17.95	Race Driver	20.95	Wings Commander I (1Mb)	17.95
Cover Action	23.95	John Madden's Football	17.95	Ragmatak	26.95	Wizards	17.95
Crazy Cars 3	17.95	John Typist (5 - 10)	14.95	Railroad Tycoon (1Mb)	23.95	Wonderland (1Mb)	20.95
Creatures	17.95	Keys of Maramon	17.95	Rainbow Collection	13.95	World Class Leaderboard	7.95
Cruise for A Corpse	18.95	Kick Off - Extra Time	20.95	Rainbow Islands	6.95	World Class Rugby (N600)	17.95
Crystal Kingdom Dizzy	13.95	Kick Off II (1 Meg)	17.95	Rampart	17.95	World Class Rugby - 5 Nations	20.95
Curse of Enchantus (1Mb)	23.95	Kick Off II (Final Whistle) (N*)	9.95	Reading Mad	17.95	World Cup Soccer	7.95
Cyrox	20.95	Kick Off II (Giant of Europe) (N*)	6.95	Reading Writing Course (3-8)	18.95	WWF European Rampage	17.95
D-Generation (1Mb)	12.95	Kick Off II (Return to Europe) (N*)	6.95	Reasoning with Trills	10.95	X-Out	6.95
Dalek Attack	12.95	Kick Off III	17.95	Red Baron	23.95	X-Out	6.95
Daley Thompson's Olympic Challenge	6.95	Kick Off III (Final Whistle) (N*)	9.95	Renegade	6.95	Zak McKracken	10.95
Dark Queen of Krynn (1Mb)	21.95	Kick Off III (Return to Europe) (N*)	6.95	Rick Dangerous 1	6.95	Zool (1Mb)	17.95
Death Knights of Krynn (1Mb)	20.95	Kick Off III (Final Whistle) (N*)	9.95	Rise of the Dragon	26.95	Zool - Enhanced (Amiga 1200)	17.95
Deliverance	17.95	Kind Words 3 (1Mb)	17.95	Road Rasher	17.95	Zyconix	17.95
Deluxe Paint IV	59.95	Knights of the Sky (1Mb)	23.95	Robocod	17.95		
Deuteros (N*)	20.95	Kwik Stax	6.95	Robocop I	6.95		
Discovery in the Steps of Columbus	20.95	Leander	17.95	Robocop II	15.95		
Dizzy Collection	17.95	Leeds United Champions	17.95				

3 1/2" Double Sided Double Density

QUANTITY	PRICE
10	£5.30
20	£10.35
25	£12.65
30	£14.75
35	£16.90
40	£18.95
45	£21.10
50	£22.95
80	£36.35
100	£41.70
120	£49.40
150	£60.95
200	£78.75
250	£97.30
300	£116.30
400	£154.50
500	£184.65
1000	£364.30
2000	£728.50

WITH LABELS & WARRANTY

BOXES

(with keys and dividers)

10 Shmpack	£0.94
40 capacity	£4.95
50 capacity	£5.60
80 capacity	£6.30
80 capacity stackable Banx	£14.95
100 capacity	£6.80
120 capacity	£8.75
140 capacity	£9.95
150 capacity	£10.95
150 Deluxe stackable	£21.95

JOYSTICKS

Python 1 (QS130F)	£9.25
Maverick 1 (QS128F)	£13.75
125+	£9.00
The Bug	£13.50
Star Probe	£13.50
Competition Pro 5000 - black	£13.75
Speedking A/F	£11.00
Navigator A/F	£13.75
Topstar (SV127)	£21.50
Supercharger (SV123)	£9.00
Sting-Ray A/F	£12.50
Megastar A/F (SV133)	£22.00

MISCELLANEOUS

Cartoon Classics Pack	£359.95
Deluxe Work Centre	£46.95
Cumana Disk Drive	£57.95
0-5Mb Upgrade + clock	£29.95
0-5Mb Upgrade	£26.95
1Mb Upgrade (500+)	£56.95
Mouse	£14.75
Mouse Mat	£2.95
Mouse House	£2.95
Dustcover (Amiga 500 or +)	£3.65
Dustcover (Amiga 600)	£3.65
Dustcover (Monitor)	£6.99
Dustcover (LC10)	£7.65
Dustcover (LC24)	£6.99
Auto Mouse/Joystick Switch	£14.75
Trackball	£28.75
Head Cleaner	£3.75

MINI OFFICE £49.95

Word Processor Spreadsheet
Database Graphics Disk Utilities

Philips CM8833II Monitor with Lotus Turbo Challenge II, Dust Cover, Scart Cable, 1 year on site warranty, free next day delivery.....£224.95

All Prices include UK postage and VAT and are effective until 10th January 1993

Overseas orders - Postage charged at cost

New titles will be sent as they are released and are subject to manufacturers price reviews.

Credit Card orders (10.00am - 10.00pm, 7 days hot an answer phone)

Fax orders: 071 608 0618

New extended opening for Christmas from November 7th

Showroom open 10am - 5pm Weekdays, 10am - 4pm Saturdays

071-608-0624

Cheques/Postal Orders to DataGem Ltd, Dept AF, 23 Pitfield Street, London N1 6HB

Showroom open Monday - Friday 10am - 6pm Exit 2,

Chart busters

Bought a chartbusting game? Are you muddled and fuddled? Or are you just stuck and in need of help on the latest releases? If so, then read on...



PINBALL FANTASIES

Type the following cheats in before you select the number of players...

EXTRA BALLS - gives you five balls instead of the usual three.

DIGITAL ILLUSIONS - stops the ball going out of play. You won't be able to enter your name on the high-score table, or collect your bonuses though.

HIGHLANDER - makes your balls heavier.

VACUUM CLEANER - clears high scores.

EARTHQUAKE - disables the tilt function.

FAIR PLAY - sets cheat options to default.



HUMANS

Here are some early level codes to the Lemmings-style puzzler:

- | | |
|----------------|--------------------|
| 1 - Darwin | 2 - Andie Pandie |
| 3 - Get a life | 4 - Carlos |
| 5 - Howie | 6 - Mooble |
| 7 - CSL | 8 - The Humble One |
| 9 - Pixie | 10 - Milestone |



AQUATIC GAMES

Some cheats and tips:

100M SPLASH - run along the top of the water, then jump over the pelican. He will fly off, then come and carry you over half of the course. If you knock all three toucans off, two pelicans will carry you in turn.

In one-player mode, don't start running, just let the penguin kick you until you fall in the water. This will give you a 10,000-point bonus and reset your time.

JUGGLING - rotate joystick madly to juggle all five balls.

SHELL-SHOOTING - go to the right, then jump on the jelly limpet. You will go through the roof, where there is a king limpet, bonuses and limpet mines.

BOUNCY CASTLE - a forward or backward somersault followed by a twist will give you a spring box. Use this to gain greater height. Do a twist at the top of your jump to go through the roof for bonuses.

HOP, SKIP & LONG JUMP - make the final jump and keep waggling while in the air for greater distance. If you get a really long jump, prepare for a surprise...

UNICYCLE - rotate the joystick slowly and steadily instead of manically.

FEEDING TIME - if butterfly hits fish, you will get a 1,000 point bonus. Time throwing sweets to the fish so that you trap butterfly between fish for a bonus.

KIPPER WATCHING - leave the clock and let it ring for a large bonus - watch the seals, though...

Game Busters

Here's an extended GameBusters - a massive six pages filled with hints, tips and solutions to the games which are bringing you to your knees in frustration. **Andy Nuttall** is the man to help...

PUTTY IN YOUR HANDS...

£25 Considering this silly platformer's excessive popularity, (plus it's been bundled with new A600s) hints and tips haven't exactly been forthcoming for Putty. So here in the Amiga Format office we decided to reward the one reader who sent some in with a £25 voucher...

SO YOU WANT SOME HINTS THEN?



Dweezil makes an unusual entrance...

- At the start of the game, go left out of the gym door to finish the level quickly.
- Look for things that stand out of the scenery, because they could contain hidden bonuses.
- Always keep on the move.
- Punch, squash or absorb anything and everything that moves.
- On later levels give the Bots cups of coffee to stop them from moving.
- Always drop long distances - as long as there are no spikes to break your fall!

A ROUGH GUIDE TO FINDING BONUSES...

- Level 1-1 Absorb the spider to get some food. Jump to the putties in the window for a score bonus.
- Level 1-2 Jump around to find watches.
- Level 1-3 Go to the bottom-right of the screen, and jump to receive a score bonus.
- Level 2-1 The tree at the top of the level gives you extra score, and the tree at the bottom gives you Dweezil power.
- Level 2-2 The first tree gives you a score bonus, and the one above it gives you a pair of false teeth if you jump.
- Level 2-3 If you jump on the lowest tree on the right you will receive the all-important bubblegum.
- Level 3-1 Mould into a rabbit to kill the Gut Buckets, and turn into an Electro Worm (?) to kill the light bulbs. Jump at the top for extra power-ups.
- Level 3-2 To get Dweezil power, jump on the picture. Jump near the planet to activate Uncle Ted.
- Level 3-3 Jump at the girl's face and the computer screens in order to get an arrow and an elevator.
- Level 4-1 Jump at the middle door at the bottom to activate Uncle Ted. At the top of the level, jump at the right gong to get an elevator.
- Level 4-2 Jump at the middle door to activate Uncle Ted, and at the dragon symbol for bubble gum. Jump on the door for an elevator.
- Level 4-3 Jump on the symbol on the right for an arrow.
- Level 5-1 There are plenty of bonuses to be found on this level. The best one to get is the dustbin - to obtain this you have to jump on the cannonballs at the top of the level.
- Level 5-2 Some of the igloos have food in them.
- Level 5-3 Some of the doors have food in them.
- Level 6-1 Jump around to get arrows.
- Level 6-2 There are bonuses in the pictures.
- Level 6-3 Jump near the tower for a surprise.

Paul Wills Taylor
Horncastle

Shadow of the Beast 3



The Beast series has been consistently good looking, but in the past the games have been very annoying when you die, and Beast 3 continues that tradition. So what better than some tips from the programmers to ease your frustration...

AMIGA FORMAT

LEVEL ONE: FOREST OF ZEAKROS



Run right, shoot the circular plants in the trees while avoiding the purple blobs that are fired at you. Jump on the elevator, then flip the switch once. Wait for the lift to reach the top, then run right, collect the gold, and shoot the goblins that are running towards you. Continue right, level out the two platforms by shooting the first wheel a couple of times, then collect the grenade.



Shoot the cog three or four times to level out the two platforms - then watch out for the lasers...

Change to the grenade from your inventory by pressing F1, then shoot the lasers on the moving platforms. Collect the key from the fourth platform, then go back to the first. Wait for it to go down, then use the key on the door and collect the gold. Go back up on to the platforms, then run right towards the village.

Shoot the goblins, then go down the ladder and run right while shooting the other goblins. Shoot at the meat which is cooking on the fire, and push it just under the spikes. Collect the key, then go back and use it on the monster's cage. Jump on the ladder, then follow the monster until it gets killed by the spikes. Collect the gold, then jump on to the jet platform.



End-of-level guardians don't come much bigger than this - remember to keep jumping, and shoot a lot...

Move the platform to the left, then level it out so that the rock is carried with you on the way up.

Carry on until you get to the top, then push the rock to the left until it falls over the edge. Jump to the left so that you land on the platform, then run up to the metallic spiky things on the left. Wait until the first spikes disappear, then run through them. Do the same thing for the second set of spikes. Fall down the broken cliff, then repeatedly jump and shoot at the guardian until he dies. Collect the skull.

LEVEL TWO: FORT DOURMOOR



Go right and hit the switch, then run left with the wheel. Fix the battering ram, and run right with it. Destroy the door, run over the bridge, and duck down. Destroy the platform that the balls are bouncing off, then run right and kill all the wasps before collecting the gold. Go left to fall down the hole, and shoot the gold lock on the right.



When you float to the top, this lever opens both the gates at the bottom, so you float down again.

Go right and fall down the tunnel, then move the table left until it's just underneath the porthole by the door. Jump on to the table, kneel down, and shoot the lever on the left. The table will move upwards. Shoot the lever on the right, then wait until you go back down. Go right, collect the gold and go up the ladder. Push the table into the water and kill the monster.

Jump right over the gap, then push the box to the left until it falls. Jump left over the gap, then walk right until you fall. You will now find yourself standing on the box, so walk off to the left and quickly push right so that you fall on to the table. Shoot the box until it explodes into splinters, then go right until you see a barrel. Now you must quickly jump over the hole, shoot the monster, then jump back over the hole again. Do this repeatedly until you kill the monster, but remember to keep on the move, or the crane will get

you. Now go back and push the barrel to the very end of the floor, near the hole.

Go down the ladder, then close the left shutter (but don't kill the green monster yet). Go to the top of the ladder, then go left. Jump over the swinging mace, then collect the gold. Go right, and kill the beheaded monster by shooting his neck.



You don't need to kill the headless monster in order to complete the level - but it's incredibly satisfying...

Go down to the place where you killed the man, and fiddle around with the lift controls. Pick up the barrel and put it near the ladder on the conveyor belt.

Get in the barrel, but don't close the lid. Shoot the belt switch, then close the lid. Fall down the hole, and a monster should drag you along and drop you in some water. Jump on the land when you reach it, and go left.

LEVEL THREE: CAVES OF BIDHUR



Run right until you are past the two creatures on the bridge, then jump up and shoot them from behind. Continue right and jump on to the first branch. Stand as far right as possible, face left, then jump up the branches and shoot the nest and four birds at the top. Run right and jump off the edge.

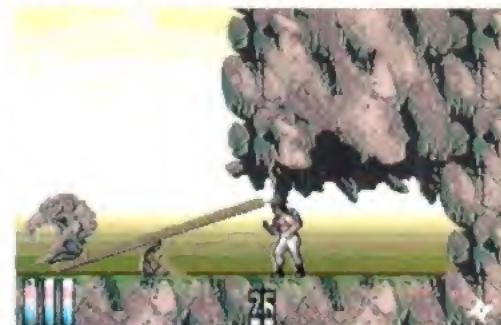

You will have to try to catapult this ugly-looking figure so that it hits the bird cage.

Keep going until you see a table, then shoot the left leg. Jump to the other side of the table, and shoot the right leg. This leaves a pivoted plank. Shoot the head in the rocks from behind, so that it falls on to the left of the plank. Push it as far as possible to the left, then climb the ladder and run off the ledge to the right. You will catapult the head up so that it hits the bird cage.

Stand in front of the bird, and press fire. Once you are on the bird, stand diagonally up and right until you see a column of metal balls. You will also notice a set of adjustable runners. Adjust them so that they will direct the balls into the top cave, then release the first three balls by shooting the switch at the top. Now adjust the runners so that they lead to the next cave down, then release the remaining balls. Fly down to the shaft below until one of them drops a hammer – pick that up then fly back up to the top cave.

Dismount the bird, then go right through the gap – dodge left when the slab falls. Change your weapon to the hammer, then push a metal ball to the edge of the



This section's possibly the most difficult part of the game – prepare for much frustration shooting birds...

shallow pit. Shoot the slab a few times to move it on to the metal ball, then keep moving the balls from the back of the slab to the front – keeping the slab moving. Once the block reaches the right of the shallow pit, keep throwing the hammers until it won't move.

Change your weapon back to the throwing stars, then use the slab as a step to reach the higher platform. Go right and kill the monster by shooting it repeatedly in the eye. When it's dead, go right and collect the empty glass flask from the lab. Go back to the bird, get on it, then fly to the next cave below the one you've just been in. Fly past the bouncing balls to the edge of the red lake, dismount, then select the flask as the current object. Jump into the middle of the red lake, then press fire to fill the flask.

LEVEL FOUR: NOSTHOMAK

Run right, and duck the flames while shooting the flame-thrower. After it's destroyed, continue past the steel ball then go downstairs. Shoot the left leg off the table, then push it as far right as it will go – don't fall off the ledge yourself. Shoot the bats to reduce the harm that they do to you. Push the bookcase left until it's just before the library sign, then climb the ladder and jump on top of the bookcase. Jump and collect the hammer.

Climb up the ladder, and go back up the stairs to the large steel ball. Shoot the ball twice with your throwing stars, then switch to the hammer and start rapidly shooting at the ball until it's at full swing. Jump on to the ball as it's coming towards you, and let it carry you up to the high platform on the right. Jump off the ball, then switch back to your throwing stars and shoot the ball when it's at the highest point of swing. The ball should now detach itself from the chain and roll down the stairs.

Continue right, past the sliding puzzle – it's not necessary to complete the puzzle – then go down the



Keep shooting the metal ball until it's at full swing, then jump on it and leap to the platform above.

ladder into the crane booth. Pick up the fish at the bottom of the top-left tank, and feed it to the top fish in tank three. Pick up the latter when it has eaten the small fish, then feed it to the fish in tank one. Take the fish from tank three, and feed it to the small shark in tank two. The small shark is the only fish that will not harm you. Move to the exit box and press fire.

Climb the ladder, then run through the tanks. Go down the ladder after tank three, and fall down the drop to the right. Jump over the ball, then climb down the ladder. Run right, jump the small pit, jump on the ledge, then shoot the switch to turn the furnace on. Stand next to the furnace, select the hammers and keep



Catch the fish in the right order – but be careful, choose the wrong one and you'll be back at the beginning.

shooting the furnace until it won't move any further. You will see some spikes hanging from the ceiling from a chain slightly to the right. Switch your weapon to the throwing stars, then jump up and shoot the spikes twice and a small crack appears in the chain.

Switch your weapons to hammers, then repeatedly jump up and shoot the spikes until they are at full swing. Quickly change back to the throwing stars, and shoot the spikes when they're at the highest point of their swing to the left. The spikes will then detach from the chain and plug the shallow pit on the floor.

Go left, and climb the ladder. Jump over the large ball, and push it to the right until it falls into the furnace. Run right, and jump on the small platform next to the furnace switch. Wait for the ice to start melting, then when the top is just below your platform jump on to it and then immediately to the ledge on the right. Hit the switch on the wall which will turn off the force field below you. Wait for the molten metal on the floor to cool, then drop down from the platform. Collect the crystal on the floor, and walk right until you're directly beneath the other crystal which is embedded in the ice. Keep shooting the ice with the throwing stars until it shatters, and you will then catch the second crystal.

THE FINAL CONFRONTATION: DEFEATING MALETOH

Run and jump on to the platforms, then repeatedly fire at Malethoth's head. Change platforms every time he goes past you, and try to destroy him ASAP.

OH NO!

IT'S THE PATHETIC TIPS!

Every month we receive hundreds of letters from readers offering tips for various games. Although most of them are fine, some are not-so-hot. This month we begin a series containing some of the more bizarre entries...

The honour of being the first among equals goes to Michael Confor of King's Lynn, who writes: 'If you know you're going to die – for example, when the beast grabs you with the claw – quickly tap the Help key, and you will restart at the last load.' That's great Michael – but I'm afraid that you forgot to write which game this tip applies to!

On a similar planet to Michael is Jonny Reed from Dartford, who wrote in with the following: 'In *Monkey Island 2*, hold down both Amiga keys and both Alt keys, and you will be prompted with the message 'do you want to win?'. Press 'Y', and you will be instantly transported to the end sequence.' Guess what? It doesn't work. At all. Ever.



Here's a tip on *Monkey Island 2* that's about as useful as a condom on a stud farm.

Dave Paget of Radstock came up with this gem for *Kick Off 2*: 'If you hold down the 'D' key when the team who didn't kick off have the ball, a trail of players will be left on the scanner until you let go of the key.' Superb! Thanks, Dave.

Simon Ambrose of Warwickshire goes one better with a 'cheat' for *Sensible Soccer*... 'To have a chance at beating the top teams,



If you find that Beckenbauer is a bit too good a player for you to handle, put him in goal...

first choose one for yourself, then go to 'Edit Teams' and choose your opposing three teams. Swap the opponents players around so that the star players are on the bench, put the 'keeper in at centre forward and put an out-field player in goal.'

Excellent! If you can't beat your opponents fairly and squarely, totally obliterate them first and they'll be easy pickings! That sounds like just the sort of battleplan that Saddam Hussein would use...

Thanks for those – they're completely useless... more next month.

VEKTOR STORM

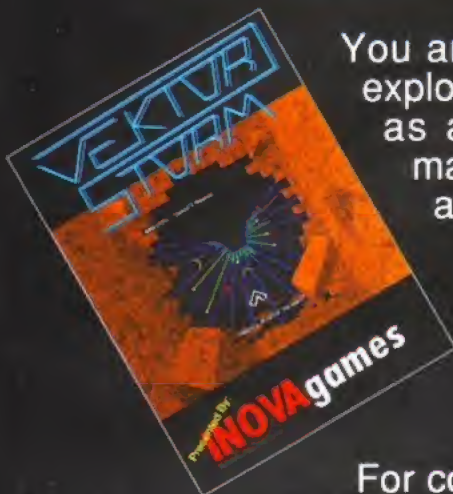

You are the Commander of a small reconnaissance fleet sent to explore an anomaly in the space-time continuum, otherwise known as a "Black Hole". By way of an unexplained equipment malfunction, your fleet exits hyperspace too close to the vortex and is drawn into the void.

When you emerge from the worm hole, you find yourself in a universe fragmented from your own since the big-bang. Everything you knew as truth is now false. Even the very laws of physics have changed.

For countless eons, a sole entity has occupied this universe alone, waiting....

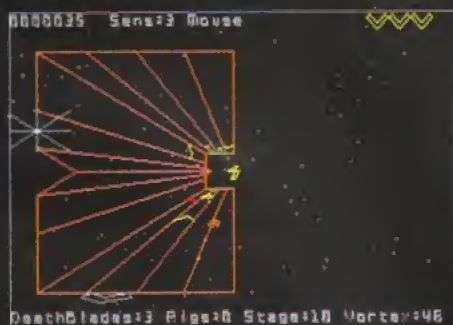

To return to your universe, you must first meet the challenge set before you by your captor: *Beat him at his own game.* Your four remaining ships must fight against an arsenal of intelligent weapons on a series of battlegrids.

The rules are simple. The stakes, ***Your very existence!***

Experience graphics, animation and stereophonic sound like you've never felt before... Pick up a copy of **Vektor Storm** today, and prepare yourself for the fight of your life!



Minimum System Requirements:
512K RAM With Kickstart Version 1.3 or Higher.



NOVAGAMES

Plan 9 From Outer Space

Are you stuck in a world of B-Movies, hub-caps and magic Styrofoam? Know what we're talking about? Then you're playing Plan 9! GameBusters is here to move you on to Plan 10...

£25 Before you start, remember – if you want to watch any of the reels of film found in the game, then you can either watch them in the editing room of Cheapflik Studios or any of the project booths you will come across.



Fat American film producers aren't really known for their mastery of the English language...

At the start of the game, you'll find yourself in the producer's office. Go in the hall, then down to the foyer. Walk into the street, past Joe's Diner and into the Hub-Cap Bar. Talk to the woman (if it is a woman) by the bar. She will mention Vlad the Impaler St, which is where Bela Lugosi used to live.

Talk to the barman, and buy the bottle of rum from him. Go back to the producer's office, and see if he has gone. If he hasn't, then keep going in and out of the

studios for a while until he does. If you examine his desk, you will find a key for the editing room. Go in his private room on the right, and examine the pictures on the wall – in particular the one on the left. This will give you an address – Lot 9, Pleasant Rest, Highgate.

Go downstairs and ask the doorman to call a cab. Tell the cabbie to take you to Lot 9, Pleasant Rest, Highgate. When you arrive at the cemetery, go through



Examining the top left-hand picture on the wall will give you an address to visit, then let the taxi take the strain.

the gate and enter the crypt. Examine Bela's body to discover a door key, then pick up the hammer. Get back in the cab, and go to Vlad the Impaler Street. Enter the house, then go left into the study.

Examining the flyer on the table next to the books will reveal an advert for the local shopping mall. Pick



Examining the stag's head, though, reveals a credit card. Funny, that – I usually keep mine in my wallet...

up the pictures of Bela from the table, then examine the trophies on the rear wall. Push the one on the left, and a credit card will fall out. Leave the house and take the cab to the Hypermega Mall. Press the lift call button, then go inside when the doors have opened. Press button two, then enter the Lycanthropository.

Talk to the woman, use the credit (TrEx) card to buy the scary mask, then examine the mask and you'll find a note with a key. Read the note, then go to the fifth floor and enter the Hardware Store. Say to the assistant: "Nice day for gatherin' corn," then examine the spade and buy it (using the credit card). Get a copy of your passport photo by using the passport with the photocopier. Go to the sixth floor, and enter the Bank.

UGH! – ENOUGH! IS ENOUGH!

Well as great three-letter, Neanderthal game names go you can't go wrong with Ugh! And as a cute little platform game you can't go far wrong either, though some people do go badly wrong, but that's why we're here with the level codes...

Level	Code	Level	Code	Level	Code	Level	Code
2	SELBSTLAUFER	19	PICASSOONBICYCLE	36	FISHYREQUISITTE	53	THESENSIBLEPARTY
3	HENNABREGGL	20	SPANISHINQUISITION	37	ARTHURFIGGIS	54	ADOPTADAPTNIMPROVE
4	PFANNEHEISS	21	LUIGIVERCOTTI	38	CRUNCHYFROG	55	HELLOSAILOR
5	SOICHGOMBASEPP	22	JIMMYBUSSARD	39	SPRINGSURPRISE	56	ARTHURTREE
6	2PFUNDHACKFLEISCH	23	KENCLEANAIRSYSTEM	40	WALLYWIGGIN	57	ABLOCKOFWOOD
7	DOGODDERDEIG	24	JOHANNGAMBOLPUTTY	41	SIXTEENTONWEIGHT	58	LIONTAMING
8	SPAMSPAMBEANSNSPAM	25	TRAINSPOTTING	42	RASPERRYKILLER	59	RONOBVIOUS
9	SEMPRINI	26	BICYCLEREPAIRMAN	43	SCOTTOFTHESAHARA	60	CHANNELJUMP
10	PROFRJGUMBY	27	IRVINGCSALTZBERG	44	BISHOPOFEASTANGLIA	61	TUNNELINGTOJAVA
11	CONFESS	28	THEENDBERG	45	POLLYTHEEXPARROT	62	MAURICEZATAPATIQUE
12	MITTERMEIER	29	HOWTOFLINGANOTTER	46	EWANMCTEAGLE	63	KENBIGGLES
13	DIESCHNICKIANGST	30	THECATSATONTHEMAT	47	ASCOTSMANONAHORSE	64	ALIBAYAN
14	INTERESTINGPEOPLE	31	CONFUSEACATLTD	48	KEITHMANIAC	65	KENDOVE
15	INSURRANCESKETCH	32	DISTRACTABEE	49	NOTGOODENOUGH	66	TIDDLES
16	ITSTHEARTS	33	MITTELSCHMERTZ	50	STILLNOTGOODENOUGH	67	THENAKEDANT
17	ARTHURTWOSHEDS	34	INSPECTORTIGER	51	NUDGENUDGE	68	KENSHABBY
18	HAROLDTHESHEEP	35	LOOKOUTOFTHEYARD	52	THEWOODPARTY	69	ALBATROSS



Use the blurred photocopy in the pilot ID so that you can board the plane. Oh, and learn how to fly...

Talk to the teller, then change some of your money into the currencies of Washington, Brazil, Hong Kong and Australia. Examine the credit card and note the number on the back (350143). Hand the key you found in the mask to the teller and she'll ask you for your deposit box number. Look at the range of numbers she offers, and pick the one closest to yours (530143).

Open the box and take the reel of film (hooray!). Examine it, and you'll see that it has the word 'Wun' written on it. Next go to the Travel Agents on level three and buy a ticket to Rio (using the credit card).

Leave the mall and go to the cemetery. Enter the gates, then go left where you will find a grave with a wooden cross. Use the spade on the grave three times to dig it up, then you should come across the second reel of film. The reel should be marked 'Of'.

Go to the airport, and give the ticket to the airline rep. Board the plane, then go inside the cockpit and talk to the pilot. Ask if he knows a place to stay, and



The dull, lifeless vault contains a dull, lifeless film canister - coincidentally containing a dull, lifeless film...

note his name - he will tell you about something he left behind in Rio on his previous visit.

When you arrive in Rio get in the cab, and you will be taken to a hotel. Examine the book on the counter, and note the room number which the pilot

stayed in. Ask for the same room, then go upstairs. Take the Pilot ID which is on the table, examine it for the Pilot's address - 21 Aviation Way, Studio Town. Replace his photo with yours. Now leave and go to the cave on the beach. The bats will take the picture of Bela from you and leave you alone. Pick up the third reel of film, which will be marked 'Lo'.

Go to the airport, where a group of security guards will arrest you and take you to the police station (note: it's a waste of time bribing the guards.) After your trial you will find yourself in a cell. Give the bottle of rum



What a scatterbrain that pilot is, leaving his ID behind in Rio. That's just asking for trouble...

to the guard, and he will leave - dropping a statuette on the way. Pick it up, and use the hammer on it. Inside you will find a slimy Deathhead Moth pupa (what kind of storyline is this, anyway?). Go to the airport, and give the Pilot ID to the rep. Fly home, then get a cab over to Aviation Way.

Use the credit card to open the door, then drop the spade, small key, room key and house key. Pick up the scuba gear, then go into the back garden where you'll find the fourth reel of film, marked 'Property'. Go to the store room of the studio, then pick up the love beads. Take a cab to the airport, then give the Pilot ID to the rep, select Australia as your destination, then board the plane.

Go to the beach, and talk to the sexy (?) bather - say 'Hi there! Nice weather'. Then ask her if she would like the love beads. She will take them, and lead you to a hippy commune. Fly home, and go to the building site outside Cheapflik Studios. Talk to the two blokes about the hippy commune, then go to the diner and pick up the balloon. Go back to the store room in the studio, then drop the mask and the note. Pick up the dictionary, then fly back to Australia and go to the hippy commune again.

Talk to the hippies about Fred, and they will give you a reel of film marked 'H.K.'. Go to the bridge on the left of the Sydney Opera House and talk to the painter. You will slip and fall in the water - quickly use the scuba gear before you drown. Pick up the



The nice house in Aviation way contains some scuba gear - you can't get up the stairs though, unfortunately.

crowbar, then use the balloon with the scuba gear. You will now shoot to the surface.

Fly to Hong Kong, and talk to the movie mogul. He'll tell you about the Netsuke which was stolen. Fly to Washington and talk to the chief, who'll send you to Cuba. While you're standing on the wharf, the guard will speak to you. To understand what he is saying, examine the dictionary. He will give cigars and a poster, so go back to Washington and give them to the chief. He will send you to the Smithsonian Institute.

Get in the taxi and when you arrive at the Institute give the slimy pupa to the curator. Go to the warehouse and examine the crates until you find one marked 'O.R. Yental, Hong Kong'. Use the crowbar to open it, it will reveal the Netsuke and the last reel of film. Fly back to Hong Kong and give the Netsuke to the movie mogul who will give you an ancient talisman. Go to the border, then go across the wall to China.



Talk to the painter too much, and you'll fall into the sea - fortunately, you have waterproof pockets...

A group of Ninjas will jump out and take you to a monastery. Quickly give the talisman to the monks, who will take you to see the Aliens... Game over, man... Game over.

**Matt Taylor
Balcombe**

SIM CITY - LAND OF FAKES AND MONEY

Although Sim City has been tipped pretty extensively in the past, we still manage to acquire new tips on this simulation for wannabe town planners everywhere. So if you're a fan here's how to avoid natural disaster...

Most people know that by simply typing the word 'FUND' (in capitals) it will give you an extra \$10,000. This can then be used as many times as you like, but the problem is that after every five times you will suffer an earthquake. So how do you avoid the earth tremors?

A good trick is to build up a huge fortune by typing 'FUND' loads and loads of times on bare terrain - that is, before you start to build your city. That way the earthquakes will do no damage, because there is nothing to be damaged. When

you have enough cash you can start building. If you need some cash while playing, first off put the game on pause, then type 'FUND' repeatedly until you have enough money. Unpause the game and you will only suffer one earthquake - regardless of how many 'FUND's you've typed. If you save the game before restarting it, and then reload, you may be lucky enough to miss the earthquake altogether!

**Maureen Ann Baker
Rothsay**



Gothan City à la Sim City. It hasn't 'arf changed since Batman moved on to the Big Screen...

Amiga 600



- The compact Amiga
- 1MB of RAM
- Built-in TV modulator
- IDE Hard disk controller built-in
- PCMCIA Card slot
- Includes Power Mouse Mat
- Includes Apache joystick

Amiga 600	£285
Amiga 600 & 40MB HD	£455
Amiga 600 & 60MB HD	£499
Amiga 600 & 80MB HD	£549

Amiga 1200



- 32-bit computer
- 68020 microprocessor
- Optional 68881/68882 floating point unit
- 2MB RAM
- PCMCIA Card slot
- 16.8 million colour palette
- Displays up to 256,000 colours on screen
- Includes Power Mouse Mat
- Includes Apache joystick

Amiga 1200	£390
Amiga 1200 & 40MB HD	£560
Amiga 1200 & 60MB HD	£604
Amiga 1200 & 80MB HD	£654

Internal Hard Drive

40MB Internal hard disk	£199
80MB Internal hard disk	£269

Blizzard Turbo

- A500/A500+
- Expand up to 8MB (0K installed)
- Memory and 68000 CPU run at 14.28MHz
- Fast 68000 processor installed on-board
- Fully auto-configuring
- Optical 512K shadow RAM on extra memory bank for shadowing the operating system out of ROM or from disk

Blizzard Turbo	£129
Blizzard Turbo 2MB RAM	£185
B'Turbo 2MB RAM + 256K Shadow RAM	£199

Amiga 4000

- 32-bit computer
- 68040 microprocessor
- 25MHz clock speed
- 2MB 32-bit chip RAM
- Built-in 3.5" high density disk drive
- 16.8 million colour palette
- Display up to 256,000 colours on screen
- High resolution graphics
- AGA Custom chip set
- VGA or multiscan monitors
- AmigaDOS 3.0 & CrossDOS

Amiga 4000 & 120MB HD	£2329
-----------------------------	-------

A3000

- 68030 microprocessor with coprocessor
- 2MB RAM
- Hi-Res graphics with 1MB graphic RAM
- Built in SCSI interface
- Hard disk as standard
- 'T' is Tower version

Amiga 3000 & 52MB HD	£1439
Amiga 3000 & 105MB HD	£1569
Amiga 3000T 100MB HD 5MB RAM	£2349
Amiga 3000T 200MB HD 5MB RAM	£2936

PCMCIA Memory



- Ultra slim memory cards
- 1MB & 2MB
- For A600/A1200

1MB Memory card	£POA
2MB Memory card	£POA

Amiga Accessories

A2300 Genlock	£57
A2065 Ethernet Card	£245
A2232 Serial Card	£104
A2320 Display Enhancer	£163

Commodore 1960

- Multisync monitor
- For use with Flicker Fixers
- Very high quality

Commodore Trisync monitor	£479
---------------------------------	------

Educational discounts available

POWER

Power Computing Ltd
Unit 8 Railton Road
Woburn Road Ind. Estate
Kempston Bedford
MK42 7PN



Tel 0234 843388 Fax 0234 840234
Technical 0234 841882

48Hr delivery £2.50 24Hr delivery £4.50
Parcel post delivery £1 (U.K mainland only)

Specifications & prices are subject to change without notice
All trademarks acknowledged, VAT included

Home Music Kit



- The complete music kit for the Amiga

Digital Studio III

- Transform your Amiga into a digital sound studio
- Create your own music
- Re-mix songs
- Piece together various songs

Real Time Sound II

- Add special effects to music
- Over 32 special effects
- Echo effect
- Can work with MIDI instruments
- Each effect can be modified
- Make your voice sound robotic
- Allow your music to sound like it's being played in a concert hall

Stereo Sound Digitiser

- Convert your desired sounds into digital signals

Other Features

- Maximum sampling rate 900 KHz
- Dynamic filtering
- Anti-aliasing filter
- Stereo gain control by software
- Microphone volume scale

Home Music Kit	£49.95
----------------------	--------



Helping Hand

Hooray! The Hand of Helping is here once more to help gamers who are in need and distress. If you've broken down in a game, or if you've just broken down then you need the help of a very nice man. Sorry though, all we've got is **Andy Nuttall**...

AMIGA FORMAT

124

FEBRUARY 1993

RETURN OF EOTB2



Try as I might, I can't get into the big room in the north of Catacomb level three of Eye of the Beholder 2. I keep getting slaughtered by the legion of skeletons. Please restore my sanity and let me know how to defeat them. A cheat for infinite health would be helpful as well.

**Russ Welsh
Hartlepool**

Get that Remove Paralysis spell going, or you'll be Mantis soup.

Aha, bugged by the skellies, eh? First, you have to remember that the skeletons are continually being generated. Just outside the room containing the skeletons, you will find a small room with a lockable door. You must rush into the skeleton room, kill three or four skellies, then run back outside, go into the small room, lock the door and rest. Repeat this until they are all dead, then quickly collect everything from the room - especially the Darkmoon key hiding in an alcove. Then get out of there as quickly as possible.

A program to enable you to cheat the game was included on our Coverdisk Issue 38. This is still available from our Back Issues section (see the Contents Page), and it will enable you to adjust all aspects of your party, not just health.

I have got to the end of the game in EOTB2, and killed Dran Draggore, but then I am immediately wiped out by the dragon. Is there any particular item I need to kill it, or is my party just too weak to handle him?

**Stephen Morris
Haslington**

The dragon at the end is in fact Dran himself, but in a different form. To kill the dragon you must use the +4 Talon sword, which is the only effective weapon in this case. Hit him with it as many times as you can, but when you see him breath in - dodge out of the way quickly (if you value your eyebrows). If you have a numeric keypad, use it to move around - this will enable you to dodge more quickly.

Cheat in Little Puff

Way back in issue 39, Heather, Oliver and Charlotte Day wrote in with a query about the game Little Puff. We've had a few solutions sent in, but they are a bit too long to print in full, so we were pleased when Christopher Hilbert and Richard Martin sent in a cheat.

Simply type in 'FAT DRAGON NINJA', then press Caps Lock and L to skip levels. Unfortunately we couldn't test this out, but try it and see. Thanks lads.

Call of Eldritch

Did any of you out there buy Hound of Shadow, the HP Lovecraft-based adventure? I



Killing the mini-jouster is easy, but the level one guardian? Some find it more difficult...

have come unstuck with it, and would appreciate any help or advice from fellow investigators out there.

**Guy Cole
London**

No, I'm afraid I can't help you out. But I'm sure somebody somewhere knows the solution so write in and help out our Guy.

British bulldogs

In the game Premiere, how do I go about killing the Bulldog in the sub-game at the end of level one?

**Robert Booth
Colchester**

The answer is to shoot him before he can shoot you! It's a quick-draw situation, so when you see him go for his gun, hit the fire-button as quickly as possible. You will need to do this three times to defeat him.

Strike a light

How can I get hold of your marvellous ScreenPlay book, containing the clues to help me in Dungeon Master. I need to know so that I can finish the game and go on to Chaos Strikes Back.

**Maureen
The Twilight Zone**

The ScreenPlay books are available from our usual mail order address in Somerset, which is printed on the Contents Pages of the magazine. The Dungeon Master hints in ScreenPlay One are particularly good.

Pirates ahoy!

On a more serious note, we have had several requests for help with the adventure game

Hook, which involve the number of available mugs in the Crossed Swords pub. Various readers have phoned or written in with this particular poser.

These people have complained that there is only one mug in the pub. This means they are using an illegal copy of the game. Funny one that, pirates playing a game about pirates.

Equally hooked

And now to someone who has a legal copy of the game, and a decent query to boot...

Please can you help me? I've tried following the instructions for solving Hook as set out in the November Amiga Format. I managed to collect the anchor, washing pole, rope, three mugs, a pirate hat AND knock at Mrs Smeedle's door. In fact everything went well until I tried to use the pole to take the pirate jacket from Mrs Smeedle's washing line. She keeps stopping me pinching it!

**J Weaver
Upminster**



Although we printed the solution a few months ago, getting the uniform is still difficult...

Yes, I found this a little bit problematic as well. What you need to do is knock on Mrs Smeedle's door, then rush round as quickly as possible to the washing line and use the pole on the pirate jacket. If this doesn't work the first time around, keep trying - it will work eventually, believe me.

THAT'S ALL FOLKS.

Remember - keep the hints, tips and queries flooding in. We do read all your letters, but only the most interesting or more unusual make it on to the page. No stamped addressed envelopes, please, and no Action Replay cheats. See ya next month.

If you're stuck on a particular game or have a solution to a letter printed in the magazine, then write it down and send it in to us at **HELPING HAND Amiga Format, 30 Monmouth Street, Bath BA1 2BW.**

THE • GAMES • STORE



look out for our fantastic sale offers

stockists of gamegear, megadrive & master system hardware, software, peripherals & boardgames.

special offers in each store weekly

BRISTOL • BIRMINGHAM • BLACKPOOL • CARLISLE • GLOUCESTER • HANLEY
LEEDS • MANCHESTER • MIDDLESBROUGH • NEWCASTLE • NOTTINGHAM
PRESTON • REDDITCH • SOLIHULL • SUNDERLAND • WOLVERHAMPTON

10%
introductory discount
on all repairs received by
31st Dec. '92

**"FIRST TIME"
AMIGA REPAIRS**
and your PC's nationwide
(also printers, monitors etc.)

**INTENSIVE
CARE**
FOR YOUR WORST
NIGHTMARE!

CALL

**0733
391633**

Burford Computer Services

Unit 7, Ailric Square, Woodston,
Peterborough PE2 7JP



Simple, No-Gimmicks
Repair Price
including Parts, Labour
and Return Delivery

£44.95

*Repair including replacement keyboard or disk drive £14.94

Full 90 day guarantee on all repairs. Qualified and experienced engineers.
Associated services

OTHER MANUFACTURER'S REPAIRS, UPGRADES and TRAINING.

Price Busters!!

Graphics & General

AmigaVision.....	44.99
AntiA.....	24.99
Art Department Pro 2.....	129.99
Big Alternative Scroller.....	34.99
Big Alternative Scroller 2.....	54.99
Broadcast Titler 2.....	149.99
Deluxe Paint 4.1.....	54.99
Charts & Graphs.....	59.99
Expert Draw.....	49.99
Expert 4D Jr.....	39.99
Font Grabber.....	19.99
Gallery - NEW!.....	39.99
Gold Disk Office 2.....	79.99
Hotlinks.....	49.99
Imagine 2.0.....	169.99
Maxiplan 4.0.....	39.99
Morph Plus - NEW!.....	129.99
Personal Finance Manager Plus.....	19.99
Personal Font Maker.....	29.99
Presentation Master.....	149.99
Professional Calc.....	99.99
Pro Draw 3.0.....	89.99
Real 3D Beginners.....	99.99
Real Things - Dogs.....	19.99
Scala 500.....	64.99
Take 2.....	34.99
Video Director.....	99.99
Vidi Amiga 12.....	84.99
Vista Pro 2.....	49.99
XCAD 2000.....	89.99
XCAD 3000.....	279.99

Educational

Compendium 6.....	24.99
Distant Suns 4.1.....	39.99
Fun School 4 Series.....	15.99
GB Route Plus.....	29.99
Micro Series.....	16.99
Tekno Amiga.....	59.99

Development & Utilities

AMOS.....	29.99
AMOS 3D.....	22.99
AMOS Compiler.....	19.99
Easy AMOS.....	22.99
Amos Professional.....	44.99
Cross DOS Plus 5.0.....	24.99
Blitz Basic.....	39.99
Can Do V1.6.....	64.99
Can Do V2 - NEW!.....	99.99
Dev Pac 3.0.....	49.99
Directory Opus.....	25.99

Hi Speed Pascal.....	64.99
Home Accounts 2.....	36.99
Quarterback 5.0.....	39.99
SAS C V6.....	199.99
Turbo Print Pro 2.0.....	39.99

Hardware

Data Switch.....	19.99
Kick Back with 1.3 ROM.....	39.99
Colourburst.....	249.99
1.5Mb RAM with Clock.....	82.99
Invision Plus/Live.....	399.99
Flicker Fixer 2 A500.....	199.99
Naksha Mouse.....	22.99
Optical Mouse.....	29.99
Rendale 8802 inc Ext Cable.....	149.99
RocGen Genlock.....	84.99
RocGen Plus.....	129.99
RocLite Drive.....	54.99
RockKey.....	249.99
Podscat Graphics Tablet.....	179.99
Star LC200 Colour Printer.....	169.99
Star LC24-200 Mono Printer.....	189.99
Touch Screen for Amiga.....	229.99
3 Button Track Ball.....	34.99
Zydec Trackball.....	29.99
Zydec Amiga Drive.....	49.99
Zydec A500 1Mb RAM Card.....	44.99
Zydec A600 1Mb RAM Card.....	44.99
Sharp JX100 Mono Scanner.....	349.99
Sharp JX730 Colour Printer.....	899.99

Music & Sound

AD1012/Studio 16 Card.....	399.99
Aegis Sound Master.....	89.99
Audio Engineer Plus 2.....	149.99
Music X 1.1.....	49.99
Pro Midi Interface.....	19.99
Stereo Master.....	29.99
Techno Sound Turbo.....	29.99

DTP & Wordprocessing

Excellence 3.0.....	39.99
Final Copy 2 - NEW!.....	64.99
Kindwords 3.0.....	34.99
Mini Office.....	39.99
Page Setter 2.....	34.99
Page Stream 2.2.....	129.99
Pen Pal.....	34.99
The Publisher - NEW!.....	39.99
Protex V5.5.....	99.99
Transwrite.....	29.99
Wordworth 2.0 - NEW!.....	79.99
Works Platinum.....	34.99

Post & Packing £1.50 - Securicor £5.00
48 hour despatch - Cheques 7 days
Access and Visa accepted
(Cheques should be made payable
to Softstore)

**SOFTSTORE, PO Box 1720,
Slough SL3 0YX**

0753 683336

Orders Taken Until

DISKS...DISKS

Phone for latest prices
 FULLY GUARANTEED BULK DOUBLE SIDED DOUBLE DENSITY 135rpm 100% Certified - UNBRANDED USUALLY SONY, TDK or MITSUBISHI etc GUARANTEED AND SUPPLIED WITH LABELS DO NOT CONFUSE WITH INFERIOR UNCERTIFIED. PLEASE PHONE FOR LATEST PRICES.

20 DSDD	£9.99	25 DSDD	£12.99
50 DSDD	£22.99	100 DSDD	£42.00
200 DSDD			£82.00
20 TDK Branded Disks with two 10 holder boxes			£19.99

DISK BOXES

Flip Top Disk Holder holds 12	99p
Flip Top Disk Holder holds 20	£2.99
40 Disk Holder, Lockable, Top Quality, Anti-static, with Dividers & 2 Keys	£3.99
80 Disk Holder, Lockable, Top Quality, Anti-static, with Divider & 2 Keys	£5.99
100 Disk Holder, Lockable, Top Quality, Anti-static, with Dividers & 2 Keys	£6.99

DISKS & DISK BOX OFFERS

Pack of 20 in our Top Quality, Lockable 40 Disk Holder	£13.99
Pack of 50 in our Top Quality, Lockable 80 Disk Holder	£28.99

FILE DRAWER

Drawer Type Box - Holds 200 disks, lockable, stackable	£12.99
--	--------

POSSO BOX

Drawer Type Box - Can be stacked horizontally or vertically - Holds 150 Disks	£16.45
---	--------

DISK LABELS

Four Assorted Colours	
60 for	£1.00
200 for	£2.00
200 Tractor Feed Labels	£4.00

AMIGA 1500/2000 PERIPHERALS

G.V.P. 42Mb Fast Access Hard Drive with 8Mb Unpopulated RAM board	£314.99
FREE next day delivery	
G.V.P. 80Mb Fast Access Hard Drive with 8Mb Unpopulated RAM board	£379.99
FREE next day delivery	
G.V.P. 120Mb Fast Access Hard Drive with 8Mb Unpopulated RAM board	£454.99
FREE next day delivery	
G.V.P. A1500/A2000 8Mb RAM board populated with 2Mb RAM	£159.99
2Mb SIMMS to fit the above GVP's	£59.99
(fitted FREE if required)	

AMIGA CONTROL CENTRES

These are the original and best. Manufactured by Premier Micros from Sheet Steel with welded seams and Epoxy coated to colour match the Amiga. Precision made to fit over the back of the Amiga to make a perfect platform for a monitor, improve the looks of the Amiga and provide space for a second drive etc.

A500/A500 Plus Model	£39.95
A600 Model	£34.95
Amiga 1200 Model	£39.95

DUST COVERS

Top quality Amiga Colour Dust Covers, Tailored, Monogrammed and with Bound Edges.

Protect Your Investment

Amiga 500 Keyboard	£4.99
Amiga 600 Keyboard	£4.99
Amiga 1200 Keyboard	£4.99
Citizen 120D Printer	£4.99
Citizen Swift 9/24/124D	£4.99
Commodore Monitor	£4.99
Philips Monitor MK II	£4.99
Amiga 1500 Two Part Cover	£8.99
Star LC10 Printer	£4.99
Star LC200 Printer	£4.99
Star LC24/200 Printer	£4.99
Amiga 500 with Control Centre & Monitor Combined Cover	£8.99
Amiga 600 with Control Centre & Monitor Combined Cover	£8.99

DISK DRIVES & EXPANSIONS

CUMANA CAX354 1Mb 3.5" Single disk drive - Enable/Disable switch - Thru port - Power ex Amiga

REPLACEMENT A500 Internal Disk Drive, fully compatible and with full instructions	£46.99
MEMORY EXPANSIONS & SYSTEM UPGRADES 512k RAM Expansions with Clock and On/Off Switch	£26.99
1Mb MODULE FOR A500 PLUS gives 2Mb Chip Memory	£44.99
AMIGA 600 - 1Mb Chip RAM Module with clock, plugs into trapdoor underneath the A600	£44.99
KICKSTART ROMS	
V1.3 Kickstart ROM	£29.99
V2.04 Kickstart ROM	£49.99
ROM SHARER	
2 Position Switch	£19.99
SMART CARDS FOR PCMA SLOT IN AMIGA A600 and A1200	
2Mb Ram Expansion Card	£129.99
4Mb Ram Expansion Card	£199.99

MULTIMEDIA

AMIGA CDTV MULTI MEDIA PACK
 Amiga CDTV player complete with keyboard, mouse, Amiga disk drive, infra red remote controller, batteries, welcome disks, Lemmings, & Hutchinsons Encyclopaedia

AMIGA CDTV
 Amiga CDTV player, infra red remote controller, welcome disks, Lemmings, & Hutchinsons Encyclopaedia

Amiga CDTV player	£399.99
Keyboard	£49.99
Mouse	£39.99
Floppy Disk Drive	£54.99
Track Ball	£79.99

CD-ROM DRIVE
 Commodore A570 CD Rom Drive, plugs into Amiga A500 Expansion Bus to run CDTV Software

NEW - PHILIPS CD-I

AMIGA 500/600 HARD DRIVES

G.V.P. 42Mb Fast Access Hard Drive with 8Mb Unpopulated RAM board	£334.99
FREE next day delivery	
G.V.P. 80Mb Fast Access Hard Drive with 8Mb Unpopulated RAM board	£428.99
FREE next day delivery	
G.V.P. 120Mb Fast Access Hard Drive with 8Mb Unpopulated RAM board	£499.99
FREE next day delivery	
2 x 1Mb SIMMS for above (Free fitting)	£59.99
G.V.P. COMBO 40Mhz Accelerator Plus 120Mb Hard Drive Plus 8Mb RAM board all in one case	£874.99
4Mb SIMM for above (fitted free if required)	£169.99

ZAPPO A500/A500+ Hard Drives - take up to 8Mb of 1Mb Simms, mouse operated Games Switch, SCSI through port, 12 month warranty.

ZAPPO A500/40Mb Hard Drive	£279.99
ZAPPO A500/60Mb Hard Drive	£329.99

2 x 1Mb Simms for above (FREE fitting)

2.5" IDE Hard Disks for Amiga A600/A1200 Simply fits inside your Amiga, complete with lead and fixing screws	
60Mb	£229.99
80Mb	£269.99

COMMODORE AMIGA SYSTEMS

FREE NEXT DAY DELIVERY ON ALL OUR AMIGA SYSTEMS

COMMODORE AMIGA A600 PACKS

PACK ONE
 AMIGA A600 SD BASIC PACK
 New Compact Design - Kickstart/Workbench 2.05, plugs directly into any T.V. 1Mb RAM, Smart Card Slot, 3.5" Built in Disk Drive, Complete with Mouse and PSU, 12 months in home service

PACK TWO
 AMIGA A600 HD BASIC PACK
 AS PACK ONE PLUS a 20Mb Built in Hard Disk Drive, installed with Workbench 2.05

PACK THREE
 The Wild, the Weird & The Wicked. AS PACK ONE, with Deluxe Paint III. GRAND PRIX by (MicroProse) PUTTY by System 3, PUSHOVER by Ocean and Deluxe Paint III

PACK FOUR
 EPIC/Language lab, Hard Drive Pack. AS PACK TWO, with Trivial Pursuit in three different languages, Amiga text, Word Processor, EPIC by Ocean, ROME by Millenium, and MYTH by System 3

PACK FIVE
 Home Office Pack.
 The complete all in one package for your home or business, Commodore Amiga 600 as PACK ONE with word processor, 50,000 word spell checker database spreadsheet with graphics, disk manager

COMMODORE AMIGA A1200
 32 bit graphics, Kickstart/Workbench 3.0, plugs directly into any T.V. Smart Card slot, 2Mb chip RAM 3.5" built in disks drive. Complete with Mouse and PSU. 12 Months In Home Service

As above with 60Mb Internal Hard Drive. Fitted under warranty by our technical department

COMMODORE AMIGA 4000
 The power of the 68060 32-bit processor running at 25Mhz, new double A4 graphics chip set and 16.8 million colours. High density disk drive, High speed 120Mb IDE Hard Drive, New Workbench v3.0

ESSENTIAL ACCESSORIES PACK
 Top quality 40 disk storage box, 10 best quality disks with labels, mouse mat, tailored monogrammed dust cover, SPECIAL PRICE £21.99 or £19.99 when purchased with any Amiga system.

ZOOL PACK
 ZOOL, Pinball Dreams, Striker, Transwrite, RRP over £127 only £20.00 with any Amiga system.

PRINTER RIBBON RE-INK

Simply open your plastic ribbon case, spray over the ribbon, replace the lid and leave for 24 hours.
BETTER THAN A NEW RIBBON
 Guaranteed - Restores dozens of ribbons to new for just

PRINTERS

We are CITIZEN SUPER DEALERS and Authorised to offer their Full 2 years Guarantee on all CITIZEN Products. This Guarantee covers all parts and labour including Printer Head.

FREE WITH ALL OUR PRINTERS:
 Exclusive Printer Starter Kit
 Comprising:
 * 200 Sheets Quality Paper
 * 200 Sheets Continuous Paper
 * 200 Tractor Feed Address Labels
 * 2 Metre Amiga Printer Cable
 * Special Amiga drivers disk to match your Amiga perfectly to any of our printers
 Free next working day delivery on all Printers

NEW CITIZEN SWIFT 2 SERIES
 Whisper quiet - very fast - 2 year warranty
CITIZEN SWIFT 200 -
 24 pin colour

NEW STAR LC 100 SERIES
 STAR LC100 - 9 pin colour

INKJET PRINTERS
 CITIZEN PROJET

INKJET CARTRIDGES
 CANON BJ10E Ink Cassette

EPSON PRINTERS
 EPSON LX400

MONITORS

PHILIPS CM8833 MK II Stereo Colour Monitor High Resolution, Free Lotus Turbo Challenge 2 Game, leads and on-site Warranty

Philips Tilt & Swivel Stand for the above

New COMMODORE 1084ST Stereo Colour High Resolution, PC Style Monitor, mounted on a Tilt and Swivel Stand, Colour matched to Amigas A600/A1200, includes leads, 12 months warranty

FREE NEXT WORKING DAY DELIVERY ON ALL OUR MONITORS FREE STEREO SOUND AND RGB CONNECTING CABLES.

Please note that all our Monitors are official UK specifications. We do not sell Grey imports of any kind.

GOLDEN IMAGE NAKSHA ABACUS SEGA DIGITA PANASONIC JVC MITSUBISHI EPSON CANON TOSHIBA HEWLETT PACKARD GOLDSTAR ZYDEC

12.00 Midnight

AMIGA BOOK SPECIALS

Amiga Applications	£16.95
Amiga Basic Inside and Out	£18.95
Amiga C for Beginners	£16.95
Amiga Desktop Video Guide	£16.95
Amiga Desktop Video Power*	£24.95
Amiga Desktop Video Workbook*	£29.95
Amiga DOS a Dabhand Guide	£14.95
Amiga DOS Inside & Out	
Revised Edition with Disk	£29.95*
Amiga DOS Reference Guide 3rd Ed	£18.95*
Amiga DOS Quick Reference	£8.95
Amiga DOS 2 Companion	£22.95
Amiga Intern	£32.95
Amiga for Beginners - new version W/B 1/3 & 2.0	£12.95
Amiga Graphics Inside & Out	£29.99
Amiga Game Makers Manual	£16.95*
Amiga Machine Language	£14.95
Amiga Printers Inside & Out	£29.95*
Amiga Programmers Handbook Vol 2	£22.95*
Amiga ROM Kernel Ref Manual 3rd Edition Devices	£24.95*
Amiga ROM Kernel Ref Manual 3rd Edition Includes and Autodocs	£32.95*
Amiga ROM Kernel Ref. Manual 3rd Edition Libs	£32.95*
Amiga Hardware Ref. Manual 3rd Edition	£24.95*
Amiga 3D Graphics Programming In BASIC	£16.95
The Best Amiga Tricks and Tips*	£24.95
C: A Dabhand Guide	£14.95
The Commercial Games Programmers Guide	£11.95
Get The Most Out of Your Amiga Vol 2	£9.95
Get The Most Out of Your Amiga Vol 1*	£13.95
Inside Amiga Graphics	£16.95
Kids and the Amiga - 2nd Edition	£14.95
Learning To Fly with Flight Sim	£12.95
Making Music on the Amiga*	£29.95
Mastering Amiga Beginners	£19.95*
Mastering Amiga DOS 2 - Vol 1	£21.95
Mastering Amiga DOS 2 - Vol 2	£17.95
Mastering Amiga Primers	£19.95*
Mastering Amiga System	£29.99*
Mastering Amiga Workbench 2	£19.95
Mastering Amiga Amos	£19.95
More Amiga Tricks and Tips	£14.95*
Screen Play 2	£9.95
Using AREXX on the Amiga Plus*	£29.95
Using Deluxe Paint - Second Ed	£18.95

* With FREE disk

SERIOUS SOFTWARE

Wordworth version 2.0 from Digita	£74.99
Scala 500	£89.99
Scala (Needs 1.5Mb Ram & Hard Drive)	£159.99
Pen Pal	£39.99
GB Route Plus	£59.95
Design Works	£57.99
Quarterback	£46.99
Quarterback Tools	£59.99
Home Accounts	£19.99
Home Accounts 2	£36.99
X-Backup Pro	£35.99
Amos	£32.49
Amos Compiler	£19.49
Amos 3D	£21.49
Easy AMOS	£25.99
Amos Professional	£55.99
Pagestream 2.2	£139.99
NEW Final Copy II	£89.99
Art Department Professional	£179.99
Introcad	£49.99
Professional Calc	£129.99
Professional Page v3.0	£109.99
NEW Mini Office Wordprocessor, 50,000 Word Spell Checker, Database, Spreadsheet, Disk Manager & Graphics RRP	£59.99 Special Offer
Junior Typist	£12.99
Gold Disk OFFICE v2	£44.99
Deluxe Paint IV aa	£89.99
Publishers Choice	£32.49

MIRACLE PIANO TEACHING SYSTEM

Professional Midi Compatible 49 key keyboard with unique Piano Teaching System. Record, Overlay and mix your own creations with the Miracle's 8 Track Studio. With 250 lesson software, cables, earphones, footpedal and manuals. **PLAY THE PIANO IN 3 WEEKS**
Complete System£289.00

You are welcome to visit our NEW 4000sq ft Super Store in Kettering, or visit our extensively stocked Stamford Shop.

EDUCATIONAL SOFTWARE

Fun School 2 - Under 6's	£7.99
Fun School 2 - 6 to 8's	£7.99
Fun School 2 - Over 8's	£7.99
Fun School 2 - 8 and Over	£12.45
Fun School 3 - Under 5	£15.45
Fun School 3 - 5-7 Years	£15.45
Fun School 3 - 7 and Over	£15.45
Fun School 4 - Under 5	£16.45
Fun School 4 - 5-7 Years	£16.45
Fun School 4 - 7 and Over	£16.45
ADI Maths 11/12	£19.99
ADI Maths 12/13	£19.99
ADI English 11/12	£19.99
ADI English 12/13	£19.99
ADI French 11/12	£19.99
ADI French 12/13	£19.99
ADI Junior Reading 4/5	£19.99
ADI Junior Reading 6/7	£19.99
ADI Junior Counting 4/5	£19.99
ADI Junior Counting 6/7	£19.99
Paint 'N' Create 5 years+	£22.99
Merlin's Maths 7 - 11 years	£22.99
Spelling Fair 7 - 13 years	£22.99

KOSMOS

Answer Back Junior	£14.45
Answer Back Senior	£14.45
Fact File 500 - 20th Cent. History	£7.95
Fact File 500 - General Science	£7.95
Fact File 500 - Know England	£7.95
Fact File 500 - English Word	£7.95
Fact File 500 - Natural History	£7.95
Fact File 500 - World Geography	£7.95
Fact File 500 - First Aid	£7.95
Fact File - Spelling	£7.95
Fact File - Sport	£7.95
Fact File - Arithmetic	£7.95
Fact File - Association Football	£7.95
The French Mistress	£14.45
The Italian Tutor	£14.45
The German Master	£14.45
The Spanish Tutor	£14.45
Maths Adventure	£19.99

L.C.I.

Micro English (GCSE)	£18.95
Micro French (GCSE)	£18.95
Micro Maths (GCSE)	£18.95
Micro German (GCSE)	£18.95
Mega Maths (A Level)	£18.95
Primary Maths (3-12)	£18.95
Reading and Writing (3-8)	£17.95

MISC

Better Spelling (8-Adult)	£16.99
Junior Typist	£12.99
Better Maths	£16.99
Noddy's Playtime	£19.99

NEW DELUXE PAINT III TUTOR VIDEO

Learn to get the best from NEW Deluxe Paint III. This video shows you how to design and execute your own Animations, Titles and so much more in a Step-By-Step, Easy-To-Follow way.

Subjects covered include:

- ★ Screen Painting
- ★ Zoom
- ★ Colours
- ★ Working with Text and Fonts
- ★ Stencils
- ★ Perspective
- ★ Animation
- ★ Video Titling etc, etc



RUNNING TIME: NEARLY THREE HOURS!!

Superb Value At ONLY £18.99 inc Post & Packing

"I was a little sceptical about the chances of taking a complete beginner to such artistic heights but I must admit to being wrong"
AMIGA COMPUTING, September 1991

ACCESSORIES

Audio Leads - connect your Amiga to your Hi-Fi		Midi Connector, Midi Leads & Free Music X Junior	£39.99
3 Metre Stereo Audio Leads	£4.99	Quickjoy Foot Pedal	£24.95
Quality Soft Mouse Mat	£2.99	Voltmace Delta 3A	
Mouse Bracket (to hold mouse)	£1.99	Analogue Joystick	£12.99
3.5" Disk Drive Head Cleaning Kits	£1.99	Gravis Clear - The Joystick	£36.99
Twin Joystick/Mouse Extension Lead	£5.99	Zipstick Superpro Autofire Joystick	£12.99
Joystick/Mouse "Y" Lead	£5.99	Sigma Ray (Pistol Grip - Auto Fire)	£13.49
Joystick/Mouse Switch Box (not 600)	£9.99	SpeedKing Analogue Hand Held Joystick	£14.99
Joystick/Mouse Auto Sensing Switch Box by Robo	£16.99	Mouse pad/mouse pocket - Gift Pack	£4.99
Aerial Switching Boxes, fit in TV lead to eliminate constant disconnection and wear on TV	£3.99	Optical Mouse	£34.99
Surge Protection Plugs	£11.99	Desk Top Copyholder. Makes typing and inputting easier	£9.99
Printer Cables	£7.99	Space Saver Copy holder. Moving arm, clamps to edge of desk	£17.99
Modulator Extension Lead stops your Modulator falling out!!! Plugs into Modulator port and Modulator and allows Modulator to sit along the back of the Amiga instead of projecting. Approx 12" cable length	£10.99	Printer stand. Fits any printer	£7.99
Naksha Mouse with FREE Mouse Mat, FREE Mouse Holder and Operation		3 Metre Joystick OR Mouse Extension Lead	£5.99
Stealth Game	£25.99	Primax 350 DPI Mouse	£14.99
Itsa Mouse - 280 DPI Microswitched	£14.99	Alpha Data Scanner - Scan & Save	£124.99
Techno-Plus Mouse		Alpha Data Scanner - Touch Up	£149.99
Microswitched 300DPI!!	£17.95	Naksha Scanner - plugs in side expansion	£99.99
GVP DSS8 - Digital Sound Studio		Mega Mouse	£14.95
Sound Sampler	£57.95	Power Scanner V3	£109.99
		Monitor Arm, clamps on edge of desk, creating additional work space	£34.99



DEPT AF, 3 STATION ROAD, KETTERING, NORTHANTS NN15 7HH. SHOP HOURS (0536) 414892
OUT OF HOURS (0780) 720531

VISA Access

TELEPHONE DIRECT TO OUR MAIL ORDER HOTLINE. ALL MAJOR CREDIT CARDS ACCEPTED. QUOTE YOUR NUMBER AND EXPIRY DATE. SAME DAY DESPATCH

SEND ALL FORMS OF PAYMENT MADE PAYABLE TO AUDITION COMPUTERS LTD. WITH YOUR ORDER PLEASE SEND YOUR NAME, ADDRESS AND DAYTIME TELEPHONE NUMBER ALONG WITH YOUR DETAILED ORDER REQUIREMENTS. GOODS WILL BE SENT BY POST, FREE OF CHARGE IMMEDIATELY AFTER CHEQUE CLEARANCE

ALL OUR PRICES INCLUDE FREE STANDARD DELIVERY ON ALL ORDERS OVER £15.00. ORDERS UNDER £15.00 MUST INCLUDE £2.00 SMALL ORDER CHARGE. NEXT WORKING DAY DELIVERY ONLY £2.50 EXTRA ON ALL ORDERS OVER £100.00

MINIMUM ORDER £15.00 else surcharge £2.00

ALL OUR PRICES INCLUDE V.A.T.

◆ Discover the



Your computer, your creativity and *Future Music* are all you need to enter the fascinating world of making music. We'll guide you to the right software and hardware at the best prices, then show you how to get the most out of them.

Every month we will open up for you the entire world of music technology, from creating and playing live to recording and producing. Your computer can be the starting point for making superb music – STs, Amigas, Macs and PCs are all at the hub of making music today.

We won't swamp you with jargon and technical drivel because we know just how confusing the business of music technology can be. You'll get clear, concise and entertaining reviews and features, written by experts who know what they're talking about and can show you how to do it too.

Find out just how exciting creating music can be. *Future Music* issue three is at your newsagent now!



◆ News pages packed with previews, personalities, the latest launches, opinions, updates and events



◆ Informative interviews with performers and sound crew

Don't miss the third issue of **Future Music** in all good newsagents NOW

world of music

Take control of your music!



◆ Expert technical advice on all your musical problems every issue



◆ Authoritative reviews of all the latest hardware and software

Technology plus creativity

Don't just listen - play!



◆ Comprehensive buyers' guides to hardware and software

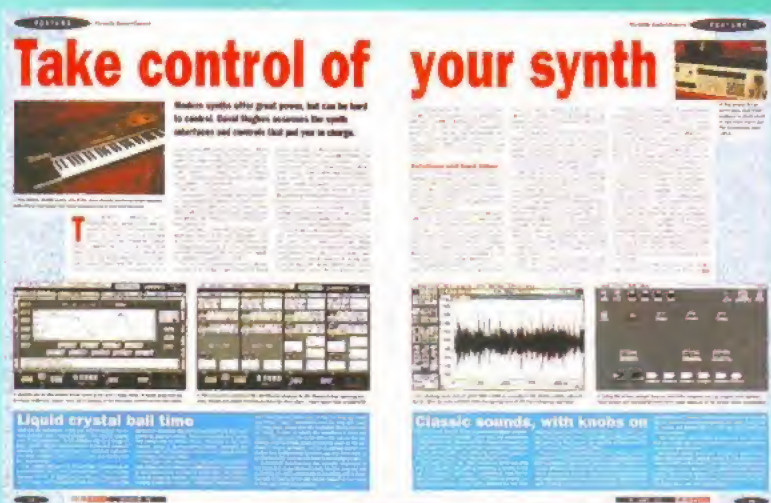

◆ How to... guides that will help you get the most from your gear

Issue 3
out NOW

**FUTURE
MUSIC**

The technology for making music is becoming increasingly affordable, giving more people than ever the access to equipment that can create, play and record to a high quality level. What you need to know is what equipment is right for you and how to get the most out of it. We will guide you through this

complicated world - ripping out needless jargon, giving authoritative reviews, providing essential advice and keeping you up to date with everything to do with music technology. Join us every month and be part of a unique club of music enthusiasts.

PLUS
2 PACKED COVERDISKS
and a
100-PAGE TIPS BOOK
with this issue

IT'S EASY WHEN YOU KNOW HOW

Don't let the PC get you down - discover how to get the very most out of it with our complete **Beginners' guide**.

Look what's on offer:

- Get to grips with DOS - what are system files? How can you make DOS work the way you want it to?
- Upgrading your PC - what's possible and how can you do it?
- What hardware can you add to your machine to improve its performance?
- Discover what goes on under the bonnet - we explain what all the different bits and pieces do.
- Tips galore - everywhere you turn there are special beginners' tips throughout the issue.
- 20 of the best games of the last year.



PC FORMAT
Expect the unexpected!

DON'T MISS THE NEXT ISSUE OF PC FORMAT OUT ON CHRISTMAS EVE

PUBLIC APOLOGY

1993 - we will start as we mean to go on. As ever, we will be offering highest quality goods at the best possible prices.

3.5" DSDD PLUS BANX STACKABLE BOX

50 DSDD 3.5" plus Banx Box.....	£32.00
100 DSDD 3.5" plus Banx Box.....	£46.00
150 DSDD 3.5" plus 2 Banx Boxes	£70.00
240 DSDD 3.5" plus 3 Banx Boxes	£108.00
320 DSDD 3.5" plus 4 Banx Boxes	£148.00
400 DSDD 3.5" plus 5 Banx Boxes	£180.00

BANX BOXES ARE STACKABLE, HORIZONTALLY AND VERTICALLY, LOCKABLE AND BEAUTIFULLY MADE

3.5" DSDD PLUS DELUXE BOXES

50 DSDD 3.5" plus Deluxe Box	£27.50
100 DSDD 3.5" plus Deluxe Box	£44.95
150 DSDD 3.5" plus 2 Deluxe Boxes	£57.00
200 DSDD 3.5" plus 2 Deluxe Boxes	£76.95
400 DSDD 3.5" plus 4 Deluxe Boxes	£145.00
500 DSDD 3.5" plus 5 Deluxe Boxes	£178.00

ALL DISKS CERTIFIED 100% ERROR FREE AND SUPPLIED WITH LABELS. BOXES ARE LOCKABLE ANTISTATIC WITH AMPLE DIVIDERS

LOOK

ULTIMATE A1200 PACK

The most comprehensive and best value pack ever.
HERE'S WHAT YOU GET

	RRP
NEW A1200 COMPUTER.....	£399.99*
ZOOL PACKAGE WORTH	£127.92*
(Includes Zool, Striker, Pinball, Dreams, Transwrite).	
100 'A' Grade 100% Certified 3.5" disks	£40.00*
Banx Deluxe Stackable Box	£11.95*
Deluxe 8mm Mouse Mat.....	£3.95

3.5" Diskette Head Cleaner	£3.95
Tailor Made Dust Cover	£3.95
Clip on Copy Holder	£6.95
TOTAL	£598.66

OUR ULTIMATE PRICE.... £439.95

*When purchased separately

BANX stackable disk boxes

Exclusive to us, these disk storage boxes are superior to many we've seen costing more than twice as much. Beautifully constructed in best quality materials with a smooth-running drawer. Supplied with four colour-coded dividers and fittings to stack horizontally or vertically. Available in two sizes. The Dual Format version is also ideal for compact disks.

3.5" 80 + DISK CAPACITY £11.95
MULTI BUY DISCOUNTS
3-4 £8.95 EACH 5+ £8.50
DUAL FORMAT
180 5.25" disk capacity
or 130 3.5" disk capacity
£16.95

EXCLUSIVE!

READER OFFER - 100 HD 3.5" Disks PLUS BANX STACKABLE BOX for the incredible price of only £74.95

18 Crescent Way, Orpington, Kent BR6 9LS

***ALL COMPUTERS SPECIAL FREE SUPERFAST DELIVERY**

All orders subject to availability. Prices include VAT

M D
OFFICE
SUPPLIES

Free post & packing on orders over £20.00

Orders below add £2.95

TEL : 0689 861400

FAX : 0689 850628



SCHOOL'S

IN



EURO PRESS
SOFTWARE

EDUCATIONAL SOFTWARE

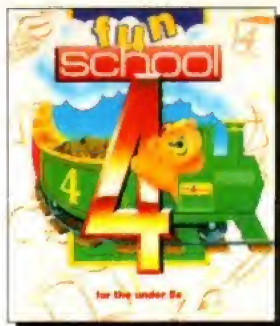

FUN SCHOOL 4
For the under 5's.



FUN SCHOOL 4
For 5 to 7 year olds.

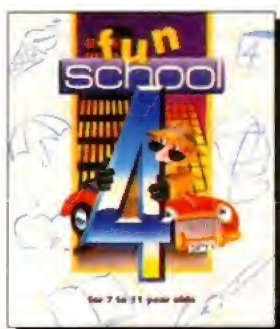

FUN SCHOOL 4
For 7 to 11 year olds.

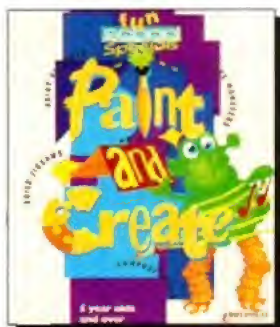

FUN SCHOOL SPECIALS
Paint and Create.
5 year olds and over.



FUN SCHOOL SPECIALS
Merlin's Maths.
For 7 to 11 year olds.

Parents of the world, rejoice.

Your child might soon be dashing home from school to reach not for the latest megakiller computer game, but for their homework.

It's no dream, thanks to Europress educational software.

We heard how worried you were to read what so many people are saying about falling standards in schools. And we saw just how much children loved computer games at home.

So we sat down and created the best of all possible worlds: an action-packed range of educational software that's so compelling, homework will give even Ninja Turtles a run for their money.

Naturally, every title in the range follows the guidelines of the National Curriculum to the letter, but engages the imagination of your child to the full.

Our Fun School range covers stacks of general topics, while the Fun School Special packs focus on subjects such as Maths and Spelling.

For GCSE children, our ADI range is every bit as entertaining but has a more academic approach.

ADI covers English, Maths and Le Français and helps children sail through their exams with the greatest of ease. And now ADI Junior gives tots as young as four the start they need to make reading and counting as easy as 1, 2, 3.

Europress. We've started a new trend in education. To learn more, and about formats available, please contact us at the address below.

europress
SOFTWARE

CREATIVE EDUCATION

Europress Software, Europa House, Adington Park, Macclesfield, SK10 4NP.
TEL: Technical/Admin: 0625 859333. FAX: 0625 879962.



FUN SCHOOL SPECIALS
Spelling Fair.
For 7 to 13 year olds.

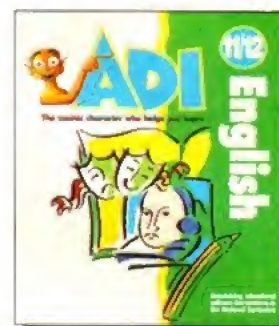

ADI ENGLISH
For 11 to 15 year olds.

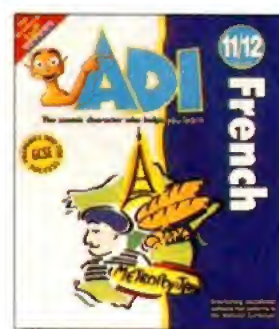

ADI FRENCH
For 11 to 15 year olds.

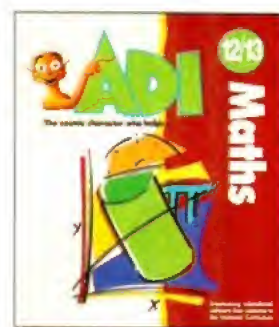

ADI MATHS
For 11 to 15 year olds.

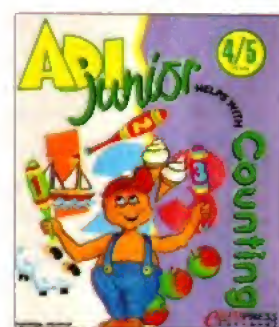

ADI JUNIOR COUNTING
For 4 to 7 year olds.

WeServe of Hampshire Established 7 years

High quality products. Full technical support.

High quality products. Full technical support.

<p>Amiga Workstation /Expansion System Monitor stand with shelf for drives etc. Strong metal construction made from 14SWG steel epoxy coated. No Cables or mouse are included. Special price £27.50</p>	<p>Midi Interface 4 channel Midi interface for Amiga £19 Dr T's Midi Music S/w (A500 only not Plus) £4.95</p>	<p>New Prices</p>	<p>Floppy Drives</p>
<p>New Citizens Swift 240 24pin Colour * Advanced 24pin printer, (Swift 24E replacement). Phone for a data sheet *optional colour. Price with cable & paper 240 Mono £245 240C Colour £265</p>	<p>Deskjet 500 HP 300dpi Inkjet printer. Laser quality at dot matrix price. 3 year warranty. With cable & paper £325</p>	<p>GVP Series 2 Hard Disks for A500 80Mb Hard Disc £379 120Mb Hard Disc £419 240Mb Hard Disc £689 80Mb A530 Combo £649 120Mb A530 Combo £749 240Mb A530 Combo £989</p>	<p>Cumana CAX354 1M external While stocks last £49.90</p>
<p>Swift 200 24pin Colour * Enhanced 24pin printer, (Swift 224 replacement.) Phone for a data sheet *optional colour. Price with cable & paper 200 Mono £195 200C Colour £219</p>	<p>Deskjet Colour 300dpi colour inkjet printer. Colour laser quality at 1/10 of the cost. 3 year warranty. With cable & paper £419</p>	<p>for A1500 80Mb Hard Disk £339 120Mb Hard Disk £399 240Mb Hard Disk £629 GVP ram £41 per 1Mb</p>	<p>Commodore A1011 1M external While stocks last £48</p>
<p>Citizen's Print Manager These advanced printer drivers transform colour printouts to laser type quality Version 1 (224 & 24E) £5 Version 2 (Swift series 2) £10 Drivers 1/2 price if bought with a printer</p> <p>Printer Drivers Canon BJ-10e/lex £5 Deskjet 500 Colour £10</p>	<p>New HP Deskjet 550C 300dpi colour inkjet printer. Colour laser quality, with colour and black cartridges resident. 3 year warranty. With cable & paper £529</p>	<p>Ram Upgrades A500 1Mram + clock £24.90 A500 1Mram no clock £19.90 A500 + 1Mram + clock £39.90 A600 1Mram + clock £49.90</p>	<p>Roctec/Zappo New All Amigas A500-A1200 1M external drive £49.90</p>
<p>Printer Packs All printers are supplied with a printer pack consisting of printer paper and a connection cable. Free of charge A stand is £5.00 extra (with a printer)</p>	<p>Printer Dust Covers most types in stock from £4.70</p>	<p>Citizen ProCM 14" Super High res. Multisync Colour monitor, dot pitch 0.26mm, suitable for A3000 or A4000 with cable £349</p>	<p>Amiga A1200 5x faster. Workbench v3. 2M ram. Custom graphics - 256K colours from 16.7 million. £359</p>
<p>Citizen 120D + with cable & paper £109 All Citizen printers have 2 year warranty</p>	<p>Printer Dust Covers most types in stock from £4.70</p>	<p>Philips CM8833 MK2 Rebadged as AKF17 14" Stereo Colour Monitor. Dot pitch 0.42mm. Medium Res. £165 with cable £169 without cable</p>	<p>Amiga A4000 25MHz 6Mram Wb 3 120Mb Hd £2099</p>
<p>Citizen Swift 9 with cable & paper Mono £155 Colour £179</p>	<p>Canon BJ-10ex 360dpi Inkjet printer with cable & paper £199</p>	<p>Philips CM8833 MK2 UK. 240V £219 with cable + game £215 without cable If game not required reduce above prices by £5.00 Price valid for current stock only</p>	<p>Amiga A600 Standard A600 single floppy £265 without software</p>
<p>Panasonic KXP1123 Probably the best 24pin mono printer available. With cable & paper £169</p>	<p>Star SJ-48 360dpi Inkjet printer with cable & paper £199</p>	<p>Commodore 1084SD 14" Stereo Colour Monitor. Dot pitch 0.42mm. Medium Res. £179 with cable £175 without cable Price valid for current stock only</p>	<p>Amiga 600SD (D.Paint III, Grand Prix, Putty, Pushover) Wild Weird & Wicked £305</p>
<p>Panasonic/Epson KXP1170 9pin 134 KXP1124i 24pin 215 KXP2180 9pin Colour 189 KXP2123 24pin Colour... 229 Epson LX400 9pin 119 Epson LQ570 24pin 265 Prices include VAT cable & paper</p>	<p>Star LC100 9pin colour with cable & paper £159</p>	<p>Philips CM8833 MK2 with cable £219 without cable £175 Price valid for current stock only</p>	<p>Amiga 600HD (Trivial Pursuit, Epic, Rome, Pushover) Epic Pack £435</p>
<p>Naksha Scanner with touch up software £109</p>	<p>Star LC20 Mono 9pin 119 LC200 Colour 9pin 175 LC2420 Mono 24pin 185 LC24100 Mono 24pin 175 LC24200 Colour 24pin .. 249 Prices include VAT cable & paper</p>	<p>Accessories 3M Joystick/Mouse lead 3.75 A500 Printer cable 7.95 Modulator/Disk Extension 10.95 23way Plug or socket 2.95 A500 Dust Cover 4.70 Mouse Mat (thick soft type) .. 4.95 Mouse House 2.95 1M internal 3.5" drive 49.00 A500 replacement PSU 39.00 A590 replacement PSU 49.00 Rocgen Plus - Genlock + ... 129.00 Disc Wallet for 32 disks 7.95</p>	<p>SONY DISKETTES SONY branded (lifetime warranty) (100% certified error free) 10x 3.5" DS/DD 135tpi 7.50 50x 3.5" DS/DD 135tpi 32.30 100x3.5" DS/DD 135tpi 59.93 250x3.5" DS/DD 135tpi 141.00 1kx 3.5" DS/DD 135tpi 540.50</p>
<p>Naksha Mouse for Atari ST & Amiga with house & mat £21.50</p>	<p>Kickstart Upgrades Commodore 2.04 full upgrade 79.00 Kickstart ROM only v2.04 41.50 Kickstart ROM only v1.3 29.00 Phoenix rom sharer 24.95 Keyb'd operated rom sharer 24.95 VXL30 25MHz Accelerator ...239.00 Fatter Angus custom chip 37.50</p>	<p>Accessories 3M Joystick/Mouse lead 3.75 A500 Printer cable 7.95 Modulator/Disk Extension 10.95 23way Plug or socket 2.95 A500 Dust Cover 4.70 Mouse Mat (thick soft type) .. 4.95 Mouse House 2.95 1M internal 3.5" drive 49.00 A500 replacement PSU 39.00 A590 replacement PSU 49.00 Rocgen Plus - Genlock + ... 129.00 Disc Wallet for 32 disks 7.95</p>	<p>SONY DISKETTES SONY / DYSAN bulk (lifetime warranty) (100% certified error free) 10x 3.5" DS/DD 135tpi 5.95 50x 3.5" DS/DD 135tpi 21.86 100x3.5" DS/DD 135tpi 39.60 250x3.5" DS/DD 135tpi 94.88 1kx 3.5" DS/DD 135tpi 379.53 40 x 3.5" Disk box with lock..... 5.49 100 x 3.5" Disk box with lock..... 7.50 Carrriage on 50 + disks £3.53</p>
<p>Squik Mouse for Atari ST & Amiga £13.90</p>	<p>True Mouse for Atari ST & Amiga £15.90</p>	<p>Happy Mouse for Atari ST & Amiga £14.90</p>	<p>Phone for our 60 page catalogue. All prices include 17.5% VAT EDUCATIONAL AND GOVERNMENT ORDERS WELCOME All products have a 30 day money back & 12 month warranty. Prices are subject to variation without prior notification. Please phone for express clearance of cheques. Established 7 years. 3 minutes from M27 Junction 11. Free parking. Open 9 to 5.30 Monday to Friday & 9 to 5 Saturday Postage 94p or £3.53 Securicor £6.46 (£5.50 + VAT)</p> <p>WeServe Larger items delivered by Securicor</p> <p>Amiga/Format Dept. 40-42 West Street Portchester Hants PO16 9UW Tel: 0705 647000</p>

Visit our showrooms. See before you buy.

Visit our showrooms. See before you buy.

Our review policy

Amiga Format has been voted 'magazine most influencing buying decisions' by dealers in trade magazine *Computer Trade Weekly* for three years running. That's because they know our reviews are the most trustworthy: what we say, you seem to agree with.

Simply enough, that's because a) we know what we're talking about, and b) we're honest. We know what you want, because we're Amiga enthusiasts ourselves. And because we're Amiga experts, we test everything to the full and see how it performs.

If something is let down by poor features, if it's difficult to use or if it's overpriced, we'll tell you. But on the other hand, if it's well worth the price or does something amazing we'll make you aware of that – and look out for the *Amiga Format* Gold award which distinguishes a truly excellent product, one that really stands out from the crowd.

How the Rating System works

SPEED (marked out of 5) ●●●●●

Tremendously important for both hardware and software: there's nothing more annoying than waiting. A purely intuitive judgement.

DOCUMENTATION (out of 5) ●●●●●

Although there are some packages that are so simple that no manual is needed, complex items benefit hugely from a good explanation.

ACCESSIBILITY (out of 5) ●●●●●

The target for all good software should be powerful but simple: this rating assesses how easy it is to get to grips with the item.

FEATURES (out of 5) ●●●●●

Does it do what you want it to do? How well does it do it? And does it also do lots of other things that you'd never have thought of?

VALUE (out of 5) ●●●●●

A pretty important rating, this one: if a package does everything you could wish for, it's no use to you unless you can afford to buy it.



The Verdict, our at a glance overall rating, is a percentage: it's based on sheer quality, but with price taken into account, so that you know what kind of a deal you get.

Let's get serious!

Neil Jackson sets out the bill of fare for the 'serious product reviews'. Be sure to look out for an exciting new printer idea and a new program for star gazing...

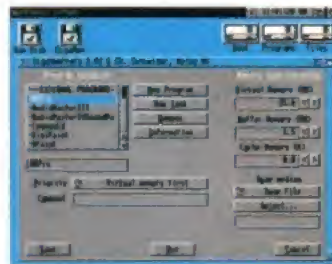

Memory GIGAMEM

So you thought that all the advantages of extra processing speed were only for the wealthy who could afford accelerator cards, did you? Here's a new piece of software that provides the Amiga with all the advantages of 'virtual memory' – it's like having lots of extra RAM even if you don't. Discover its advantages on... **Page 144**

Graphics IMAGINE GUIDE

We've discovered that there's no computer to compare with the Amiga when it comes to 3D ray-tracing. Possibly the best 3D package to date is *Imagine*, but it can be difficult to get the best out of the program until you know your way around it. So what could be better than this excellent book to be your guide? **Page 146**

Graphics REAL THINGS: DOGS

Deluxe Paint puts animation at your fingertips, so we're told. All very well, but suppose you've never tried animation before? Suppose you're not very good at drawing? To the rescue comes the *Real Things* series, with animated 'clip art', this time based around the ever-popular domestic theme of canines. **Page 146**



Printers OKI LCD PRINTER

'What's an LCD printer?' you might well ask. Well, in quality and in price it's very similar to a laser printer, though the way it works is somewhat different. This is the first example of this kind of printer we've ever tested, and the results are surprisingly excellent. We put it to the ultimate test on... **Page 148**

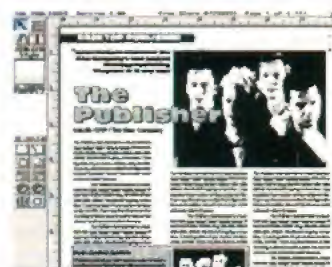

DTP THE PUBLISHER

Desktop publishing is one of the most satisfying things you can do with your Amiga and, fortunately for you, there's a number of companies that are competing for your money and producing excellent DTP software. This latest arrival from The Disc Company promises remarkable value, but how does it perform? **Page 150**



Astronomy DISTANT SUNS AND VOYAGER

Astronomy isn't one of the hobbies that you would normally think of as going hand in hand with computing and your Amiga. But think again, because here are two remarkable programs – one brand new, one updated – that will help you explore the wonders and mysteries of the night skies. There's a whole universe happening now and is waiting on... **Page 156**

Multimedia VIDEO MASTER



Innovation rules the roost, here. Microdeal have not only come up with the Amiga's first 16-bit sound sampler in the form of *Clarity 16* (due for release very soon), but have also created the first-ever combined sound sampler and video digitiser. So what does this bizarre combo have to offer? Find out on... **Page 136**

Music BOOM BOX



And here's another very original idea. Just because you have no real musical talent, that shouldn't prevent you from having a bash. Not when the Amiga makes it so easy. Dr T's have come up with a great intro to music for beginners and youngsters in the form of a play-along music creator that sets the backing tracks and lets you do the rest. **Page 140**

Do you need a video digitiser? How about a sound sampler as well? Why buy them separately when you can have them both in one box! **Jason Holborn** puts Microdeal's latest combination to the test...

VideoMaster

£69.95 ■ Video digitiser and sampler ■ Microdeal

WHILE SOME HARDWARE developers choose to diversify into different fields, others stick to doing exactly what they're best at. Take Microdeal, for example. They have been at the leading edge of Amiga sound products for several years now and their range of Amiga sound samplers is now second to none.

Yet sticking to what you do best doesn't necessarily mean you have to stagnate. Microdeal are on the verge of a whole set of innovative new products, not the least among which is Clarity 16, the first 16-bit high-quality sound sampler for the Amiga. We expected that we might be able to review it this issue, but a full review will hopefully appear in next month's magazine.

And the innovation continues with VideoMaster, the first ever piece of electronic wizardry to offer you the capacity to digitise both graphics and sound. It's an odd idea but one that makes good sense. Let's see how it performs under test...

One of Microdeal's most popular samplers to date has to be Amas 2, a combined sound sampler and MIDI interface in one compact (and almost bijou) box.

Although there are plenty of better sound samplers available on the market (RamScan's Audio Engineer, to name just one), no other sampler even comes close to Amas 2 in terms of giving the buyer value for money. Offering full-stereo sampling and MIDI compatibility to boot, Amas 2 continues to prove popular among Amiga musicians. Rumour has it that even pop idol Paula Abdul uses an Amiga that is equipped with an Amas sampler!

Spotting another obvious gap in the market, Microdeal have now opted for the 'combi' approach once again with the launch of their VideoMaster, a low-cost video digitiser and sound sampler for both the A500 and A500 Plus. Unlike any previous MicroDeal products, VideoMaster connects to the A500's 86-pin bus connector (the same connector that is used for hard drives) so I'm afraid the rest of us are out in the cold until MicroDeal choose to release a version that can be used on the rest of the Amiga range. A version for both the 2000 and 3000 is at the planning stage, but don't hold your breath.

The thing that makes VideoMaster so special, though, isn't the fact that it boasts both a digitiser and a sound sampler in one box. Certainly most other companies would have simply marketed the product as a low-cost

VIDEOMASTER is available from Microdeal 0726 68020

VideoMaster is a combi' digitiser and sampler. For under £70 you get your very own mini-multimedia workstation.



method of obtaining two extra add ons for your Amiga, but not Microdeal.

Instead they have cleverly managed to seamlessly tie the two products together and create a sort of 'integrated environment' for working with both sound and pictures simultaneously – you can more or less think of it as a mini-multimedia workstation, if you like. In effect, this is exactly what it is. When you think of the Amiga's obvious strengths in the multimedia market, it really comes as something of a surprise that no one has thought of bringing out such a combination before. Oh well, I suppose someone had to be first, and Microdeal are there.

It is fairly easy to set up VideoMaster, because once you've lodged its cartridge into the A500's bus connector, then you're ready to boot up the VideoMaster software and start digitising both sound and pictures.

The program is basically split into three different sections – there are two panels for controlling the video digitiser and sound sampler, and then there's a very powerful video sequencer which enables you to create your own multimedia movies, comprising sampled sound and animated frames. The VideoMaster digitiser is a real-time mono affair that can grab a series of frames from any composite

video source. The digitiser operates in two modes – either quarter screen or full screen.

Although full screen is perhaps the most useful of the two modes, quarter screen is far more practical simply because it enables VideoMaster to capture frames at a much higher rate – 25 frames per second as opposed to around four frames in full-screen modes. You will find that grabbing at 25 frames per second eats up RAM pretty quickly, but it produces some really impressive results.

Frame update can also be slowed right down using VideoMaster's very useful Time Lapse feature. Time Lapse can be used to grab a series of frames at specified intervals (one every two hours, for example). This can be particularly useful when digitising very slow-moving objects. VideoMaster can also capture single full-colour frames in one of two ways – using an RGB splitter or by placing a set of coloured filters (these are included) in front of a video camera (preferably black and white).

Like Rombo's Vidi-Amiga, VideoMaster stores each and every frame that it grabs into memory, forming a sort of digitised animation. Using VideoMaster's frame editor (which displays a series of five frames in miniature), you can then cut out and insert new frames with ease, enabling you to modify your animation to suit your needs. Several of these 'mini-

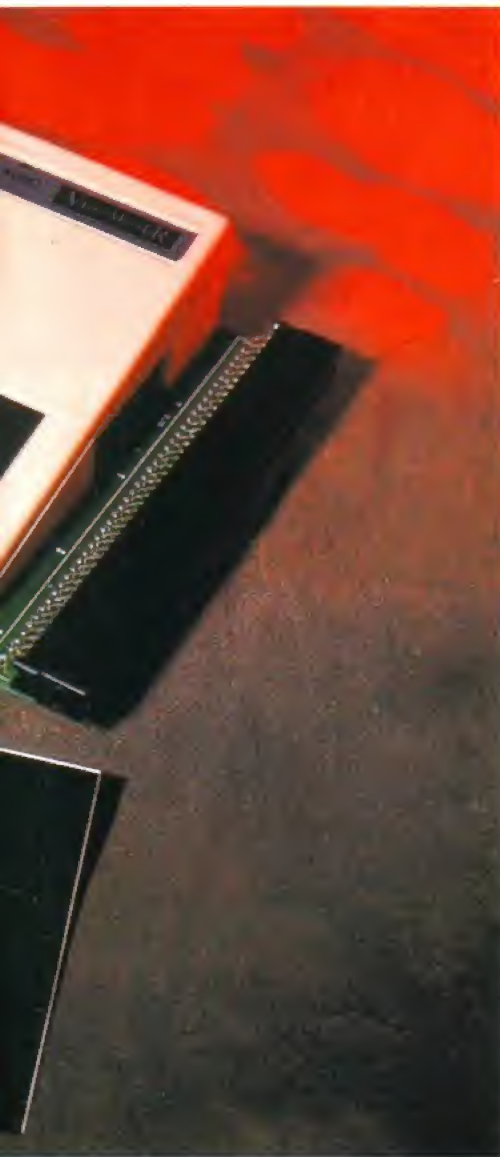
VIDEOMASTER AT A GLANCE



use a lower frame-grabbing speed if memory is a little tight. On an 8Mb Amiga, it's actually possible to grab over 1,000 of these frames (grabbed at 25 frames per second, that translates to 40 seconds of full-motion video!).



image from disk. Small sections of clip can also be isolated by grouping them into a block and then clicking on the 'Cut Rest' option. Alternatively, blocks can also be removed using the 'Cut Block' option.

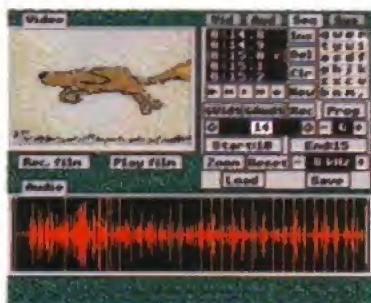

recorded into a single massive audio buffer with each sample separated from the rest by a set of two pointers that designate the start and ending points for the sample. Editing is a little basic though, so you may want to port your samples into a dedicated sample editing program for more comprehensive editing.



have to do is to assign each event (which can be either a video clip or a sample) to a key, click on 'Record' and then tap the appropriate key when you want the event to be played.

VideoMaster's digitiser is a fairly capable beast that can grab quarter screen images at rates of up to 25 frames per second. Obviously the number of frames that you can grab is restricted by memory, so it's best to

The video frame editor is used to remove or insert frames into a video clip grabbed using VideoMaster's digitiser. Each frame within the clip can have its own colour palette, so it's perfectly possible to load and use an IFF

Although the maximum audio sampling rate offered by VideoMaster is restricted to just 16 KHz, the sound quality is surprisingly high. If you already own a sound sampler, VideoMaster can use this instead. All your samples are

Finally we have the sequencer, which is the fun bit of VideoMaster. This enables you to construct your own films comprising video clips and sampled sounds. Constructing a sequence is a little like using a MIDI sequencer. All you

and VideoMaster records any key depressions in real-time. By tapping the same key in rapid succession, it's also possible to produce an impressive video 'stuttering' effect.

Samples are added to your film in exactly the same way. Each sample is assigned to a key and then you simply record the sequence again, pressing the sound keys to record the sample events into your sequence. If real-time recording is not accurate enough for you, then you can also add keyboard events in step-time mode using the sequencer's 'Insert' option. OK, it does sound pretty haphazard, but you'd be surprised to find just how easy it is to get some really impressive results. If you want to share your creations with your friends, MicroDeal kindly supply a standalone player program which can play your films from a separate disk.

There's no doubt that using VideoMaster is tremendous fun, but I can't help thinking that this is perhaps its only use - as a novelty rather than a serious tool for graphics, music or even multimedia work.

The full motion quarter screen-grabbing option could prove useful for CDTV developers though, because it provides an easy method of producing video footage suitable for CDXL (the CDTV's attempt at full-motion video). The sound sampler section isn't too bad either, but VideoMaster really is rather let down by the quality of its full-screen digitising. Although quarter screen grabs are full of detail, full-screen grabs seem washed out.

I keep on wanting to compare VideoMaster to standalone digitisers and sound samplers such as Vidi and even Microdeal's own Amas 2, but this isn't a particularly fair comparison to make simply because of the price difference between VideoMaster and the competition (the two products mentioned above would set you back £200!).

VideoMaster still represents astoundingly good value for money, though. Let's face it, what else can you buy these days for just £70? Sure, you could buy three games, but I can assure you that you'll have far more fun with VideoMaster! If your digitising needs aren't too serious, then you'll find VideoMaster is well worth investigating.

VideoMaster

SPEED	● ● ● ●
Grabbing and editing options are performed at a lightning-fast rate.	
DOCUMENTATION	● ● ●
Although visually nothing special, the VideoMaster manual is quite readable.	
ACCESSIBILITY	● ● ● ● ●
Plug it in, connect a sound and video source and you're away - it really is that simple.	
FEATURES	● ● ●
Doesn't pose a threat to dedicated samplers and digitisers, but it's a capable system.	
VALUE	● ● ● ● ●
Only £70 for a sound sampler and a digitiser can't be sniffed at.	

85%

CALLERS WELCOME AT OUR BRANCHES OPEN 9-5.30, MONDAY TO SATURDAY, (10-4.30 SUNDAYS ST ALBANS ONLY)

WARNING

Due to the exchange rate, many items in this ad will increase in price including IBM & Philips product. At the time of going to press we are unable to confirm the extent or date of the increases, therefore, all prices must be confirmed by telephone before ordering.

Hobbyte

COMPUTING
ESTABLISHED 8 YEARS

10 MARKET PLACE ST ALBANS
HERTS AL3 5DG TEL: (0727) 56005/41396
THE GALLERY ARNDAL CENTRE LUTON
BEDS LU1 2PG TEL: (0582) 457195/411281

HOW TO USE THIS AD
For the first time ever, you can choose your own Amiga and software combination, and still benefit from the huge savings only available from package deals. Want an A500 with 1500 software? No problem! Like an A1500 without games? It's up to you! All we ask is that you choose at least 1 software pack when you order your hardware (optional on CDTV, A1200, A3000 or A4000)

WE WANT TO BEAT ALL PRICES! CALL US!!

OLD AMIGA TRADE-IN

The best trade-in allowance, extra for peripherals and accessories. Trade in your old machine for a brand new A600/ A1500/1200/3000/4000/CDTV or even PC
A500's FROM £195
A1500's FROM £299
A limited number of refurbished A500/1500/3000s are available, complete with 3 months warranty.
Also, ask about refurbished printers, 590 and other hard drives, accelerators, monitors and peripherals.

AMIGA 500+ £254.95
A500+ with A570CD + PDCD£519.99
LIMITED NUMBER AVAILABLE - PHONE!

AMIGA 600
A600 with 12 month on-site warranty, 1MB, WB 2.05, 3.5" FD + Smart Card Interface, Mouse and Manuals
TRADE IN AVAILABLE
WITH 8833/CBM 1084 + ON-SITE

A600 ALONE	259.00	439.00
A600 20MB HD	419.00	599.00
A600 40MB*	469.00	649.00
A600 80MB*	494.00	674.00
A600 120MB*	594.00	774.00

2MB VERSION ADD £39.95
See below/across for alternative software packs
* Top quality 3rd party drives, covered by full 12 month return-to-base warranty

AMIGA 1500 inc. on-site
Full UK spec. with 1MB RAM, mouse, expansion as 2000, leads, manuals. New including Kickstart & Workbench 2.05. Hard disc configuration inc. the high performance GVP II controller card, EXPANDABLE TO 8MB

1500 SPECIALS
1/2 PRICE 1500 S/W PACK EXTRA This month, only with 1500, 1500 Pack Extra at only ...£24.99
1500 HD + ON-SITE, 8833/1084S, CITIZEN 200 24 pin col printer, 1500 Extra software pack, Starter Pack + AmigaVision 52MB£1149.00 120MB£1329.00

Per extra 2MB fitted to GVP ADD £60.00
Also with Kickstart 1.3 + ROM Sharer ADD £39.90
Also with Citizen 200 24 pin Col Printer + Starter Pack ADD £199.00

AMIGA 3000
12 MONTH ON-SITE MAINTENANCE
Latest version, 68030 25MHz, 3.5" 880K FD + spare drive bay (or 4 spare bays on Tower), 512K 32 bit ROM, 4 Zorro III, slots with 2PC AT slots (or 1 CPU, 7 Zorro III, 2 PC AT on tower), hard drive and memory as below:

DESKTOP	52MB	120MB	210MB	425MB
1MB video + 1MB Fast Ram	1289	1469	1729	2099
2MB video + 1MB Fast Ram	1437	1679	1929	2359
2MB video + 4MB Fast Ram	1549	1729	2099	2429
2MB video + 8MB Fast Ram	1729	1929	2299	2559

TOWER

1MB video + 4MB Fast Ram	2299	2549	2949
2MB video + 8MB Fast Ram	2449	2699	3199

With Multimedia Pack: AmigaVision, Deluxe Paint 4.1 and Scale ADD £195.99
With extra 4MB Fast RAM (fitted if required) ADD £169.99
With Philips SVGA 28dpi inc. tilt & swivel ADD £259.00

AMIGA 1200
2 MB, 68020 with new AGA chip set, 256,000 colours from 16 million colours plus on-site.
GET IT FIRST FROM HOBBYTE
NEW MID RANGE AMIGA EXPECTED WITH NEW CHIP SET, 68030 PHONE!

1200 5D	369.00
1200 60MB	599.00
1200 80MB	649.00

CDTV
1MB, with Disc Caddy, Welcome CD + tutorial + remote control unit.
AS ABOVE WITH MATCHING DRIVE KEYBOARD, MOUSE + WB 1.3

As above £369*
With Goldstar Black TV monitor + remote control £549*
Extra RAM EPOA

* Plus Hutchinsons Encyclopaedia + Lamings
See below/across for software packs

NEW PRICES!
ALSO WITH STARTER PACK £18.99 EXTRA

AMIGA 4000 MULTIMEDIA AMIGA
New AGA Chip Set + blistering 68040 processor, 256,000 colours from 16.6 million, scan doubling for flicker free display, 25 MHz, Mouse, Amiga 3.5"/1.76 MB 3.5" drive Plus Cross DOS for transfer of files between Amiga DOS + MS DOS, 2 rear + 2 front 3.5" bays, 1x 5.25" bay, Hard Drive as below, Amiga DOA 3.0 system and utilities, Gold Service Warranty

ALONE	
120MB HD 2 + 4MB	£2259 inc. VAT
120MB HD 2 + 8MB	£2399 inc. VAT
240MB HD 2 + 8MB	£2399 inc. VAT

With Kaga M/Sync SVGA low radiation high-res 28 dot pitch col. monitor inc tilt and swivel, all 4000 modes ADD £400

TRADE IN AVAILABLE

THE HOT LIST
CURRENT TITLES VARY - INCLUDES:

Paperboy II	Hunt for Red October
Colossus Chess	Blinky's Scary School (under 12)
Challenge Golf	Battleships
Neighbours	Licence to Kill - Bond Game
Frankenstein	Silkworm Helicopter jeep mission 93% CU
Edd the Duck (under 12)	Continental Circus - 8 Int race circuits 92% AA
Master Blazer - 3D sports	Xenon - C+VG Game of the Month
Onslaught - Format G 90% Thunderstrike - Fighter Flight Sim	

+ LOTS MORE - AT LEAST 25 TITLES TO CHOOSE FROM!

THE HOTTEST LOT PACK
VALUE/RRP

- All as Starter Pack 203.90
- PLUS:
- Another 10 GREAT individually packaged games, BETTER THAN THE REST previous RRP's up to 39.99 each, phone to choose from HOT LIST, or leave it to us! Children's games available. 269.82
- 80 Prog. Hobbyte PD Greats Pack II - Includes top games like Battlecars, Star Trek, Computer Conflict, Megaball, dozens of arcade classics, board classics and 'shoot-em-ups', DPoint clip art, Utilities, Word Processor, Spreadsheet, Database + Desktop Publisher and the ultimate virus killers - a must for every new Amiga owner! 39.99

TOTAL VALUE 513.71
WITH AMIGA SEPARATELY 49.99
SEPARATELY 69.99
SPECIAL: ALSO 10 extra 'Hot List' games ADD 25.00

NO OTHER DEALER CAN BEAT OUR CREDENTIALS

- 8+ years experience in Commodore product and here to stay
- Commodore trained staff are friendly and helpful and are parents, multimedia, educational, games, programming or technical specialists (usually more than one!)
- Open 9-6 pm Monday to Saturday and 10.00 am to 4.30 pm Sundays for convenient shopping.
- Callers welcome for advice and demonstration at our 1600+ sq ft High St, Town Centre branches
- Same day despatch for most orders received by 5.30 pm; express am and Saturday services available
- Hardware carefully handled and delivered safely and reliably by caged, insured, top name courier service
- Pre-despatch testing on Amiga systems
- Free 30 day, next day courier collection and delivery of NEW replacement (except product with on-site maintenance)
- Hotline support and in-house engineers
- Upgrade and trade in offers to keep you up to date
- Exceptional after sales service
- BFPO and Export welcome

1500 PACK EXTRA (ALSO FOR A500, A500+, A600 CDTV, 3000)
VALUE/RRP

- The Works Platinum, word processor, spreadsheet, database 169.95
- Deluxe Paint III with animation 79.99
- Get the most out of your Amiga book 9.95
- 80 Prog. Hobbyte PD Greats Pack - see 'Hottest Lot Pack' 39.99
- 4 disc 700 Clip Art pics/graphics for DPoint III 9.99
- Puzznic OR Zool 24.99
- Toki Sinker 24.99
- Elf Pimball 29.99
- Digital Home Accounts 29.99

TOTAL VALUE 429.82
WITH AMIGA/CDTV SEPARATELY 49.99
PLUS Starter Pack 67.99

WWW EXTRA - OR 'ANYTHING YOU CAN DO' PACK
VALUE/RRP

- WWW games: Silly Putty 25.99
Formula 1 Grand Prix 25.99
Pushover 25.99
- DPoint III with animation 79.99
- 700 clip art pics/graphics for DPoint III 9.99
- 3 disc Home Pack incl. W Processor, Dbase, Spreadsheet 9.99
- Virus Killer 4.99

TOTAL VALUE 182.93
WITH AMIGA/CDTV SEPARATELY 49.99
SEPARATELY 59.99

ALSO WITH STARTER PACK £18.99 EXTRA

STARTER PACK
MAX VALUE/RRP

- Microswitched Joystick 9.99
- 80 cap. lockable disc box PLUS 10 blank discs 16.98
- 4 great boxed games - See HOT LIST 159.96
- Phone for current choice OR DPoint III + 700 Clip Art Pics/graphics Mouse Mat and Dust Cover 9.98
- 16 Days Free Hotel Accommodation in UK, Ireland or France - you pay only for meals

TOTAL VALUE 196.91
WITH AMIGA/CDTV SEPARATELY 19.99
SEPARATELY 29.99

WITH ANY OTHER PACK ONLY £18.99 EXTRA

EPIC PACK EXTRA
Needs 1MB and Hard Drive VALUE/RRP

- Epic Pack: Trivial Pursuit, Language Lab, Amiga text 29.99
Epic, Rome, Myth 77.97
- DPoint III with animation 79.99
- 700 clip art pics/graphics for DPoint III 9.99
- 3 disc Home Pack incl. W Processor, Dbase, Spreadsheet 9.99
- Virus Killer 4.99

TOTAL VALUE 212.92
WITH AMIGA/CDTV SEPARATELY 39.99
SEPARATELY 49.99

ALSO WITH STARTER PACK £18.99 EXTRA

NOT JUST ANOTHER MAIL ORDER COMPANY
For years a major player in Amiga Mail Order, Hobbyte also boasts extensive expertise and experience in specification and support of multi-machine and specialist systems. Hobbyte have been recommended and trained by Commodore and successfully won major orders and support contracts from London Boroughs, MOD, educational establishments etc. We are pleased to be placed on tender lists.
This expertise is available to all our customers.

PROFESSIONAL FAMILY PACK (1 MB REQUIRED)

	VALUE/RRP
Cartoon Classics Games: Lemmings OR Zool	25.99
The Simpsons Stinker	24.99
Captain Planet Pinball Dream	25.99
Deluxe Paint III with animation + 700 Clip Art pics	89.99
The Works Platinum Word Processor, Spreadsheet and Database	169.99
Edd the Duck	29.99
OR Round the Bend OR Digital Home Accounts	
Virus Killer Disk	4.99
80 Prog. Hobbyte PD Greats Pack - see 'Hottest Lot Pack'	39.99
4 disc DP pack inc. Fonts, Clip Art and Disk Tutor	9.99
Hobbyte Infant, Junior (specify) or Secondary Educational Pack	19.99
10 Blank Discs + 80 Capacity lockable disc box	26.98
Mouse Mat + Dust Cover and Joystick	19.97
TOTAL VALUE	488.85
WITH AMIGA/CDTV SEPARATELY	79.99
	99.99

SPECIAL: Also with Citizen 200 24 PIN Colour Printer and Starter Pack ADD 199.00

ABSOLUTE BEGINNERS PACK 3-13 YEARS

	VALUE/RRP
Your choice from:	
Fun School 2, 3 or 4 (for 3-9 yrs - specify age, 9 diff. versions available) Up to 6 stunning UK educational games in each package, with beautiful pictures, exciting animation + music that helps to develop numbers, word + other skills. Up to 6 levels of difficulty. Conforms with National Curriculum.	25.99
Merlin's Maths (for 7-13 yrs) from the award winning 'Fun School' stable, 6 engaging games to teach essential maths skills, in a way children will love.	
Spelling Fair (for 7-13 yrs) all the fun of the fair on 6 levels makes learning spelling addictive and fun, includes 6 games plus 3000 word dictionary + special selection of words for needs of dyslexic children + parents can create own dictionary of words requiring special attention.	
Edd the Duck (7 yrs) OR EII (7+ yrs) OR Round the Bend	25.99
Hobbyte Infant or Junior (specify) Educational Pack, featuring up to 12 'Learn while you play' games	19.99
Hobbyte 30 Easy Childrens Games, 10 pack disc including Train Set and other top entertaining PD titles	19.99
SpritzPaint + 700 Clip Art pics	89.99
inc. children, Fairytale + Legend characters, Sport, Cartoons etc.	
Joystick + 10 blank discs	15.98
TOTAL VALUE	197.92
WITH AMIGA/CDTV SEPARATELY	39.99
	59.99
SPECIAL: Each extra title from first selection add just	15.00

ALSO WITH STARTER PACK £18.99 EXTRA

TRAMPY'S, THOMAS'S OR NODDY'S PACK 2-8 YEARS

AT LEAST 57 EDUCATIONAL/FUN FILLED GAMES!
MAX VALUE/RRP

The Shoe People - 6 colourful and entertaining games featuring Trampy and friends to encourage early number reading and pre-reading skills. With Shoe People music	29.99
OR Thomas the Tank Engine's Fun with Words - 6 separate easy to use learning programmes with animation and sound.	
OR Noddy's Playtime (to 7 years) - 8 magical learning games at 3 levels, PLUS Junior Art package inc. Colouring, electronic 'Fuzzy Felt', FREE Toy Town map, Keyboard overlay and wobbler.	24.99
Shapes and Colours - Bobby the Clown entertains and lays down the foundation for maths and writing in 6 colourful animated games.	9.99
Fun School 2, 3 or 4 - the 'Fun School' suite have won just about every award going. 5 or 6 wonderful animated games.	24.99
OR Picture Book: 4 colourful and amusing games from ex 'Fun School' design manager will delight young children.	
SpritzPaint + 700 Clip Art pics inc. children, Fairytale + Legend characters, Sport, Cartoons,	89.99
Hobbyte Infant Educational PD Pack, containing 10 fun while you learn games	19.99
Hobbyte 30 Easy Childrens Games Pack	19.99
10 Blank Discs, Joystick, Mouse Mat	26.96
TOTAL VALUE	221.90
WITH AMIGA/CDTV SEPARATELY	59.99
	79.99
SPECIAL: Each extra title from first selection add just	18.99

ALSO WITH STARTER PACK £18.99 EXTRA

LIMITED ZOO GCSE 11-15 YEARS

+ SCHOOL PACK

Zool - Number 1 Chartbuster	25.99
Striker - 94% CU Amiga	25.99
Pinball Dreams - 94% AUI	25.99
Transwrite UK WP + Spellchecker	49.99
ADI French, Maths or English (11-15, specify age)	
ADI the lovable extra terrestrial gifted teacher, guides you through National Curriculum. Ideally compliments school work. From the award winning Fun School team	25.99
OR	
6 HOT LIST Games	209.94
Hobbyte 80 Programme PD Greats Pack - See 'Hottest Lot'	39.99
Hobbyte Secondary Educational Pack	19.99
Microswitched quality joystick	9.99
TOTAL VALUE	407.87
WITH AMIGA/CDTV SEPARATELY	49.99
	69.99

ALSO WITH STARTER PACK £18.99 EXTRA

AMIGA 24 BIT SYSTEM - £BEST! WE SPECIALISE

- Extra RAM • Accelerator
- 24 bit colour card • 24 bit colour real time digitizer
- 24 bit 3D Art + animation s/w
- Fitting and Free 1/2 day customised training

TELEPHONE JP

THUNDERBIRDS ARE GO!

We hope! We are trying to organise a pack, complete with die-cast toy, no promises, but phone for latests!!

ACCESSORIES

Blitz virus protector + backup	23.99	Golden Image Happy Mouse	18.99
A520 Modulator	29.99	GI Brush Mouse + DPIII	23.99
A500 Deluxe control centre	44.99	GI Optical Mouse	28.99
A600 Central Centre	29.90	GI Crystal Trackball	35.99
CDTV Keyboard	39.99		

MODEMS

Amstrad SM 2400 Modem	118.99
Supra Fax 2400 + 5 year warranty	78.95
Supra Fax 2400 Plus + 5 year warranty	137.95

FLOPPY DRIVES

Zydec 3.5 external drive, daisychain + on/off	48.95
Cumano CAX 354 3.5 external drive, beige	52.99
CDTV external 3.5 drive, black + 10 blank discs	49.99
PC 880B with anti click + Blitz back up and virus protector	65.00
PC 880B as above, Cyclone compatible	78.99
Dual drive as PC 880B	125.00
Replacement A500 drive	34.95

MONITORS/ACCESSORIES

CBM 1084ST including tilt + swivel + 2 games	199.95
CBM 1084SDI monitor + leads + 2 great 'Hot List' games	189.00
Philips UK 8833 MKII mon. + leads + Turbo Challenge + on-site	219.99
Tilt + swivel stand for Philips 8833	12.99
CBM 1960 High res monitor	399.99
Philips 7CM Hi-res SVGA 28dp inc. tilt + swivel	259.99
NEC 4FG Multi-Sync	544.99
Microcopy Flicker Fixer	124.99
ICD Flicker Free Video 2-A500	197.90
Elec. Des Fix	196.99
KAGA 14" Multi Sync for 1200/4000	429.00
KAGA 20" Multi Sync for 1200/4000	1549.00

SCANNERS & DIGITISERS

Epson GT 6000, 600dpi 24 bit A4	789.00
Epson GT 8000, 800dpi 24 bit A4	1192.99
Power Hand Scanner, 400 dpi, 64 Greyscale, Powerscan software	88.99
Power Colour Hand Scanner	219.49
Sharp JX 100 A6 Scanner + scanlab s/w up to 18 bit	469.99
Sharp JX 370A6 Scanner + s/w up to 24 bit	898.99
Vidi Amiga 12	73.99
Summa Sketch II A4 Tablet Digitiser	319.99
Summa Sketch II A3 Tablet Digitiser	529.99

GENLOCKS

CBM Rendale 8802/8806	POA	Roggen Plus	114.49
CBM Rendale 8802 SVHS	529.99	Progen	85.99
Roggen	78.95	Video Plot v330	994.94
Elec. Des Pal Genlock	329.99	Elec. Des YC Genlock	496.49

DISCS

10 Blank DS/DD discs in box	4.99	50 Blank DS/DD discs	17.99
10 Blank DS/HD discs	6.99	50 Blank DS/HD discs	27.99

ACCELERATORS/HDA500/600

A530 1MB 120MB	728.99	20MB HD upgrade	119.00
A530 1MB 240MB	908.99	40MB HD upgrade	199.00
A530 68882	203.99	60MB HD upgrade	225.00
GVP HD8 42MB	339.99	80MB HD upgrade	275.00
GVP HD8 85MB	439.99	IVS Trumppcard 42MB HD	279.99
GVP HD8 120MB	499.99	Extra 2MB fitted to any above	62.99
A590 20MB	259.99	Microbotics VXL30 25MHz	219.99
A570 for 2.04 1MB 500	309.99	2MB Burst RAM for above	179.99

ACCELERATORS/HD A1500/2000/3000

GVP Series II 40MB	309.99	G Force 030 50MHz 4MB	1099.99
GVP Series II 80MB	379.99	G Force 040 33MHz 2MB	POA
GVP Series II 120MB	409.99	Prog.Zeus 040 20MHz 4MB	1739.99
GVP Series II 420MB	1033.99	Prog.Maryu 040 20MHz (3000)	1349.99
G Force 030 25MHz 1MB	543.99	Sysquest removable HD 88MB	549.95
G Force 030 40MHz 4MB	783.99	Extra 2MB fitted to any above	62.99

EXPANSION

A500 512k Ram Exp+Clock	19.90	A1200 32 bit 2MB exp	POA
A500 + 1MB exp	28.99	A1200 32 bit 4MB + 68881	279.00
A500 + Switch 1MB exp	37.99	A1200 32 bit 4MB + 68882	349.00
CBM 2.04 upgrade kit	74.99	A1200 32 bit 8MB + 68882	549.00
A600 1MB exp (chip)	39.99	A500 Rom Sharer 1.3	POA
A600/1200 2MB exp (fast)	117.99	A500 Rom Sharer 2.04	POA
A600/1200 4MB exp (fast)	179.99	A600 Rom Sh. + 1.3	POA

Chip fitting and board upgrade available, by our qualified engineers or DIY kit

EMULATION

KCS Powerboard	POA	G Gate 386sx 25MHz	438.99
KCS Powerboard with DOS	POA	G Gate 486SX	795.99
KCS adaptor	POA	GVP 286 for GVP II + 530	216.99
AT Bridgeboard for 1500	299.00	AT Once	214.99
386 Bridgeboard for 1500	POA	GVP 40/4 for 1500	945.99

2YR WARRANTY PRINTERS WITH CITIZEN

ALONE	WITH STARTER PACK	ALONE	WITH STARTER PACK
Citizen 120 + D	110.99	Citizen S240 24 col	259.99
Star LC20	113.49	Citizen S24x col	296.99
Star LC 100 9 pin col	146.49	HP Deskjet 500	329.99
Star LC200 col	163.49	HP Deskjet col ³	399.99
Citizen Swift 9"	163.49	HP Deskjet 550C	519.99
Star LC 24-20	173.49	HP Paintjet ³	639.99
Star LC 24-100 24 pin	163.49	BJI/Ox Bubblejet port.	204.99
Star LC 24-200	197.25	BJ 20	304.99
Star LC 24-200 col	236.49	BJ 330 A3	469.99
Citizen 1240	176.99	BJ 300	338.99
Epson LQ 100	189.99	Star SJ 48	191.49
Citizen S200 24"	179.99	HP Laserjet 11P +	649.99
Citizen S200 24 col	189.99	QMS Ink Jet col A4	4999.95

3 Turbo Print Pro driver/util s/w highly recommended ADD £39.95

STARTER PACK: 500 Sheets A4 or continuous paper, Amiga to printer lead, Universal Printer Stand & Driver with Print Manager

24 BIT

A Video 24 with TV Paint for 500	588.90	Harlequin 4000 24 bit card	1289.99
Art Dept. Pro 2.1A	129.99	Image Master	1069.00
DCTV	403.99	Opal Vision 24 bit board + Opal Paint, Opal Firecracker	POA
GVP IV + VII-S	1389.99	Presents, Karate 24 bit s/w	659.00
GVP IV + VII-CT	1759.99	Rembrandt 24 bit board	2489.99
		V lab 24 bit real time digitiser	279.99

SOFTWARE

GRAPHICS/CAD		Pro Video Plus	137.99	Kind Words III	35.99
AmigaVision	47.50	TV Show Pro	51.39	Maxiplan Plus v4	35.99
Deluxe Paint IV	53.99	TV Text Pro	68.99	Mini Office	43.99
Expert 4D Junior	36.99	Video Director	106.99	Pogestream 2.2	143.99
Expert Draw	48.99	EDUCATIONAL		Pogesetter II	42.49
Imagine v2	109.49	Any Fun School	14.99	Pen Pal 1.4	52.50
Real 3D Beg 1.4	83.99	Any ADI	17.50	Personal Finance Manager Plus	31.99
Real 3D Turbo Pro 1.4	229.50	See also software packs		Pro. Page v3	137.99
Scala 500	68.99	UTILITIES/LANGUAGES		Saxon Publisher	177.95
Scala MM200	434.99	AMAX II Plus	249.99	Superbase Pro 4	148.99
Scala Pro 1.13	173.50	Amos 3D	21.49	Wordsworth V2	79.99
Sculpt		Amos the Creator	30.95	Works Platinum	43.99
Animate 4D	198.99	Amos Compiler	19.49	MUSIC	
Spectra Colour	57.99	Easy Amos	22.49	AD 10 12 Studio 16 Sampler	349.95
X CAD 2000	89.50	Amos v5	22.75	Audio Engineer Plus 2 Sampler	188.99
X CAD 3000	205.99	Essence	43.75	Audio Master 4	44.49
Alodin 4D	213.99	GFA Basic	17.99	Bars & Pipes Pro 1.0E	162.99
VIDEO PRODUCTION/TITLING		Latrice C 6	219.99	GVP Digital Sound Studio	48.99
Adorage	59.49	Quarter back	30.50	Midi Interface	19.95
AmigaVision	47.50	Quarter back Tools	44.99	Romba Megamix	23.99
Broadcast		Xcopy Pro	44.95		
Titler II	148.99	APPLICATION			
Deluxe Photolab	51.49	Arena Accounts	89.50		
Morph+	134.99	Excellence 3	88.99		
		Final Copy II	66.99		

ORDERING:

TELESALES NO: (0727) 56005

Next day delivery for credit card orders placed before 5pm subject to availability. Alternatively send cheque, postal order, bankers draft or official order (PLCs, Education and Government bodies only) to: Dept. AE, Hobbyte Computer Centre, 10 Market Place, St. Albans, Herts AL3 5DG. Please allow 7 working days for cheque clearance. Subject to availability, despatch is normally within 24 hours of receipt of cleared payment. Prices are correct at time of going to press, however, we are sometimes forced to change them, either up or down. Please check before ordering. Additional services and different packages may be offered in our showrooms, and prices may vary from Mail Order prices. Personal callers are asked to quote this ad to ensure Mail Order packages are offered.

DELIVERABLES

Small consumables & software items
Other items, except lasers
Offshore and Highlands
In addition we offer the following EXPRESS SERVICES:
Saturday deliveries
Arr next day

UK MAINLAND (NOT HIGHLANDS)

Despatched by post, please check charges when ordering
Next day courier service, £10 per box
Please enquire
Normal rate plus £15 + VAT per box
Normal rate plus £8 + VAT per box

NO DEPOSIT CREDIT FACILITIES

Credit terms at 34.8% APR (variable) can be arranged for purchases over £150, subject to status. Competitive leasing schemes are also available for businesses, including sole traders and partnerships. Just telephone for written details and application form.

Amiga prices, except where stated are inc. VAT. E.&O.I.

• HP AUTHORISED DEALER • CITIZEN DEALER PLUS •

TELE-ORDER (0727) 56005

NOTE see warning across



If you want to create your own hip-hop, dance or rave music, but you don't think you have the talent, **Andy Nuttall** may have just the thing...

music, and add in effects such as pitch shift, echo and repeated loops.

The Jam screen is similar to Remix, except that here you can change the current pattern by clicking on one of the style buttons at the bottom of the screen. Four different drum styles are provided for each backbeat, along with four bass and four melody lines. If these are selected during recording, the new pattern will play at the start of the next bar. Using this method you can change the feel of the music as it plays, creating an entire song easily and quickly.

The main *Boom Box* screen, which is used to play the pre-recorded tracks and adjust each volume using the sliders.

Boom Box achieves its objectives because it enables you to begin playing and mixing as soon as you load it up, and it's simple and great fun to use. It does have some limitations, however, which could have been made better.

The main niggle is that you can't create your own patterns of music, so you're stuck with the patterns provided. Of course, it doesn't claim to be a sequencer, so it would be unfair of us to mark it down because of this, but some kind of pattern-creating routines wouldn't have gone amiss. Having said that, there are enough patterns built-in to keep you going for a while – and there is scope for add-on disks in the future should this package prove to be popular.

The other minor point is that the timing will occasionally go awry when you try to jam along with too many samples. This is a bad point, but it shouldn't happen too often.

This is an excellent introduction to making computer music, as control is easy and it's not at all technical. Any parents who have kids that are into hip-hop, techno or rave music could do worse than buy them this package. OK, maybe it won't teach them to play the piano, and they won't use it to make a hit record, but they might find it a useful stepping stone to greater things.

Boom Box

£39.95 ■ Music software ■ Dr T's

WHETHER YOU ALREADY own an Amiga or not, it's likely that you already know about its musical power. Not only is it becoming the choice of MIDI musicians everywhere, it also has the capability of playing samples without any external hardware.

It is this latter point that Dr T's have exploited with their latest program, *Boom Box*. The developers, who are already renowned for their excellent MIDI sequencer *KCS 3.5* and patch editor *X-oR*, are aiming their new product at a market full of would-be musicians who have no previous experience with computer music, but have got an Amiga and they know it's capable of making a decent noise.

The idea is that *Boom Box* just provides a backbeat while you alter the mix of the music and simply have a jam by using internal Amiga samples. You are provided with seven different backbeats, each with differing musical styles such as hip-hop and rave. Each one consists of three separate tracks for drums,

bass and melody, while a fourth track is left open so you can play the samples over the top.

Boom Box is controlled via one of three different function screens, Playback, Remix and Jam. The Playback screen acts in a similar way to a ghetto-blaster style tape player, with controls such as play, pause, fast-forward and rewind. Here you can also adjust the volume level of each track separately to set the 'feel' of the piece of music you're trying to create.

The Remix screen enables you to alter the mix of a backbeat, by using your mouse to move the volume sliders corresponding to each of the four tracks. At the same time, pressing keys 1 to 6 triggers an IFF (internal) sample stored in memory.

The six can be chosen from the 50 different which are provided, or if you own a sampler you may use your own. The samples included are pretty varied – from hip-hop style drum machines to the obligatory James Brown vocals. You can also alter the tempo of the

BOOM BOX is available from **Zone Distribution** 071-733 8444



The Jam screen, where you can remix the tracks, changing the bassline, rhythm and top end, while jamming along using the samples provided.

Boom Box

SPEED ●●●
Generally quick and responsive, but it can occasionally slip out of time.

DOCUMENTATION ●●●
A reasonable manual containing both Amiga and PC instructions – but only PC screenshots.

ACCESSIBILITY ●●●●
Very easy to get into, clearly presented and great fun to use.

FEATURES ●●●●
The patterns and samples provided are good, and the options are well thought-out.

VALUE ●●●●
An excellent package, well worth getting for hip-hop fans, but marginally overpriced.

Verdict **80%**

AMIGA SUPER VALUE PACKS

A600FD STANDARD FEATURES

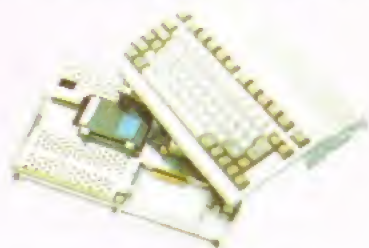

- ★ ON SITE MAINTENANCE
- ★ 1 MB RAM
- ★ 1 MB DISK DRIVE
- ★ BUILT IN TV MODULATOR
- ★ 4096 COLOURS
- ★ SPEECH SYNTHESIS
- ★ MULTI-TASKING
- ★ 4 CHANNEL DIGITAL STEREO SOUND
- ★ MOUSE
- ★ WORKBENCH DISKS
- ★ COMPREHENSIVE MANUALS
- ★ ALL CONNECTING CABLES

WANT 2MEG OF RAM?

UPGRADE YOUR A600 TO A MASSIVE 2MB OF RAM FOR ONLY

£39.95

WHEN YOU ORDER YOUR A600
(Normal RRP £59.95)

WANT AN A500 PLUS V.2?

LOOK AT PAGE 3
UNDER SPECIAL PURCHASE

A600FD BAD INFLUENCE PACK

A600FD COMPUTER AS PER STANDARD SPECIFICATION

PLUS ASTRA TEN GAME PACK	PLUS BAD INFLUENCE GAMES	PLUS ACCESSORY PACK
Datastorm.....19.95	WWF WRESTLING ..£29.99	2 MICROSWITCH JOYSTICKS ..£25.98
Dungeon Quest.....19.95	A must for wrestlemania fans	Not one but two quality joysticks
E-Motion19.95	FINAL FIGHT£29.99	TAILOR MADE DUSTCOVER ..£12.99
Grand Monster Sam ...19.95	Arcade martial arts at its best!	Essential protection
RVF Honda24.95	PITFIGHTER.....£29.99	HIGH QUALITY MOUSEPAD ..£7.99
Driving Force24.99	Ringside fighting action	Keeps your mouse squeaky clean
Pipemania24.99	<i>This super value pack</i>	
Rock 'n' Roll19.99	<i>retails for over £650, but</i>	
Skweek19.99	<i>is available to you for only</i>	
Tower Of Babel.....19.99		

£299.99

A600FD GAMESMASTER PACK

Incorporating Commodore 'THE WILD, THE WEIRD AND THE WICKED' A600FD COMPUTER PLUS ALL ITEMS LISTED IN 'BAD INFLUENCE' PACK

PLUS WILD, WEIRD & WICKED	PLUS SPORTSTARS PACK	PLUS BASIC PACK
DELUXE PAINT III.....£49.99	KICK OFF.....£29.99	GFA BASIC£49.99
Essential painting package	The original and greatest football game	Essential for Basic programming
GRAND PRIX£34.99	PRO TENNIS TOUR ..£29.99	PRECISION DISKS.....£12.99
The best racing simulation ever!	Stunning gameplay & effects	Ten branded disks to get you going
PUSHOVER£29.99	GFL GOLF£29.99	40 CAPACITY DISK BOX.....£9.99
Infuriatingly addictive puzzle game	Play a round in the comfort of home	Essential for storage
PUTTY.....£29.99	<i>This super value pack</i>	
Brand new release from System3	<i>retails for over £950, but</i>	
	<i>is available to you for only</i>	

£349.99

A600HD EPIC/LANGUAGE LAB PACK

A600HD as standard with 20Mb Hard Disk built in PLUS ALL ITEMS LISTED IN 'BAD INFLUENCE' PACK

PLUS EPIC/LANGUAGE PACK	PLUS BASIC PACK	PLUS PAINT PACK
TRIVIAL PURSUIT...£39.99	GFA BASIC£49.99	PHOTON PAINT 2 ...£89.95
Super 3 language version	Essential for Basic programming	One of the most
EPIC.....£29.99	PRECISION DISKS.....£12.99	comprehensive paint
Space shoot-em-up	Ten branded blank disks	packages on the market.
ROME.....£29.99	40 CAPACITY DISK BOX ..£9.99	
Millenium classic	Essential for storage	
MYTH£29.99	<i>This super value pack retails</i>	
Arcade adventure	<i>for over £1140, but is avail-</i>	
	<i>able to you for only</i>	

£499.99



ORDERING MADE EASY



BY PHONE



Simply call our Head Office quoting your Access/Visa number on **0234 218060 (5 lines)**
Open 9.00am - 8.00pm



BY CALLING PERSONALLY

Simply call in to your nearest FutureWorld store where our fully trained personnel will be more than happy to deal with your requirements.

BY POST

Make cheques, Building Society drafts or Postal Orders payable to



FUTUREWORLD COMPUTERS LTD,
UNITS 25-27 SERGEANTS WAY
ELMS INDUSTRIAL ESTATE BEDFORD
MK41 0EH

Please write cheque guarantee card number on the reverse of cheque to ensure same day clearance. Cheques without a card number subject to 10 days clearance.



REMEMBER ALL PRICES ARE INCLUSIVE OF VAT & COURIER DELIVERY (UK Mainland only) SATURDAY DELIVERY £10.00

FINANCE

Finance available to suit your specific needs. Written details on request. Instant credit is available in all FutureWorld stores.

PREMIER GOLD CARD

- 7 day money back guarantee on goods purchased if not completely satisfied (subject to goods being returned in mint condition)
- 30 day exchange for new policy should a fault occur
- 1 year guarantee giving free collection and delivery service should a fault occur.
- Exclusive Premier Gold Card with Personal Membership Number entitling you to special offers
- All this for only £19.95 per item purchased

1 YEAR GUARANTEE

For the whole guarantee period, warranty service will be completely free of charge

TECHNICAL SUPPORT/ON SITE ENGINEERS

Being authorised service centres for AMSTRAD, COMMODORE & STAR, we are equipped to deal with the majority of queries. Lines open 3.00pm to 5.30pm

FULLY COMPUTERISED ORDERING SYSTEM

This enables our telesales staff to provide up-to-the-minute stock information coupled with efficient dispatch.

FULL TESTING PROCEDURE

All computer hardware is tested prior to dispatch maintaining our motto:

Simply the
BEST

All goods subject to availability
All prices correct at time of going to press.

E & OE

SALE STAR SALE PRINTERS

All our Star Printers now come with the following value pack worth £34.96 COMPLETELY FREE

QUALITY COMPUTER CABLE.....RRP £9.99
UNIVERSAL PRINTER STAND.....RRP £9.99
200 SHEETS CONTINUOUS PAPER.....RRP £4.99
TAILOR MADE DUST COVER.....RRP £9.99
16 NIGHTS HOLIDAY ACCOMMODATION
● PLUS ● PD DISK PACK CONTAINING

Wordprocessor ● Spreadsheet ● Database ●
Virus Killers ● Backup Utility

STAR LC20 MONO PRINTER

9 Pin Dot Matrix 180/45 cps
TOTAL RRP with value pack £268.01

But yours for an unbelievable **£139.95**

NEW STAR LC100 COLOUR PRINTER

9 Pin colour, 180/45 cps
TOTAL RRP with value pack £299.95

But yours for an unbelievable **£179.95**

STAR LC200 COLOUR PRINTER

9 Pin colour 185/45 cps
TOTAL RRP with value pack £339.95

But yours for an unbelievable **£199.95**

STAR LC24-200 MONO PRINTER

24 Pin mono printer 220/55 cps
TOTAL RRP with value pack £386.29

But yours for an unbelievable **£239.95**

NEW STAR LC24-100 MONO PRINTER

24 Pin mono, 192/64 cps
TOTAL RRP with value pack £349.95

But yours for an unbelievable **£189.95**

STAR LC24-200 COLOUR PRINTER

24 Pin colour printer, 220/55 cps
TOTAL RRP with value pack £445.04

But yours for an unbelievable **£289.95**

STAR SJ48 INKJET PRINTER

High speed/quality mono printer. 100cps (LG)
TOTAL RRP with value pack £379.96

But yours for an unbelievable **£234.95**

"VOTED NO1
RETAILER
OF 1992"

AMIGA 1500 CARTOON CLASSICS SUPERPACK

NEW AMIGA 1500 featuring Workbench/Kickstart 2. The Works. D Paint III. Home Accts etc.....RRP £699.95
ASTRA TEN GAME PACK 10 individually packed games (see A500 GameMaster pack for details).....RRP £229
GFA BASIC Essential for basic programming RRP £49.99

CARTOON CLASSICS SOFTWARE

Bart Simpson Vs Space Mutants "Lemmings" RRP £79.97
Captain Planet RRP £15.98
2 FIGHTER JOYSTICKS RRP £6.99
QUALITY MOUSEPAD RRP £6.99

TOTAL RRP £1082.62

But yours for an unbelievable
£599.95

N.B This Machine requires a TV/Modulator (£24.95) if it is to be used with a television

"VOTED NO1
RETAILER
OF 1992"

STEREO COLOUR MONITOR

Exclusive to FutureWorld

PHILIPS 8833 MKII
LOTUS/F19 PACK

Features:

- ★ Award winning stereo monitor
- ★ On-site maintenance
- ★ LOTUS TURBO CHALLENGE 2 PLUS
- ★ F19 STEALTH FIGHTER

**ONLY
£199.99**

"VOTED NO1
RETAILER
OF 1992"

MEMORY DRIVES & SCANNERS

MEMORY

512K RAM EXPANSION WITHOUT CLOCK £19.95
WITH CLOCK £24.95

1.5 MEG EXPANSION (Not Plus compatible) £79.95

1 MEG EXPANSION (Gives your A500 plus a massive 2MB) £39.95

1 MEG EXPANSION WITH THRU-PORT £49.95

NEW 8 MEG RAM BOARDS FROM POWER

Complete with Thru-Port Populated board with 0 Meg RAM £99 ●
2 Meg RAM £129 ● 4 Meg RAM £189.95 ● 8 Meg RAM £299.95

DRIVES

DIRECT A500 REPLACEMENT DRIVE with instructions £44.95

POWER PC880B Robust slim drive with anti-click £49.95

CUMANA CAX 354 SLIMLINE DRIVE £54.95

POWER PC 880B with Blitz/Virus hardware £69.95

POWER PC880B + X-COPY PROFESSIONAL £99.95

DUAL POWER PC880B complete with Power supply £124.95

HARD DRIVES

GVP 52 MEG HARD DRIVE WITH RAM EXPANDABLE TO 8MB. 0 Meg RAM £379.95 ● 2 Meg RAM £429.95
● 4 Meg RAM £499.95 ● 8 Meg RAM £679.95

GVP 105 MEG HARD DRIVE WITH RAM EXPANDABLE TO 8MB
● 0 Meg RAM £579.95 ● 2 Meg RAM £629.95 ● 4 Meg RAM
£729.95 ● 8 Meg RAM £899.95

POWER SCANNER WITH VERSION 3.0 SOFTWARE £99.95

UPGRADE KIT FOR NON POWER SCANNER UNITS
Complete with hardware interface and new version
3.0 software £49.95

FutureWorld
computers



**WORDWORTH
v1.1 SCOOP
AT £29.95★
★ With any
purchase
over £50**

**SAVE
£100**

Simply call in one of our stores or ring our telesales department. Make any purchase to the value of £50 or more and we'll supply you with the **BEST** Amiga wordprocessing package on the market for just **£29.95** - saving you £100! But hurry stocks are limited at this crazy price! Alternatively you can buy Wordworth v1.1 on its own for **£69.95**

**"VOTED NO1
RETAILER
OF 1992"**

**★★ SPECIAL PURCHASE ★★
A500 PLUS VERS 2.0
CARTOON CLASSIC PACKS**

**FEATURING:
DELUXE PAINT III
BART SIMPSON
CAPTAIN PLANET
LEMMINGS**

RRP £399

SUPER LOW PRICE

£299.99

★★ SPECIAL PURCHASE ★★

**TOP TEN CHRISTMAS
GIFT IDEAS AT GIVE-
AWAY PRICES WHEN
YOU SPEND OVER £25 IN
ANY OF OUR STORES OR PUR-
CHASE MAIL ORDER ★**

ITEM	NORMAL PRICE	GIFT PRICE
1 40 Capacity 3.5" Lockable Disk Box	£9.99	£2.99
2 80 Capacity 3.5" Lockable Disk Box	£14.99	£4.99
3 Pack of Ten Branded Precision 3.5" Disks	£12.99	£3.99
4 3.5" Disk Drive Cleaner Kit	£9.99	£1.99
5 High Quality Semi-soft mousepad	£7.99	£1.49
6 200 Sheets of Continuous Printer Paper	£7.99	£1.99
7 Standard Microswitch Joystick	£9.99	£3.99
8 Zipstick Superpro Autofire Joystick	£16.99	£8.99
9 Quickjoy Topstar Joystick-The Ultimate	£23.95	£14.99
10 Replacement Amiga Mouse	£24.95	£9.99

**★ LIMITED TO ONE GIFT
PER TRANSACTION**

PROFESSIONAL AMIGA REPAIRS

"Simply the Best" Commodore authorised repair centre
FREE COLLECTION & DELIVERY BY COURIER Make one simple phone call and leave the rest to us!
GUARANTEED 7 DAY TURN AROUND We guarantee to return your computer **WITHIN 7** days of collection
FULL OVERHAUL INCLUDING OVER 50 DIAGNOSTIC CHECKS Your Amiga will look as good as new
3 MONTH COMPREHENSIVE GUARANTEE Our engineers work to the highest standard
ALL INCLUSIVE PRICE We won't con you with hidden extras
FREE 50 GAMES SOFTWARE PACK

For a limited offer we will give you a 50 games pack completely free!

**ALL FOR THE INCREDIBLE
PRICE OF £59.95**

NB Personal callers in to one of our stores may deduct £10 from the above price. We reserve the right to refuse computers that have been tampered with or are beyond economical repair. In this instance a nominal £10 charge will be made to cover carriage costs.

EXTEND YOUR WARRANTY TO A TOTAL OF 1 YEAR FOR ONLY AN ADDITIONAL £20.00

ALL PRICES INCLUDE VAT & COURIER DELIVERY

**VISIT YOUR
LOCAL STORE**

BASILDON MEGASTORE

12/13 South Walk, Basildon
Telephone (0268) 270013

BEDFORD MEGASTORE

1 The Howard Centre, Bedford.
Telephone (0234) 212460

LUTON SUPERSTORE

3 Arndale Centre, Luton
Telephone (0582) 482680

NORTHAMPTON SUPERSTORE

1-7 College St, Northampton
Telephone (0604) 33996

ST. ALBANS SUPERSTORE

34 Market Place, St. Albans
Telephone - Call Head Office

WELWYN GARDEN CITY

16 Church Road, W.G.C.
Telephone (0707) 390029

**OPENING SOON
MEGASTORES**

ALDERSHOT

WEMBLEY

SUPERSTORES

BARNET

WALTHAMSTOW

**"VOTED NO1
RETAILER
OF 1992"**



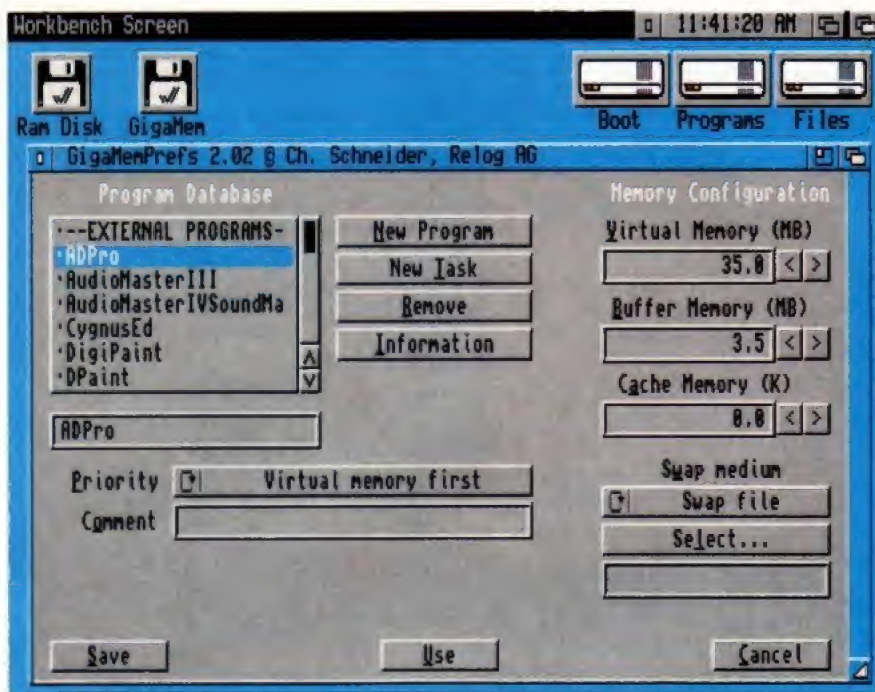

Jason Holborn examines a program that claims to add hundreds of gigabytes of memory to your Amiga...

GIGAMEM is available from **HB Marketing** 0753 686000

The *GigaMem* Preferences program gives you extensive control over your 'virtual memory' – a clever technique that enables your hard drive to pretend it's actually RAM.

performed faultlessly while it has been installed on my A3000.

With all that virtual RAM at your disposal, it's now perfectly possible to run several large tasks concurrently. You could, for example, run a hand scanner at 400 dpi, process 24-bit graphics in *Art Department Professional*, digitise sound at 52KHz and build up a minute-long animation within *DPaint*, all without running out of memory. In practice this isn't always the case though.

What you must consider is that virtual RAM is treated as fast RAM, so any program that relies solely on chip RAM will not be able to take advantage of *GigaMem*. Thankfully most modern graphics and music programs are not held back by the chip RAM limitation, so you'll probably only encounter this problem with older programs.

GigaMem most certainly isn't the answer to every Amiga owner's RAM-shortage problems. Most of us encounter these problems sooner or later, but *GigaMem* won't be of use to you unless you're lucky enough to own a machine that is capable of handling it. Thankfully the price of processor cards equipped with memory-management units is starting to fall dramatically (especially now that Commodore have released the A1200 and dropped the price on the A3000), so the sort of hardware that is required to run *GigaMem* is no longer the sort of pie-in-the-sky stuff that it was two years ago.

If you have got a machine that is capable of running *GigaMem* and you've got plenty of space available on your hard drive, then *GigaMem* may well be the answer to all your RAM shortage problems. Although software solutions such as this will never really perform as well as a dedicated RAM expansion, *GigaMem* represents a very good alternative. One thing's for sure – *GigaMem* will definitely be staying on my hard drive.

GigaMem

ETBA ■ Virtual memory software ■ HB Marketing

BACK IN THE days when 8-bit micros roamed the Earth, the memory capacity of your microcomputer was often measured in terms of kilobytes rather than megabytes. Back then, most of us were more used to 64K, 48K or even measly 32K micros – a machine with anything more than this was considered to be a real powerhouse!

In these days of 24-bit graphics and 16-bit sound sampling, though, a machine with less than 2Mb of RAM is considered almost unusable! I'm lucky enough to own a machine equipped with a full 9Mb of RAM, but even this elephant-like memory capacity is often not enough for sophisticated applications.

So what do you do when memory problems start to occur? The obvious answer would be to add more memory to your system in the form of RAM chips. This is all well and good providing that you have both an accelerated Amiga that is capable of being expanded beyond the Amiga's self-imposed 10 Mb memory limit and your pocket can take the strain (32-bit RAM chips don't come cheap).

Believe it or not though, there is a way of getting around this problem without having to dish out megabucks – all you need is a hard disk, an accelerated Amiga equipped with an MMU (Memory Management Unit) and a copy of *GigaMem*, the Amiga's first virtual-memory system.

Virtual memory is a very clever software technique that attempts to fool your Amiga into thinking that it has more memory than is actually installed inside your machine. The data which the Amiga attempts to store in this

'fake' memory is in fact held on your hard disk. Using some very clever buffering, data is transported to and from the hard disk whenever it is needed by the application that created that data. Although this obviously results in a slow-down in the system performance, it's a small price to pay for all those extra megabytes of memory.

The amount of virtual RAM that you can access is limited only by the capacity of your hard disk, although it's unlikely you'll ever need more than a 100 Mb. *GigaMem* is capable of handling up to one gigabyte of virtual RAM (that's 1,024 Mb!) so it's very unlikely that you'll ever feel held back.

Like most virtual memory systems, *GigaMem* won't work unless you own a fairly powerful computer. Even if you own a machine equipped with a processor accelerator, *GigaMem* won't run unless the card is equipped with a memory management unit (MMU). Both the 68030 and the '040 have these built in as standard, so A3000 and A4000 owners have nothing to worry about.

Another very important addition is a pretty substantial (and fast) hard disk. Unlike programs of this kind on other systems, *GigaMem* doesn't insist that you set aside a partition of your hard drive for the virtual RAM, so there's no need to reformat your existing drive. Personally, though, I would recommend such a practice simply because it offers far more security just in case something does go wrong – losing the contents of your virtual RAM won't be too much of a loss, but you'll kick yourself if your hard drive gets wiped! To be fair though, *GigaMem* has

GigaMem

SPEED ●●●●

Considering the complexities of virtual memory, it has very acceptable performance figures.

DOCUMENTATION ●●

The *GigaMem* manual could probably benefit from some more in-depth explanations.

ACCESSIBILITY ●

How many Amiga users own an accelerated Amiga with a memory-management unit?

FEATURES ●●●●

For what should be a minimal price, *GigaMem* can add a Gigabyte of RAM to your system.

VALUE ●●●

Considering the high cost of RAM chips, *GigaMem* offers a very good alternative.

78%

CITIZEN

PRINTERS

WITH
2 YEAR WARRANTY

NEW MODELS

AND
LOWER PRICES

FREE! STARTER KIT

ALL YOU NEED TO GET STARTED WITH YOUR NEW CITIZEN PRINTER

- 2 Metre Parallel Printer Cable
- 3 1/2" Disk - Driver for Windows 3.1
- 3 1/2" Disk - Amiga & ST Drivers
- 200 Sheets of Continuous Paper
- 100 Continuous Address Labels
- 5 Continuous Envelopes

WORTH £29.38

WITH EVERY
CITIZEN DOT MATRIX PRINTER FROM SILICA or £19.38 (£10 off RRP) to purchase.

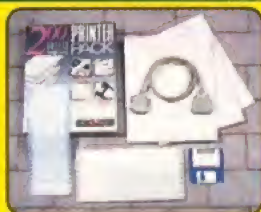

PLUS! FREE AMIGA PRINT MANAGER V2.0
For faster printing from your Amiga, with clearer images and more vibrant colours. Available free of charge (on request) when you buy a Swift 9x, 24x, 200 or 240 printer.

Features include:
• Improved Image Smoothing
• Gamma/Colour Correction
• Image Scaling
• Colour Separation
• Reduces/Minimises Banding (inc VAT - see text) V2.0 or for £12 - VAT + £14.10 to purchase (ASC 167)

WORTH
£14.10

BUDGET 9 PIN PRINTER

144 CPS 80 COLUMN

- Citizen 120D+ - 9 pin
- 144cps Draft, 30cps NLO
- 4K Printer Buffer + 2 Fonts
- Parallel or Serial Interface
- Graphics Resolution: 240 x 240dpi
- Epson and IBM Emulation
- Pull tractor & bottom feed
- FREE Silica Printer Starter Kit

RRP £199
SILICA STARTER KIT £25
TOTAL VALUE: £224
SAVING: £109
SILICA PRICE: £115

£115

+VAT= £135.13 ref: PRI 2120

The Citizen 120D printer comes supplied with a parallel interface as standard. If you require a serial interface instead, please state ref. PRI 2125 when placing your order with Silica.

STAND OFFER

PRINTER NOT INCLUDED **NEW LOW PRICE!**

CITIZEN PRINTER STAND

For Swift 9, 24, 24e, 200, 240 and 224 Printers

- Helps keep pace with Citizen Printer's powerful paper handling
- Robust & Durable Construction
- Saves space and protects continuous stationery from dust and damage
- Compatible with bottom and rear feed operation

RRP £28
SILICA PRICE: £19

+VAT= £20.33 ref: PRA 1242

9 PIN PRINTERS

FREE - ON REQUEST CITIZEN AMIGA PRINT MANAGER V2.0 **NEW LOW PRICE!**

192 CPS 80 COLUMN

- Citizen Swift 9 - 9 pin - 80 column
- 192cps Draft, 48cps NLO
- 8K Printer Buffer + 3 Fonts
- Parallel Interface
- Graphics Resolution: 240 x 240dpi
- Epson and IBM Emulation
- FREE Colour Kit
- FREE Silica Printer Starter Kit

RRP £239
COLOUR KIT £38
STARTER KIT £25
TOTAL VALUE: £302
SAVING: £143
SILICA PRICE: £159

+VAT= £186.83 ref: PRI 2109

£159

24 PIN PRINTER

FREE - ON REQUEST CITIZEN AMIGA PRINT MANAGER V2.0 **NEW LOW PRICE!**

NEW! SWIFT 2 SERIES

SWIFT 240M MONO PRINTER
(COLOUR OPTION AVAILABLE)

SWIFT 240C COLOUR PRINTER

SWIFT 240 MONO

RRP £339
STARTER KIT £25
TOTAL VALUE: £364
SAVING: £125
SILICA PRICE: £239

+VAT= £280.83 ref: PRI 2150

£239

SWIFT 240C COLOUR

RRP £399
STARTER KIT £25
TOTAL VALUE: £424
SAVING: £125
SILICA PRICE: £299

+VAT= £304.33 ref: PRI 2151

£259

24 PIN PRINTERS

NEW! SWIFT 200

FREE - ON REQUEST AMIGA PRINT MANAGER V2.0

270 CPS 80 COLUMN

- Citizen Swift 200 - 24 pin - 80 column
- 270cps SD (15cps), 216 cps Draft, 72cps LQ
- 8K Printer Buffer - 40K maximum
- Parallel Interface
- 6 LD Fonts
- Graphics Resolution: 360 x 360 dpi
- Epson, IBM, & NEC P20 Emulations
- Quarter Printing and Auto Set Facility
- Ultra Quiet Mode - 44.5 dB(A)
- Colour Option Available
- FREE Silica Printer Starter Kit

RRP £269
SILICA STARTER KIT £25
TOTAL VALUE: £294
SAVING: £115
SILICA PRICE: £179

+VAT= £210.33 ref: PRI 2140

£179

NEW LOW PRICE!

FREE - ON REQUEST AMIGA PRINT MANAGER V2.0

192 CPS 136 COLUMN

- Citizen Swift 24x - 24 pin - 136 column
- 192cps Draft, 64cps NLO
- 8K Printer Buffer + 4 Fonts
- Parallel Interface
- Graphics Resolution: 360 x 360dpi
- Epson, IBM and NEC P6 Emulation
- Colour Option Available
- FREE Silica Printer Starter Kit

RRP £489
SILICA STARTER KIT £25
TOTAL VALUE: £514
SAVING: £215
SILICA PRICE: £299

+VAT= £381.33 ref: PRI 2174

£299

INKJET PRINTER

NEW LOW PRICE!

360 CPS 80 COLUMN

- Citizen Project - inkjet - 80 column
- 360cps Draft, 120cps NLO
- 50 Nozzle Head - Whisper Quiet 47dB(A)
- 8K Printer Buffer + 3 Fonts
- Optional HP Compatible Font cards
- Parallel Interface
- Graphics Resolution: 300x300dpi
- HP Deskjet plus emulation

RRP £689
TOTAL VALUE: £689
SAVING: £151
SILICA PRICE: £345

+VAT= £430.38 ref: PRI 2190

£345

NOTEBOOK PRINTER

NEW LOW PRICE!

64 CPS 80 COLUMN

- Citizen PN48 Notebook Printer
- Non-impact Printing on Plain Paper
- 53cps LQ - 4K Buffer + 2 Fonts
- Rear and Bottom Paper Loading
- Parallel Interface
- Graphics Resolution: 360 x 360dpi
- Epson, IBM, NEC P6 & Citizen Emulation
- Powered From Mains, Battery or Car Adaptor

RRP £375
TOTAL VALUE: £325
SAVING: £126
SILICA PRICE: £199

+VAT= £233.63 ref: PRI 2100

£199

ACCESSORIES

SHEET FEEDERS		ORIGINAL RIBBONS	
PRA 1200	£71.38	P18 3200 1250/8x8 8 Black	£2.91
PRA 1215 1240/224/5mm 524	£88.70	P18 3240 1250/8x8 8 Black	£7.15
PRA 1220 1440/274/5mm 924	£82.90	P18 3244 1250/8x8 14 Black	£4.79
PRA 1180 1200	£56.40	P18 3258 724/5mm 924 Colour	£15.83
PRA 1225 Swift 9x 9x 1240/224	£22.25	P18 3248 P64L Single Strike	£3.81
PRA 1100 Swift 240x 24x 24	£35.38	P18 3242 P64L 8x8 Strike	£3.81
PRA 1750 1240/224/5mm 24	£13.95	COLOUR KITS	
		PRA 1238 224/5mm 924/524/224 225	£25.25
		PRA 1240 5x8 1624x	£25.25
		PN48 ACCESSORIES	
		PRA 1180 P64L Battery	£48.70
		PRA 1180 P64L Car Adapter	£29.27
		PRA 1180 P64L Car Adapter	£18.86

Accessories priced inc. VAT & delivery

CITIZEN PRINTERS

FREE DELIVERY
Next Day - Anywhere in the UK mainland

FREE STARTER KIT
Worth £29.38 - With Citizen dot matrix printers from Silica

2 YEAR WARRANTY
(including the dot matrix printer head)

WINDOWS 3.1
Free Windows 3.0 driver with Starter Kit

FREE COLOUR KIT
With every Swift 9

FREE HELPLINE
Technical support helpline open during office hours

FROM SILICA

SILICA SYSTEMS OFFER YOU

- **FREE OVERNIGHT DELIVERY:** On all hardware orders shipped in the UK mainland.
- **TECHNICAL SUPPORT HELPLINE:** Team of technical experts at your service
- **PRICE MATCH:** We normally match competitors on a "Same product - Same price" basis.
- **ESTABLISHED 14 YEARS:** Proven track record in professional computer sales.
- **£12 MILLION TURNOVER (with 60 staff):** Solid, reliable and profitable.
- **BUSINESS + EDUCATION + GOVERNMENT:** Volume discounts available 081-306 0886.
- **SHOWROOMS:** Demonstration and training facilities at our London & Sidcup branches.
- **THE FULL STOCK RANGE:** All of your requirements from one supplier.
- **FREE CATALOGUES:** Will be mailed to you with offers + software and peripheral details.
- **PAYMENT:** Major credit cards, cash, cheque or monthly terms.

Before you decide when to buy your new printer, we suggest you think very carefully about WHERE you buy it. Consider what it will be like a few months after you have made your purchase, when you may require additional peripherals and accessories, or help and advice with your new purchase. And, will the company you buy from contact you with details of new products? At Silica Systems, we ensure that you will have nothing to worry about. We have been established for almost 14 years and, with our unrivalled experience and expertise, we can now claim to meet our customers' requirements with an understanding which is second to none. But don't just take our word for it. Complete and return the coupon now for our latest FREE literature and begin to experience the "Silica Systems Service".

MAIL ORDER HOTLINE
081-309 1111

SILICA SYSTEMS

MAIL ORDER: Order Lines Open: Mon-Sat 9.00am-6.00pm No Late Night Opening	1-4 The Mews, Hatherley Rd, Sidcup, Kent, DA14 4DX No Late Night Opening	Tel: 081-309 1111 Fax No: 081-308 0608
LONDON SHOP: Opening Hours: Mon-Sat 9.30am-6.00pm No Late Night Opening	52 Tottenham Court Road, London, W1P 0BA No Late Night Opening	Tel: 071-580 4000 Fax No: 071-523 4737
LONDON SHOP: Opening Hours: Mon-Fri 9.30am-7.00pm (Sat 10am-6.30pm) Late Night Thursday - 8pm	Selfridges (1st Floor), Oxford Street, London, W1A 1AB Late Night Thursday - 8pm	Tel: 071-629 1234 Extension: 3014
SIDCUP SHOP: Opening Hours: Mon-Sat 9.00am-5.30pm No Late Night Opening	1-4 The Mews, Hatherley Rd, Sidcup, Kent, DA14 4DX Late Night Friday - 7pm	Tel: 081-302 8811 Fax No: 081-309 0017
ESSEX SHOP: Opening Hours: Mon-Fri 9.30am-5.30pm (Sat 9.00am-6.00pm) No Late Night Opening	Keddies (2nd Floor), High Street, Southend-on-Sea, Essex, SS1 1LA No Late Night Opening	Tel: 0702 462426 Fax No: 0702 462363

To: Silica Systems, AMFOR-0293-55, 1-4 The Mews, Hatherley Rd, Sidcup, Kent, DA14 4DX

PLEASE SEND A BROCHURE ON THE CITIZEN RANGE

Mr/Mrs/Miss/Ms..... Initials:..... Surname:.....

Company Name (if applicable):.....

Address:.....

Postcode:.....

Tel (Home):..... Tel (Work):.....

Which computer(s), if any, do you own?.....

55M

Understanding Imagine 2.0

Reference Book ■ £15.95 ■ Alternative Image (0533 440041)

BRILLIANT AS IMAGINE 2.0 may be as a 3D modelling and rendering system, there are a lot of people who don't realise this because they just cannot get to grips with the program. The complexity of the interface and the huge range of functions and options make it one of the densest packages to learn on the Amiga.

The problem is not exactly helped by the manuals that Impulse have managed to provide to go with the two versions of the programs. The first is so minimal that not all the features are even mentioned, let alone explained. Dedicated users could have hours, days, months of fun trying to fathom things just by trial and error – which is perhaps the best way to learn, but painfully slow and frustrating nonetheless.

The second manual goes to the other extreme and is so dense a tutorial that dipping in for reference is almost impossible. Luckily for *Imagine 2* users, Steven Worling has produced a new reference book – *Understanding Imagine 2.0* – and it is not only by far the easiest way to learn the system, but also one of the best manuals available for any 3D program.

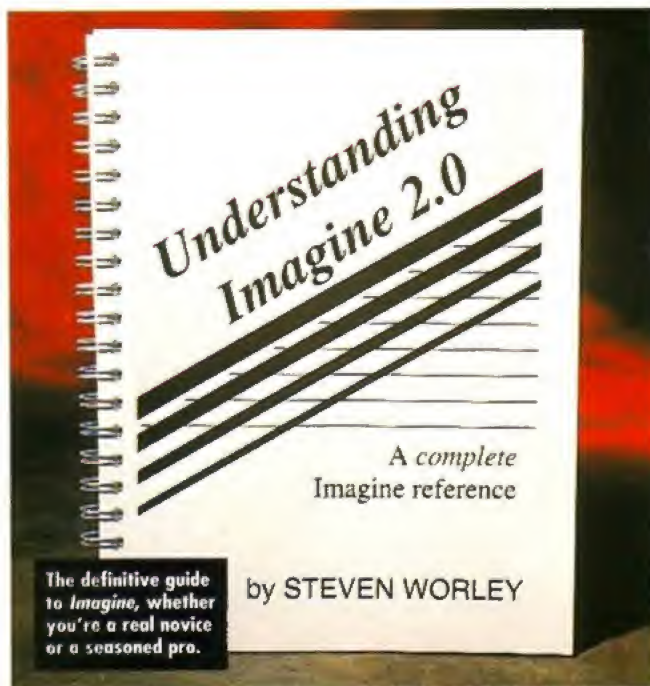

The book steadily works its way through each of *Imagine's* powerful editors, explaining every function and quirk, solving likely problems and concentrating extra effort on the most difficult or special aspects of the system. The style is easy and chatty but precise and informative at the same time. No stone is left unturned. Even after four years of using Impulse products from *Turbo Silver* onwards, and two years of effort on *Imagine*, I learned something new on almost every page!

At the end of the 'manual' proper are 70 pages of appendices detailing problem workarounds, fun tricks, tips, ideas, object creation strategies and detailed descriptions of all of the textures and F/X, many of which are useful in any 3D program.

The only real problem with *Understanding Imagine 2.0* is that it is almost a bootleggers' charter at only £15.95. Nevertheless, if you own *Imagine* you just have to buy this book. *Imagine 2.0* is arguably the best 3D system on any desktop computer. And now mere mortals can use it too.



AMIGA FORMAT

146

FEBRUARY 1993



Real Things – Dogs

Animated clip art ■ £30 ■ Living Data

I AM NONE too partial to dogs. Hot dogs maybe, but dogs anywhere closer than *One Man and His Dog* I can do without. So dogs on a computer screen are just about in the right place for me. Nevertheless, it's a mark of RGB's success with the realism of *Real Things – Dogs*, that, even behind the screen, prolonged experimenting with the latest addition to the *Real Things* series has made me feel more than a little uncomfortable at times.

The *Dogs* package consists of two disks of animbrushes and animations suitable for using in *Deluxe Paint III* or *IV*, plus the usual thorough RGB tutorials and user guides. Nine breeds are covered; some in more detail than others. Once again – like *Safari* and *SeaLife* – all of the images are from frame-grabbed

video, though some hand touching-up has been necessary. With so many copies of the HAM *Deluxe Paint IV* now available, HAM versions of some animals are provided, and these add considerably to the realism. Of all animals though, perhaps dogs are the least enhanced by the extra colour depth of HAM because they are quite limited in their range of shades.

As well as the introduction of HAM, RGB have introduced Chaining. Previously, each animbrush has had one complete movement of an animal – walking, hovering, swimming across the screen. If this method of animation is to progress, animators need to be able to link together several types of movement – changing direction, standing up and walking, running up to and then attacking prey etc. The

'Chaining' together of several movements in *Dogs* is the first example of what promises to be a very powerful tool.

Looking at the complete series of *Real Things*, a steady progression is obvious. *Horses* was well executed but obviously hand drawn. *Humans* and *Birds* were also 'just' produced the hard way, from scratch but with more skill and a real feeling for movement – especially *Birds*.

Safari and *SeaLife* – originating from digitised originals – were far more realistic especially in the naturalistic movement. Now *Dogs*, with both HAM colour depth and the new concept of Chaining, has made another leap of development.

Nevertheless, by playing with lo-res images in *DPaint* again it is obvious how far the Amiga has fallen behind in the graphics area compared with the Mac and PCs. Huge chunky pixels and gross colour banding make it difficult to take this level of Amiga graphics seriously. This is not the fault of *Real Things Studios* who are trying their best on a limited system. Fortunately along comes the Amiga 1200 and the AGA. Let's hope Living Data will progress even further with the huge leap of quality to 8-bit colour and 800x600 resolution. No more dogs though please!

The *Real Things* series is steadily progressing – *Dogs* has HAM colour depth and the new Chaining animation feature.

REAL THINGS – DOGS is available from RGB Studios 0825 732666



T

HE FINAL WORD

...in Word Processing with Perfect Printing

From the makers of Pen Pal comes a brand new, unique WYSIWYG Word Processing package, that's simply the only choice for those who demand the most from their Amiga.

Final Copy II is not only the Amiga's most powerful Word Processor with every feature you'd expect - plus many more found normally in DTP packages - but also the only Word Processor that gives superb scaleable outline fonts from any Amiga - even 1.3's. Imagine outputting to your printers highest resolution, with almost Postscript™ laser perfection - no matter which printer you may have. Even with a simple nine pin dot matrix you'll get perfect printing* from Final Copy's 20 smooth outline typefaces that are included!

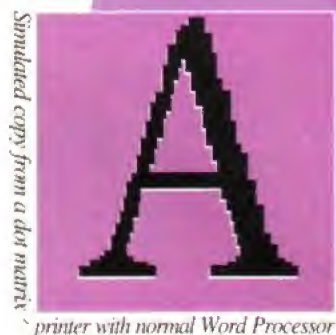

Final Copy II
Word Processor for the Amiga®



from SoftWood, Inc.
the makers of
Pen Pal



With its powerful new features, there's no better Word Processor/Publisher for your Amiga. You'll quickly realise the benefits which were once the exclusive preserve of the Macintosh™ and other high end publishing systems.



With multiple newspaper style columns and integrated drawing tools - for boxes, borders, squares, lines at any angle, ovals, circles, arrows etc., plus colour text, along with many other formatting tools - your documents will look and read just as you want them to.

Final Copy II includes a 110,000 word British-English Collins Proximity Spelling Detector & Corrector, to help typing errors become a thing of the past, along with an 826,000 synonym Thesaurus, for that extra inspiration.

Final Copy II is so easy to learn and use, that you'll become an accomplished author in no time at all - but if you need extra help you're not on your own as our support hotline is there for all UK version users. Look out for the UK logo on the box!

...Final Copy II

Only £99.95

FROM ALL GOOD SOFTWARE DEALERS

Compatible with...

Amiga - A 500/600/600HD/1500/2000/3000. System requirements... min. of 1Mb. RAM and two Floppies or a Hard Disk Drive [A600HD requires at least 1.5Mb].

*Any Workbench supported graphic printer, colour or mono, including... Citizen 120D, 124D, 224, Swift 9/24, 200/240; Star LC10, 20, 200, 24-200, and XB Series; Canon BJ10ex; HP Ink/Paintjet; Postscript™ devices and many more.

Trade Distribution by...

- Centresoft/IBD ♦ HB Marketing ♦ Leisuresoft ♦
- Meridian Distribution ♦ SDL/Prodis ♦

Dealers... Please call Harwoods for your supply of leaflets and inclusion in the list of stockists we provide to customers.

*United Kingdom version imported & supported by...

GORDON HARWOOD Computers

Gordon Harwood Computers • New Street • Alfreton Derbyshire • DE55 7BP • Telephone: 0773 836781

Final Copy II encompasses a whole range of other advanced features, here's just a selection:

- ◆ Uses the latest Workbench 2 Style interface on all Amigas
- ◆ On screen command ribbon controls (format your document with the simple touch of a button)
- ◆ 25% to 400% editable page reduction and magnification command
- ◆ Title page, master pages & style sheets
- ◆ Right/left pages with binding offset
- ◆ Open multiple documents
- ◆ Fast mouse document panning and zoom/un-zoom
- ◆ External and internal mail merging
- ◆ Cut, copy and paste
- ◆ Search and replace
- ◆ On screen maths
- ◆ Auto-hyphenation
- ◆ Import, resize and crop IFF, HAM and 24Bit ILBM graphics and auto-flow text around them
- ◆ Text over graphics
- ◆ Outline fonts on all Amiga screens, and any non-Postscript™ or Postscript™ compatible printer
- ◆ 4 point up to 300 point [over 4" high] smooth text printing
- ◆ Text leading and spacing controls
- ◆ Condensed and expanded characters
- ◆ Positive and negative obliquing
- ◆ Background printing, allowing simultaneous editing & printing of two or more documents
- ◆ Fast proof printing facility
- ◆ Comprehensive range of additional attractive font volumes available.

Please rush my personal copy of the new Final Copy II information pack, including samples from popular printers, and a list of stockists to... [clip the coupon or call 0773 836781 now!]

Name & Address:

Please include your postcode
AMF 2/93



Oki launch into the Amiga market with their new light-emitting-diode printer.

Had laser printers better watchout?

Jason Holborn writes...

Oki OL400

£899 ■ LED Printer ■ Oki

OK, I KNOW what you're thinking - what's an LED printer, right? Well an LED printer isn't that different from conventional laser printers...

Heading Oki's offensive into the Amiga market is the OL400, a new printer that offers LED printing technology to the masses.

The paper tray (which can hold up to 200 sheets of standard copier paper) sticks out of the front of the casing...

The OL400 comes complete with three emulation modes, so getting your favourite program to talk to the printer shouldn't be a problem.

The Oki is a well-designed and good-looking printer that brings you quality results at inexpensive prices.

The Oki printer comes with Swiss and Dutch fonts, which are the same as Helvetica and Times.



Table showing HP LaserJet Emulation settings for various fonts like Helvetica, Courier, and Times.

Workbench 1.3 and 2.04 is sad to say the least, but rumour has it that Commodore have improved the driver in Workbench 3.0...

The OL400 is equipped with a decent selection of typefaces, especially when the printer is run in its native HP LaserJet emulation mode.

The OL400 certainly shares more than a few similarities with more conventional laser printers. For starters, it's what the techies call a 'page printer'...

Printers such as the OL400 are designed primarily for DTP work, so you're probably better off with a dot-matrix or an inkjet if printing text is your only requirement.

In use, the OL400 proves itself to be a capable performer. Although printing speed is not exceptional (four pages per minute)...

Prices for the OL400 can vary between dealers. Oki actually quote a retail price of £899 for the basic 512k OL400...

Another big advantage of the OL400 printer is the low price of the toner cartridges - instead of the usual £70+ that you find with laser printers...

OKI OL400 phone Oki for your local dealer 0800 525 585

Superb printouts make the Oki the ideal choice if you use your Amiga for DTP, or if you need quality letterhead printouts.

Amiga Desktop Publishing advertisement featuring a woman's face and text about the software.

Oki OL400 advertisement with a red background, listing features like SPEED, DOCUMENTATION, PRINT QUALITY, and VALUE, along with a 90% logo.

AMIGA FORMAT

148

FEBRUARY 1993

Deluxe Work Centres

RSD
CONNECTIONS
LTD

**AMIGA
500**

£49.95
inc. VAT
S.R.P.

**AMIGA
600**

£39.95
inc. VAT
S.R.P.

THE IDEAL COMPANION FOR YOUR AMIGA 500 & 600

MANUFACTURERS, SUPPLIERS OF
COMPUTER CABLES,
PERIPHERALS AND ACCESSORIES



BOTH PACKS INCLUDE:

FREE
DUST COVER
MOUSE HOLDER
MOUSE PAD

**JOYSTICK/MOUSE
CABLE SET
A500 ONLY**



THESE WORK CENTRES ARE AVAILABLE
FROM THE FOLLOWING INDEPENDENT DEALERS:-

ACCRINGTON	PY COMPUTERS	0254 235345	FINCKLEY	ADAMS WORLD	081 446 7120	MILTON KEYNES	EVESHAM MICROS	0908 230898	SCURTHORPE	THE COMPUTER STORE	0724 857985
BANBURY	SOFTSPOT	0295 268921	FROME	AVALON COMPUTERS	0373 452895	NEWCASTLE-UNDER-LYME	COMPUTER HOUSE	0782 711237	SHEFFIELD	THE COMPUTER STORE	0742 780083
BARNSELY	THE COMPUTER STORE	0226 284124	GATESHEAD	MAUGHAN MICROS	091 493 2308	NEWCASTLE-UPON-TYNE	MICROTYPE	091 261 4088	SHEFFIELD	THE COMPUTER STORE	0742 569121
BEXLEY HEATH	HI-TEK	081 303 4862	HALFAX	THE COMPUTER STORE	0422 369077	NORWICH	ONE STEP BEYOND	0603 663796	SHREWSBURY	STD COMMUNICATIONS	0743 231763
BIRMINGHAM	EVESHAM MICROS	021 446 5050	HARROW	ADAMS WORLD	081 863 7262	NORWICH	SOFTWARE EMPORIUM	0603 633362	SOUTHAMPTON	L.G. COMPUTERS	0703 771399
BIRMINGHAM	3IN 1 DISK	021 616 1168	HASTINGS	INVACTA SOFTWARE	0424 444615	NORWICH	VIRKING COMPUTERS	0608 425209	SOUTHEND-ON-SEA	ESTUARY COMPUTERS	0702 614101
BOURNMOUTH	LANSDOWNE COMPUTERS	0202 290145	HITCHIN	KOTECHA	0462 436622	NOTTINGHAM	LONG EATON SOFTWARE	0602 728555	SOUTHGATE	LOGIC SALES	081 882 4942
BRADFORD	THE COMPUTER STORE	0274 732094	HULL	THE COMPUTER STORE	0484 514405	NOTTINGHAM	HOME AND BUSINESS	0602 598645	ST AUGUSTINE	A.B. & C. COMPUTERS	0726 64463
BRIDPORT	TIGERSOFT	0398 27691	HULL	THE COMPUTER STORE	0482 25536	OLDHAM	HOME AND BUSINESS	061 633 1608	STOCKTON	TOPSOFT	0642 670503
BRIGHTON	GAMER COMPUTERS	0273 728681	ILKESTON	MERLIN EXPRESS	0602 441442	OXFORD	SOFT SPOT	0865 794202	SWANSEA	MERTEC PLC	0792 467980
BURNLEY	BURNLEY COMPUTER CENTRE	0282 34772	IPSWICH	BITS AND BYTES	0473 233678	PETERBOROUGH	LOGIC SALES	0733 49696	THURROCK	DATABASE COMPUTERS	0708 890976
CAMBRIDGE	EVESHAM MICROS	0223 320898	KINGSTON-UPON-THAMES	BARHAMAN COMPUTERS	081 546 5941	PLYMOUTH	COMPUTER BASE	0752 668635	THURROCK	INVACTA SOFTWARE	0892 511542
CANTERBURY	COMPUTER WORLD	0227 786788	LEEDS	A.N.B.	0532 326341	PORTCHESTER	WE-SERVE	0708 325354	WAKEFIELD	THE COMPUTER STORE	0924 290159
CHESHURT	LOGIC SALES	0992 25353	LEEDS	THE COMPUTER STORE	0532 429284	PORTSMOUTH	BITS AND BYTES	0795 871890	WALLASEY	COMPSHOP	051 639 3041
COVENTRY	K. SOFT	0203 555228	LEIGH-ON-SEA	PLATINUM COMPUTERS	0702 47082	RAYLEIGH	P. D. S.	0702 614131	WESTON-SUPER-MARE	JACKIE'S CORNER	0504 620922
DERBY	THE COMPUTER STORE	0332 202960	LOUGHBOROUGH	K.C. COMPUTER EMPORIUM	0569 211799	READING	PLATINUM COMPUTERS	0268 779909	WOKING	HARPERS	0483 756601
DONCASTER	THE COMPUTER STORE	0302 325260	LUTON	W.T.S. ELECTRONICS	0582 491949	REDFORTH	COMPUTER CARE	0734 393615	WOLVERHAMPTON	MICRO BUSINESS CENTRE	0902 29823
DUNDEE	BITS AND BYTES	0382 22052	MAIDSTONE	COMPUTER WORLD	0622 677115	RUGBY	SOFT SPOT	0527 585209	WORTHING	WORTHING COMPUTERS	0903 210861
ENFIELD	ADAMS WORLD	081 542 0243	MANCHESTER	MIGHTY MICRO	051 224 8117	SALISBURY	COMPLEAT COMPUTERS	0786 572309	YORK	THE COMPUTER STORE	0904 848834
FARNHAM	ATHENE COMPUTERS	0329 823000	MANSFIELD	MANSFIELD COMPUTERS	0623 637022		COMPUTER PLACE	0722 414416			



The Disc Company have brought DTP within the reach of the masses with the cheapest Amiga DTP program yet.

Jason Holborn says 'Wow!'

The Publisher

£49.95 ■ Desktop publishing ■ The Disc Company

AMIGA FORMAT

150

FEBRUARY 1993

IN DESKTOP PUBLISHING the most expensive aspect can often be the software – capable packages like *Professional Page* can cost over £200 – so you've got to be serious about DTP to warrant the expense. In an attempt to bring DTP to the masses, though, The Disc Company have launched *The Publisher*, a mono-only program that can be used to produce anything from posters and fliers to complete magazines.

At under £50, this is the cheapest Amiga DTP program available – even *PageSetter 2* (its nearest rival) will set you back double the asking price of *The Publisher*. Surely at this price, it can't be any good... or can it? It comes on three disks containing two program modules and a plethora of fonts. Before you can start laying out the next issue of your football or Amiga-users' fanzine though, you have to install *The Publisher* on to a separate set of work disks or your hard disk (definitely a recommended extra, simply because of the amount of disk swapping that's needed).

Installation is fairly simple and involves setting up a couple of assignments that tell *The Publisher* and its program modules where everything can be found. It comes complete with programs that automate this process just in case you don't understand AmigaDOS.

Like most DTP programs, it is memory hungry. Unless you've got at least 2Mb of RAM, don't even attempt to run the program. The Disc Company recommend a minimum of

THE PUBLISHER is available from The Disc Company in France on 010 331 4910 9995

Even a magazine such as *Amiga Format* could be laid out using *The Publisher* – and here's the proof!

Standard Adobe Type One fonts can be used with *The Publisher* without having to convert them first.



1.5Mb, but this is unrealistic considering the memory overheads that creating even a simple document will demand. On a machine with 2Mb and a hard disk though, it is a very useable system.

The Publisher comprises two programs – the layout program and a separate PostScript interpreter. Why a PostScript interpreter? Well, this program is important because *The Publisher* is not capable of printing to any printer other than a PostScript device.

Obviously few home users have Postscript printers, so The Disc Company have included the interpreter to enable the output to be printed on a standard Preference-supported printer. If all this sounds familiar, you'd be right – *The Publisher* is actually a slightly cut-down version of Emerald Graphics' *Saxon Publisher*, a previously expensive (£200!) DTP program that proved only slightly more popular than the Inland Revenue.

Like *Saxon*, it does not have a straightforward process for laying out a page. Instead of simply opening up a box and dropping some text or graphics into the box (à la *ProPage*), with this program it requires more planning. Although pages are still built up from a series

THE PUBLISHER Version 1.00 Free Store 87298

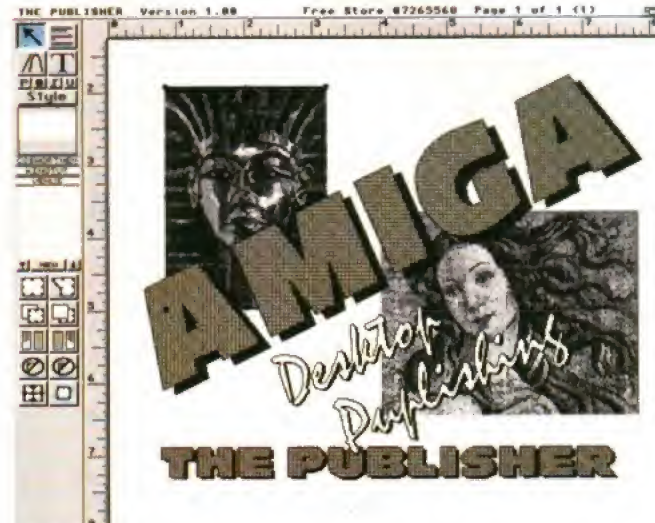

of boxes, each and every element (text and graphics, for example) is loaded into the program and then assigned to 'tags'. To transfer the element that you have loaded into a box, you then select the box and click on the tag that it is to be assigned with. OK, it's different from *ProPage*'s approach, but you'll probably find this is a more flexible approach.

Text can be flowed directly into a box by loading a text file created in any one of a number of word processors (*The Publisher* can read files from *Excellence!* and *Kindwords*, among others) or typed directly into the box using the program's built-in text-editing facility. Once the text is in the box, you then define a 'style tag' that dictates the type of font used, its point size, leading, tracking etc. Unlike *ProPage*, it can also automatically add both a shadow and an outline around any text that you choose to edit. And, because the program uses standard Adobe Type One outline fonts, you can also stretch and squeeze text within a box with no degradation in print quality.

The Publisher's direct support of Adobe Type One fonts is perhaps one aspect of the program that helps it to score well. Although Type Ones are still not seen as an accepted standard on the Amiga, getting your hands on

DON'T MISS OUR AMAZING NEW BROCHURE FEATURING ALL THE VERY LATEST IN AMIGA AVAILABLE AT ALL STORES NOW

WANT A 1200 With Workbench 3? GOT A 500 P/X IT & THE 1200 IS ONLY £299.95 ALL PRICES INCLUDE VAT

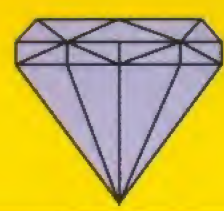

BARGAINS FOR THE MONTH!
Philips 8833 MkII Monitor with Turbo Challenge II £199.95
+ Free F19 Stealth Fighter for the first 500 customers on this product.
Roclite Drive with Anti click/Virus £59.95

THE CAPTAIN'S 1200, 3000 & 4000 CENTRE

MAIL ORDER HOTLINE: PHONE 071 580 4259

NEW AMIGA 1200

68020 processor running at 14.19MHz. 2Mb RAM expandable to 10Mb, an amazing, 16 million colours, Work bench 3, AA chipset, Built in TV modulator. 512K Operating system, 32-bit CPU slot, 880K 3.5" floppy drive, 4 sound voices & 4 great games Zool, Striker, Transwrite & Pinball Dreams.

Only £399.99

Why not try Diamond's amazing Part Exchange offer on the 1200. We will give you the 1200 for £299.95 against ANY old Amiga, presuming it's in fair condition. (Subject to managers discretion)

THE NEW AMIGA 3000

25MHz processor, 100 Mb hard disk, 2Mb Fast RAM, 2Mb Chip RAM. **£1479.95 INC VAT**

THE NEW AMIGA 4000

68040 Amiga DSOS 3, 6Mb RAM, 120Mb Hard Disk **£2099.95 INC VAT**

GRAPHICS & VIDEO

- New ICD Flicker fixer **£209**
- GVP Impact Vision 24 Bit Card (1500/2000/3000) from **\$1550**
- DCTV (Pal Version) **\$440.00**
- Rocgen **\$89.95**
- Rocgen + **\$124.95**
- Rendale 8802 **\$119.95**
- Rendale 8806 RGB **\$499.00**
- Commodore 2300 Int G2 **\$99.00**
- G2+ **\$999.00**
- Video Pilot V330 (Video Editing) **\$1173**
- Philips Editing System **\$399.00**

AVIDEO 24
 24-bit graphics for the A500. 16.8million colour frame buffer. **\$589.00**

NEW 24 BIT OPAL CARD
 24-bit colour. 16.8 million colours.Full animation. Fits all Amigas **\$849.00**

GENERAL ACCESSORIES

MONITORS & TV'S

- 8833MkII +Turbo Challenge II **\$199.95**
- CBM 1960 Monitor **\$449.95**
- CBM Flicker Fixer **\$299.95**
- Philips 14"SVGA monitor, suitable for use with A3000 or 1500 with flicker fixer **\$229.95**
- Please add \$14.95 for connecting lead
- NEW PHILIPS MODEL 220 CDI MEMORY UPGRADES \$449**
- New Smart Card memory upgrade (A600) 2Mb only **\$129** 4Mb only **\$169**
- New 2.04 Official Upgrade with manuals & ROM only **\$79.95**
- A500 Plus 1Mb Expansion **\$39.95**
- New A600 1Mb Expansion **\$54.95**
- Supra 500RX 2Mb Expan.(500/500+) **\$139.95**
- 512K RAM Expansion + Clock (500) **\$34.95**
- Above without clock **\$29.95**
- 1.5Mb Mb Expansion (Not Plus) **\$79.95**
- 1Mb Expansion with Thru-Port (500) **\$49.95**
- 8Mb RAM Board for A1500 or 2000 **\$79.95**
- Aries Board 0Mb **\$69.00**
- For each 2Mb RAM add

INTERNAL DRIVE KIT
 Replacement A500 Internal 3.5" drive kit, fully compatible with 1Mb unformatted capacity. Comes with easy to follow guide **\$59.95**

- EMULATORS**
- Golden Gate 386-20 for 1500/2000 **\$349.00**
- Golden Gate 486SX25. 1500/2/3/4000 **\$749.00**
- GVP 16MHz PC-286 1500/2000 **\$239.99**
- Vortex AT Once Plus 16MHz **\$214.99**

MICE
 Naksha Upgrade Mouse **\$22.95**
 New Roboshift, Auto sensing Joystick/Mouse switch box **\$13.95**

TRACKBALL
 One hand control unit, after using this you will never want a mouse again **\$29.95**

A500 ROM SWITCHER
 Switching between versions of Kickstart on your A500 is could not be easier than with our new ROM switcher. **\$9.95**
 Kickstart 1.3 ROM (supplied seperately) **\$29.95**
 Kickstart 2.4 ROM (supplied seperately) **\$39.95**

POWER SUPPLY
 Commodore A500 A600 PSU with the switch mode (\$10 OFF with P/X) **\$49.95**

SOUND EXTRAS
 Amiga Sound Enhancer **\$35.99**
 Stereo Speakers **\$39.95**

CONTROL CENTRE
 Turn your Amiga into the ultimate hi-tech intergrated workstation environment **\$34.99**

GVP HARD DRIVES / ACCELERATORS

- AMIGA 1500 / 2000 HARD DRIVE**
- Impact Series II HC8+ Control Card only **\$134.99**
- GVP HC8 + 52Mb Quantum for 2000 **\$263.95**
- GVP HC8 + 80Mb Quantum for 2000 **\$328.95**
- Impact Series II HC8+ & 240Mb Hard drive **\$639.99**
- Impact Series II HC8+ & 420Mb Hard drive **\$1169.99**
- GVP Impact Vision 24 Bit Card **\$1499.00**
- AMIGA 1500 / 2000 ACCELERATOR CARDS**
- G-Force 030-25MHz with 1Mb 32-Bit RAM **\$549.99**
- G-Force 030-40MHz with 4Mb 32-Bit RAM **\$899.99**
- G-Force 030-50MHz with 4Mb 32-Bit RAM **\$1269.99**
- G-Force 040-28MHz with 2Mb 32-Bit RAM **\$1699.99**
- FLOPTICAL DRIVE \$549.90 (21Mb disk \$57.80)**

AMIGA A500 HARD DRIVES

- GVP HD8 + 52Mb Quantum **\$318.95**
- GVP HD8 + 80Mb Quantum **\$368.95**
- GVP COMBO ACCELERATOR FOR A500**
- GVP A530 + 80Mb Quantum **\$658.95**
- A530 Combo 40MHz + 120Mb H/D **\$728.95**
- A530 Combo 40MHz + 200Mb H/D **\$918.00**
- 68882 Co-Processor for A530 **\$234.99**
- GVP MEMORY RAM MODULES**
- Series II RAM 8 RAM Card for Amiga 1500/2000 with 2Mb **\$149.99**
- 32 bit 60ns 1Mb SIMM for Accelerator Cards (A530 + G FORCE) **\$64.99**
- 32 bit 60ns 4Mb SIMM (A530 + G FORCE) **\$179.99**

COMPONENT SHOP

QUANTUM H/DISKS	IDE	SCSI
42Mb	\$139.83	\$149.95
127Mb	\$257.33	\$269.00
240Mb	\$429.96	\$429.96

New floptical Drive **\$549.90**
 21Mb disk **\$57.80**

SYQUEST DRIVE
 Removeable cart. 44Mb 28ms **\$299.00**
 CONTROLLER for above add **\$69.95**

ROM SWITCHER Now Available
 1.3 - 2.04 ROM Switcher **\$9.95**
 1.3 ROM available @ **\$29.95**
 2.04 ROM available @ **\$39.95**

Workbench 3.0 P.O.A.

CAPTAIN'S CHIP SHOP

- 4X256K DRAMS For A590'S etc **\$3.50**
- 1X1MB DRAMS For Bup/Supra **\$3.50**
- 1x9Mb SIMMS For NEXUS/GVP/Rochard **\$34.99**
- 4x9Mb SIMMS For GVP etc **\$169.95**

DISK DRIVES
 AMIGA Internal **\$59.95**
 CDTV drive **\$74.95**
Roclite Slimline
 no click & Virus protection on track 0. **\$59.95**

Diamond Amiga Drive \$49.95

CAPTAIN DIAMOND'S ULTIMATE A600/1200 HARD DISK OFFER

- 20Mb (limited stock) **\$149.95**
 - 60Mb **\$175.00**
 - 80Mb **\$229.00**
 - 120Mb **\$359.00**
 - 130Mb **\$379.00**
 - 160Mb **\$479.00**
 - 200Mb **\$549.00**
- Turn your A600/1200 with a single floppy drive into the ultimate machine with a Hard Disk. 12 months return to base. Only £24.95 for fitting.

: JANUARY SALE NOW ON : JANUARY SALE NOW ON : JANUARY SALE NOW ON : JANUARY SALE NOW ON : JANUARY SALE NOW ON : JANUARY SALE NOW ON : JANUARY SALE NOW ON : JANUARY SALE NOW ON : JANUARY SALE NOW ON : JANUARY SALE NOW ON :

: JANUARY SALE NOW ON : JANUARY SALE NOW ON : JANUARY SALE NOW ON : JANUARY SALE NOW ON : JANUARY SALE NOW ON : JANUARY SALE NOW ON : JANUARY SALE NOW ON : JANUARY SALE NOW ON : JANUARY SALE NOW ON : JANUARY SALE NOW ON :



JAMES STEVENSON 1991

We also take Amiga's in px against PC's, come in for a demo.

P/X your old 500 for a new Amiga 1200 with Workbench 3.00 for only **£299.95**
ALL PRICES INCLUDE VAT

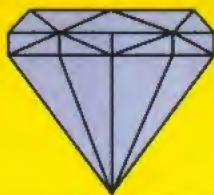

Part exchange ex demo A500 with 3 months warranty, **£199.95**
 Ex demo A590's from **£199.95**
ALL PRICES INCLUDE VAT

10 Disks in a library case **£5.00**

CAPTAIN DIAMOND'S PERIPHERALS PAGE

: JANUARY SALE NOW ON : JANUARY SALE NOW ON : JANUARY SALE NOW ON : JANUARY SALE NOW ON : JANUARY SALE NOW ON :

: JANUARY SALE NOW ON : JANUARY SALE NOW ON : JANUARY SALE NOW ON : JANUARY SALE NOW ON : JANUARY SALE NOW ON :

APPLICATION	SOFTWARE
Graphics & Digitising	Wordprocessing & DTP
Deluxe Paint IV £59.99	Transwrite £29.99
Digi view Media Station £119	Kindwords 3 £34.99
Infro CAD Plus £64.99	Final Copy £99.95
X CAD 2000 £89.99	Wordsworth V1.1 £59.95
X CAD 3000 £239.99	Excellence 3 £79.95
Image Master £106.99	Home Office Kit £49.95
Image Finder £39.95	Pagesetter 2 £39.99
Vista £64.99	Page Stream 2.2 £129.95
Pro Vista £64.99	Saxon Publisher £159.95
VDI Amiga Colour Solution £99.00	Propage 3 £139.95
Pro Draw 3 £89.95	
Music, Midi & Sound	Development & Utilities
Audio Engineer +2 £189	AMOS Starter Pack £39.95
Audiomaster 4 £44.99	Easy AMOS £24.99
Bars & Pipes Pro £174.99	AMOS 3D £29.99
Dr T Copiest Apprentice £69.99	AMOS Compiler £24.99
Dr T KC5 Level II V3.5 £179.95	Cross Dos £34.99
Music X 1.1 £44.95	Dos 2 Dos £24.99
Stereo Master £29.95	Disk Master £34.99
Pro Midi 2 Interface £19.99	Dev Pack 3 £49.95
Techno Sound Turbo £34.99	Directory Opus £24.99
	Lattice C 5.1 Dev Syst £159.95
Video Tiling	Quater Back V5 £34.99
Amiga Vision £49.99	Superbase Pro 4 £149.95
Big Alternative Scroller £39.95	X Copy Pro 5.2 £29.95
Broadcast Titrer 2 £174.99	Hi Speed Pascal £69.95
Font Pack 1 for above £74.99	Hyper Book £39.99
Font Pack 2 for above £74.99	
Pro Video Post £174.99	Accounting
TV Show £49.99	Home Accounts 2 £34.99
TV Show Pro £59.99	System 3 £39.99
TV Text Pro £69.95	Area Accounts £89.99
Video Director £99.00	Pro Calc £99.99
Can Do V1.6 £74.99	Advantage £34.99
Show Maker £149.00	Day By Day £24.99
Scala 500 £69.99	
Scala Pro £175.00	Educational
	A D I Maths 11-12 £19.95
Animation & Rendering	A D I Maths 12-13 £19.95
Art Dept. £44.99	A D I English 11-12 £19.95
Art Dept Pro 2 £119.95	A D I English 12-13 £19.95
Imagine 2 £174.99	Distant Suns 4 £49.95
Map Master for Imagine £44.99	Fun School s (Each) £19.95
Morph Plus £149.95	GB Route £49.95
Presentation Master £169.95	
Surface Master for Imagine £24.99	APPLICATION STAR BUYS
Real 3D Beginners £84.99	Final Copy £99.95
Real 3D Pro £229.95	Wordworth 2 £79.95
Sculpt Animate 4D £199.95	Home Office Kit - Includes Spreadsheet, Database & Word Processor £49.95
CLUB MEMBERS PRICE ONLY (Prices are already discounted)	

Printer Driver Disk for your Amiga, **£5.00** (Please specify model)

DOT MATRIX PRINTERS		CITIZEN SWIFT	
STAR LC20	£113.97	9 COL	£154.95
STAR LC100 Colour	£141.95	224 COL	£205.00
STAR LC 200 Colour	£165.95	24E COL	£235.00
STAR LC 24-20	£175.95	240 COL	£250.27
STAR LC 24/200 MONO	£195.95	24X	£303.15
STAR LC 24/200 COL	£237.35	24X COL	£349.00
STAR ZA 200 COL	£269.00	SEIKOSHA SP 1900+	£99.95
STAR XB 24 200 COL	£368.95	SEIKOSHA 2400	£129.95
STAR XB 24 250 COL	£435.92	SEIKOSHA SL92	£175.00
		New Seikosha 24 Pin Col	£174.00

INK JET PRINTERS	LASER PRINTERS
HP DESKJET £295.00	Oki 400 £499
HP DESKJET COL £371.30	NEW Oki OL410 1Mb inc. HP IIIP Emulation £680
HP DESKJET 550C £480.57	OKI LASER 810 £939
CANON BJ10EX £186.83	OKI LASER 830 £939
CANON BJ 20 £287.87	Postscript 2Mb £939
CANON BJ300 £326.65	NEW OKI OL 850. (Feature enhanced OL840) £1499
CANON BJ200 £369.00	
CANON BJ330 £442.97	

AMIGA BOOKS	
Advanced S. Prog. Guide £24.45	Disk Drives Inside & Out £20.95
3D Graphics Prog. Basic £13.95	Amiga For Beginners £12.95
Amiga Basic Inside & Out £17.45	Graphics Inside & Out £24.45
Amiga C Advanced Prog. £24.45	Machine Language £13.95
Amiga C for Beginners £13.95	Printers Inside & Out £24.45
Amiga DOS Inside & Out £13.95	Systems Prog. Guide £24.45
Amiga Dos Quick Ref. £6.95	Best Tricks & Tips £13.95
Desk Top Video Guide £13.95	Making Music On Amiga £24.45

TOP 10 TITLES

Zool	£19.49
Fireforce	£19.49
Road Rash	£19.49
Lotus 3 Ultimate	£19.49
Puffy	£19.49
Humans	£22.49
Pinball Fantasies	£22.49
Sensible Soccer	£19.49
Nigel Mansell	£22.49
Wizkid	£19.45

CLUB MEMBER PRICE ONLY
 Why don't you join Captain Diamond's Discount Club and save a fortune on all your games
Personal callers only
 Normal saving off RRP

25%

AMIGA BUDGET TITLES
 Wolf Child, Thunderhawk, Asterix, Chess Player 2150, Drivin' Force, Skyweek, Live & Let Die, Onslaught, Pipe Mania, Rick Dangerous, Rock 'N' Roll, Soccer, Trivial Pursuit, E-Motion, Dungeon Quest, Shufflepuck Cafe, Predator Tower of Babel, Data Storm, Grand Monster Slam, Powerplay, Kid Gloves, Predator 2, Carv-Up, Corporation, Cadaver, Line of Fire, Teenage Turfies, Back to the Future III, Gunship, Mike Reads Pop, Gazza II, Monty Pythons

ANY FIVE BUDGET TITLES FOR ONLY £20 OR £5 EACH

DIAMOND SHOPS AROUND THE UK		
AMIGA WORLD In the basement of 232 Tottenham Ct Rd London W1 Tel 071 580 4355 FAX 071580 4399	HEAD OFFICE 84 Lodge Road Southampton Tel 0703 232777 FAX 0703 232 679	443 Gloucester Rd Bristol Tel 0272 522044 FAX 0272 521738
NEW SHOWROOM 410 Bath Rd Slough Tel 0628 604555 Fax 0628 668952	1022 Stockport Rd Manchester Tel 061 257 3999 FAX 061 257 3997	Amiga 1063 High Rd Chadwell Heath Romford Tel 081 597 8851 FAX 081 590 8959
144 Ferry Road Edinburgh Tel 031 554 3557 FAX 031 554 2115	406 Ashley Road Poole Dorset Tel 0202 716226 FAX 0202 716160	PC Centre 1045/47 High Rd Chadwell Heath Romford Tel 081 597 8851 FAX 081 590 8959
LONDON CORPORATE SALES Saran Duffy 071 5804355 Fax 071 580 4399		

HOW TO ORDER

Simply telephone through your order, giving your Access, Visa or American Express card number (AMEX has a 3% surcharge), or send a cheque or postal order to our Tottenham Court Rd. Branch
MAIL ORDER Phone.071 580 4259. Minimum Courier Service £17.63
 Corporate Sales:-Account Customers Min. order value = £50. New Accounts min. £500. Allow 10 working days for cheque clearance. Bankers drafts clear same day. All prices are correct at time of going to press. Due to the Christmas rush on magazine release dates this actual advert is valid from January 10th 1993 until February 1993. However many prices have not changed since last month so please contact your local branch for details.

THE DIAMOND PRICE PLEDGE

If, whilst buying goods from us, you can show us a better price for the same goods in stock with one of our UK competitors then we will match it.
 Even if our prices have increased we will honour the price in this advertisement on items in stock as long as you bring this advert with you.
 This pledge applies only to customers relying on this advertisement before the 10th day of the month of publication. It does not apply to competitors prices offered in closing down or stock clearance sales.

MAIL ORDER HOTLINE: PHONE 071 580 4259

PREMIER MAIL ORDER

Titles marked * are not yet available and will be sent on day of release.

Please send cheque/PO/Access/Visa No. and expiry date to:

Dept AF43, 10 Tinkler Side, Basildon, Essex SS14 1LE

Please state make and model of computer when ordering. P&P inc. UK on orders over £5.00. Less than £5.00 and Europe add £1.00 per item. Elsewhere please add £3.00 per item for Airmail. These offers are available Mail Order only. Telephone orders: Mon-Fri 9am-7pm. Saturday and Sunday 10am-4pm. Tel orders: 0268 271172 Fax orders: 0268 271173
Next day service available add £2.50 - ring for details.
Check to see if games are 1 Meg Capacity.

Addams Family.....	16.99
Afterburner.....	6.99
Agony.....	24.99
Airbus.....22.99	
Air, Land, Sea.....	24.99
Air Support.....	19.99
Alien 3.....	19.99
Altered Beast.....	6.99
Amberstar.....	19.99
Amos The Creator.....	29.99
Amos 3D.....	24.99
Amos Compiler.....	19.99
Amos Professional.....	44.99
Another World.....	19.99
Aquatic Games.....	16.99
Arkanoid 2.....	6.99
Award Winners.....	16.99
Archer Macleans Pool.....	16.99
Arsenal FC *.....	16.99
Ashes of Empire.....	22.99
Assassin.....	16.99
Assault on Alcatraz.....	16.99
A - Train *.....	22.99
AVSB Harrier Assault.....	19.99
B.C. Kid.....	17.99
B17 Flying Fortress (1 Meg) *.....	22.99
Batman Caped Crusader.....	6.99
Batman the Movie.....	6.99
Bat 2 * (1 Meg).....	26.99
Battletoads *.....	19.99
Bill's Tomato Game.....	19.99
Billy the Kid *.....	16.99
Birds of Prey (1 Meg).....	22.99
Black Crypt.....	19.99
Blues Brothers.....	8.99
Bonanza Bros.....	16.99
Bubble Bobble.....	6.99
Cabal.....	6.99
California Games 2.....	16.99
Carl Lewis Challenge.....	16.99
Campaign.....22.99	
Castles.....	19.99
Championship Manager (1 Meg).....	16.99
Chaos Engine.....	16.99
Chuck Rock 2 *.....	16.99
Civilisation (1 Meg).....22.99	
Conan The Cimmerian *.....	19.99
Cool World *.....	17.99
Covert Action (1 Meg).....	22.99
Crazy Cars 3.....	16.99
Cruise For A Corpse.....	19.99
Crystal Kingdom Dizzy *.....	14.99
Curse of Enchata.....	22.99
Daley Thompson Challenge.....	6.99
Dark Sun: Shattered Lands *.....	21.99
Dark Queen of Krynn.....	22.99
Death Knights Of Krynn (1 Meg).....	19.99
Deluxe Paint 4.....	54.99
Demonsgate *.....	22.99
Desert Strike *.....	19.99
Dizzy Collection.....	16.99
Doodle Bug.....	17.99
Double Dragon.....	8.99
Double Dragon 2.....	8.99
Double Dragon 3.....	16.99
Dragon Ninja.....	6.99
Dreadnought.....	22.99
Dream Team.....	17.99
Dune.....	19.99
Dungeon Master Chaos.....	19.99
Dynablaster.....19.99	
Easy Amos.....	29.99
Elite 2 *.....	22.99
Epic.....	19.99
Euro Football Champ.....	16.99
Eye of the Beholder (1 Meg).....	19.99
Eye Of The Beholder 2 (1 Meg).....	21.99
Eye of the Storm *.....	19.99
F15 Strike Eagle 2 (1 Meg).....	22.99
F16 Combat Pilot.....	8.99
F19 Stealth Fighter.....	19.99
Falcon 3 *.....	24.99
Fantastic Worlds.....	20.99
Fire Force.....	16.99
Fire and Ice.....	16.99
First Samurai + Mega-Lo-Mania.....	19.99
Flag *.....	19.99
Flash Back *.....	19.99
Flood.....	8.99
Football Crazy.....	16.99
Football Director 2 (1 Meg).....	16.99

Formula One Grand Prix.....22.99	
Games 92-Espana.....19.99	
Ghostbusters 2.....	6.99
Ghouls and Ghosts.....	6.99
G LOC.....	16.99
Gobliins.....	16.99
Gobliins 2.....	16.99
Gods.....	16.99
Graham Gooch *.....	19.99
Graham Taylor.....	16.99
Grusome *.....	16.99
Gunship 2000 * (1 Meg).....	22.99
Guy Spy.....	19.99
Hard Drivin.....	6.99
Harlequin.....16.99	
Harpoon + Battleset 2.....	22.99
Harpoon Battleset 3.....	9.99
Harpoon Battleset 4.....	9.99
Harpoon Scenario Editor.....	13.99
Head Over Heels.....	6.99
Head to Head.....	22.99
Heart Of China (1 Meg).....	22.99
Heimdall (1 Meg).....	19.99
Hitchhikers Guide.....	7.99
Hoi.....	16.99
Hook.....	16.99
Humans.....	19.99
Ian Botham.....	19.99
IK+.....	6.99
Indy Jones - Atlantis Action *.....	19.99
Indy Jones - Atlantis Adv (1 Meg).....	24.99
Int Sports Challenge.....	19.99
Ishar.....	19.99
Ivanhoe.....	6.99
Jack Nicklaus Extra Courses.....	9.99
Jack Nicklaus Golf.....	7.99
Jack Nicklaus Unlimited Golf (1 Meg).....	19.99
Jaguar XJ220 (1 Meg).....	16.99
Jimmy Whites Snooker.....	19.99
John Madden.....	16.99
Keys of Maramon *.....	16.99
KGB*.....	20.99
Kings Quest 5 (1 Meg).....	22.99
Knightmare.....	19.99
Knights of the Sky (1 Meg) 22.99	
Laser Squad 2 *.....	16.99
Leeds United.....	17.99
Leander.....	16.99
Leathal Weapon 3.....	16.99
Leather Goddess.....	7.99
Legend.....	21.99
Legend of Kyrandia.....	23.99
Legends of Valour.....	20.99
Leisure Suit Larry 5 (1 Meg).....	22.99
Lemmings + Data Disk.....	19.99
Lemmings Construction Kit *.....	16.99
Lemmings Data Disk.....	13.99
Lemmings 2 *.....	17.99
Links.....	24.99
Lombard Rally.....	6.99
Lure of the Temptress.....	19.99
M *.....	21.99
M1 Tank Platoon.....	19.99
Magic Pockets.....	16.99
Man Utd. Europe.....	8.99
Match of the Day.....	16.99
Mcdonalds Land*.....	16.99
Mega Fortress (1 Meg).....	22.99
Mega Sports.....	19.99
Mega Traveller 1 (1Meg).....	19.99
Mega Traveller 2 (1 Meg).....	19.99
Microprose Golf.....	22.99
Microprose Soccer.....	6.99
Midnight Resistance.....	6.99
Midwinter 2 (1 Meg).....	22.99
Moonstone (1 Meg).....	19.99
New Zealand Story.....	6.99
Nigel Mansell World Champ.....	19.99
No Second Prize.....	19.99
Operation Wolf.....	6.99
Ork.....	19.99
Outrun.....	6.99
Pang.....	6.99
Paperboy 2.....	16.99
Parasol Stars.....	16.99
PGA Golf Courses.....	9.99
PGA Tour Golf+.....	19.99
Pinball Dreams.....16.99	

Pinball Fantasies.....19.99	
Piracy.....	19.99
Pool of Radiance (1 Meg).....	19.99
Pools of Darkness (1 Meg).....	21.99
Populous.....	8.99
Populous 2 *.....	22.99
Populous Challenge Disk.....	10.99
Powerdrift.....	8.99
Powermonger.....	19.99
Powermonger Data Disk 1.....	9.99
Premiere (1 Meg).....19.99	
Premier Manager.....	17.99
R-Type.....	6.99
Railroad Tycoon (1 Meg).....	22.99
Rainbow Collection.....	13.99
Rainbow Islands.....	6.99
Rambo 3.....	6.99
Ramparts.....	16.99
Reach for the Skies *.....	22.99
Realms (1 Meg).....	19.99
Red Zone.....	16.99
Rise of the Dragon (1 Meg).....	22.99
Risky Woods.....	16.99
Road Rash.....	19.99
Robocop.....	16.99
Robocop.....	8.99
Robocop 3.....	16.99
Robo Sport.....	19.99
Rock Star Ate My Hamster.....	4.99
Rome AD 9 *.....	16.99
R-Type 2.....	16.99
Sabre Team.....	19.99
Second Surami *.....	16.99
Secret of Monkey Island (1 Meg).....	16.99
Secret Monkey Island 2.....24.99	
Sensible Soccer 92/93.16.99	
Shadow Lands.....19.99	
Shadow of Beast 3.....	19.99
Shadow Worlds.....	17.99
Shadow Warriors.....	6.99
Shinobi.....	8.99
Shoot Em Up Con Kit.....	8.99
Shuttle.....19.99	
Silent Service 2 (1 Meg).....	22.99
Silkworm.....	8.99
Silly Putty.....	16.99
Sim City+Populous.....	19.99
Sim Earth *.....	22.99
Space Crusade.....	16.99
Special Forces.....	22.99
Strategy Masters *.....	20.99
Street Fighter 2.....19.99	
Strider.....	6.99
Striker (1 Meg).....	16.99
Strip Poker 2 + Data.....	6.99
Stunt Car Racer.....	6.99
Super Fighter.....	17.99
Super Fighters.....	17.99
Superfrog *.....	17.99
Super Hang On.....	6.99
Super Tetris.....	16.99
Switchblade.....	6.99
Switchblade 2.....	8.99
Team Yankee.....	19.99
Team Yankee 2 (1 Meg).....	19.99
The Immortal (1 Meg).....	8.99
The Manager.....19.99	
Their Finest Hour (1 Meg).....	19.99
Thunderhawk.....	19.99
Titus The Fox.....	16.99
Top League.....	20.99
Troddlers.....	16.99
Turbo Challenge.....	8.99
Turbo Challenge 2.....	16.99
Turbo Challenge 3.....	16.99
Turbo Outrun.....	6.99
Turrican 2.....	9.99
TV Sports Baseball *.....	19.99
Ultima 6 (1 Meg).....	19.99
Universal Monsters*.....	17.99
Utopia + Data Disk.....	19.99
Wing Commander (1 Meg).....	22.99
Wizball.....	6.99
Wizkid.....	16.99
WWF 2.....	17.99
Zool.....	16.99

SPECIAL OFFERS

Kick Off 2 Final Whistle.....	7.99
Kick Off 2 Giants of Europe.....	7.99
Kick Off 2 Return to Europe.....	7.99
Kick Off 2 Winning Tactics.....	5.99
Kick Off 2 1Meg.....	9.99
Kick Off 2 i Meg.....	7.99
Shadow Of Beast 2.....	9.99
The Kristal.....	9.99
Wild Wheels.....	4.99
Mercenary 3.....	9.99
Dizzy Panic.....	6.99
Popeye 2.....	5.99
Thunderstrike.....	6.99
Seymour Goes to Hollywood.....	6.99

EDUCATIONAL

The Three Bears (5-10).....	13.99
Magic Math (4-8).....	13.99
Maths Mania (8-12).....	13.99
Junior Typist (5-10).....	10.99
Better Spelling (8-14).....	13.99
Better Maths (12-16).....	13.99
Fun School 2 (6-8).....	6.99
Fun School 2 (+8).....	6.99
Fun School 2 (U6).....	6.99
Fun School 2 (5-7).....	16.99
Fun School 3 (+7).....	16.99
Fun School 3 (U5).....	16.99
Fun School 4 (5-7).....	16.99
Fun School 4 (7-11).....	16.99
Fun School 4 (U5).....	16.99

JUNIOR ADVENTURE

A Christmas Carol.....	
Scroge (+8).....	13.99
Robin Hood (+8).....	13.99
The Wind in the Willows (+6).....	13.99
The Wizard of Oz (+6).....	13.99

BLANK DISKS

TDK or Makell - Boxed	
10 x 3.5" - £7.99	
20 x 3.5" - £14.50	
50 x 3.5" - £35.00	
Precision - Boxed	
10 x 3.5" - £6.45	
20 x 3.5" - £11.99	
50 x 3.5" - £26.00	
Unbranded - Loose	
10 x 3.5" - £5.99	
20 x 3.5" - £10.99	
50 x 3.5" - £23.99	
100 x 3.5" - £44.99	
Recycled - Loose	
10 x 3.5" - £4.50	
20 x 3.5" - 8.50	
50 x 3.5" - 16.00	
100 x 3.5" - 30.00	

JOYSTICKS

Quick Joy Top Star.....	17.99
Quick Joy 2 Turbo.....	10.99
Quick Joy Jet Fighter.....	10.99
Fighter.....	5.99
Cheetah 125+.....	7.99

To the Sun reader, astronomy is what Russell Grant does. To the layman, it's a world of semi-religious terms like Right Ascension. In truth, astronomy is as simple as turning on your Amiga and looking out of the window.

Neil Jackson does a bit of star gazing...

Starlight excess

AMIGA FORMAT

156

FEBRUARY 1993

ONE THING THAT astronomers hate about Britain, it's the weather. Not because they get wet, but because a sky of clouds makes viewing stars a bit tough. For first-time astronomers, there's another problem – knowing what you're looking for. It's easy to get disorientated when looking at a sprinkling of stars hundreds of light years away, especially if you don't know a binary from a black hole.

Famous names like Galileo, Herschel and Copernicus learned their astronomy the hard way, with pen and paper, endless calculations and a lot of eye-strain, but nowadays we don't have to go through that.

With an astronomy program you can do all the leg-work of finding stars without going out in the cold. Once you've located a star with your computer, you can read the coordinates from the screen and set up your telescope to match. Even if all you have is a pair of binoculars and a magnetic compass, an astronomy package can still make sky-searching easier.

There's an entire universe of bizarre celestial objects, man-made lumps in space, and Lord knows what else up there. The trouble is, it's never there when you want it and it's usually tiny when you eventually find it.

A good astronomy program lets you zoom in close to see the details, or experiment with different viewpoints. Really good programs (like those on review here) are supplied with digitised photographs taken by professional astronomers. These stunning full-colour views can make the whole topic seem more vibrant and exciting. And the more you play with your model universe, the more you'll learn from the real one – without getting wet or cold.

In essence, *Distant Suns* is similar to *Voyager*. It does many of the same jobs like tracking planets, updating the sky in real time, finding specific stars or deep-sky objects. The major difference is the way in which *Distant Suns* goes about its work. If you're running it from a single-floppy Amiga, you'll meet *Distant Suns'* clumsiness in the first few moments.

Although the program disk comes with its own Workbench which means you don't have

VOYAGER £69.95
by Carina Software

DISTANT SUNS
£69.95
by Virtual Reality Labs

Both are available
from HB Marketing
0753 686000



This is just one of *Voyager's* many full-screen HAM views. As with *Distant Suns*, you can purchase more of these direct from the makers in the USA or create your own.

to find yours, it doesn't auto-run, which is a bit daft (*Voyager* makes no pretence – it doesn't come with any Workbench, so you have to use your own!). Worse, *Distant Suns* takes ages to load, and at one point it asks you to swap the disks – using a black box, with black text, on a black background! Very helpful – not!

Assuming you make it past this oversight (which just looks like a black-screen crash), *Distant Suns* goes on to ask for no fewer than 10 disk swaps. Nightmare! I wouldn't want to have to do that in the dark. To get the most out of *Distant Suns* (and avoid terminal insanity) you really need at least an external disk. Both

programs improve several hundred percent when installed on hard drive.

Another bug-ette occurs when you set up your location and current time. You type this data into a separate dialogue box which opens up on the main screen. This is fine if the system clock is stopped – if it isn't, the dialogue box resets to the system clock and location, usually just before you finish the last couple of entries. A small point, but an example of the way some things are done in *Distant Suns*.

Distant Suns does have features which aren't in *Voyager*, but there are only three worth noting. One is *Distant Suns'* facility to

DISTANT SUNS



At first glance, *Distant Suns* is a bit daunting, because all the simple functions are tucked away in hidden menus. It's also slightly slower to update.



Distant Suns' most impressive feature is its What's Up? mode. This tells you all the important things you're going to see in the real sky tonight.

VOYAGER



No matter where you are on Earth, you can pinpoint your viewing location with a couple of clicks. And you can even learn a bit about the Earth too!



Lunatics beware! With *Voyager's* moon map you can spot individual craters and find out where the astronauts landed. A full moon indeed!

create animations which you can save as ANIM files, another is its AREXX commands. Combine the two and you can make some impressive standalone animations automatically, but it requires some time to master.

A more useful feature is the 'What's Up?' mode which displays all the major movements in your bit of sky according to the current date, time and location. It's quick and useful and it's great if you're intent on spotting something 'special' and you need to know the time it happens. It also gives you a few days' advance warning of meteor showers.

Some of the other claimed features don't seem to be doing anything at all. The twinkle option is supposed to simulate the interference caused by the Earth's atmosphere, but this has no noticeable effect, despite much twiddling with the monitor.

Another mode, the Flashcard, is supposed to give you quick star-spotting tests. In theory, it chooses a random constellation viewed from Earth and you guess what it is. In practice, it just doesn't work properly and it just keeps displaying the same bit of sky, and then crashes. Further investigations seem to produce no solutions, but the crash hasn't happened again, just to be awkward.

On the whole, *Distant Suns* is a bit disappointing compared to *Voyager*. It does have redeeming features, especially the animation capability, but it doesn't really have the air of quality that *Voyager* possesses. It may be more useful than *Voyager* if you're a die-hard serious astronomer, partly because its notation will be more familiar to pros than beginners, and partly because it has a red-only display mode which doesn't ruin your night-vision.

SKY VERSUS SKY – THE PROGRAMS COMPARED

Both programs feature a bewildering array of options, and both look similar when it comes to the stars on the screen. But the two programs have several differences which could change your buying decision. Here's how they stack up...

	Voyager V1.1	Distant Suns V4.1
SYSTEM SET-UP		
Minimum RAM	1 Mb (chip)	1 Mb (chip)
Number of disks supplied	3	2
Runs from floppies	Yes	yes
	(Workbench reqd)	(Workbench inc)
Hard-drive installable	yes	yes
Multi-tasks OK	yes	yes
User-definable startup	yes	yes
Load/save settings	yes	yes
Demo settings included	yes (38)	yes (3)
TIME CONTROLS		
Auto-advance time	yes	yes
Forwards and backwards time	yes	yes
Variable time step	yes	yes
LOCATION CONTROLS		
User-definable location	yes	yes
Pre-defined city locations	yes	no
Pick from globe	yes	no
Pick planet to view from	yes	yes (not moon)
Outer space viewpoints possible	yes	yes
VIEW CONTROLS		
Variable field of view (zoom)	yes	yes
Star atlas/planetarium view	yes	yes
Local horizon view	yes	yes
Full sky/Mercator view	yes	yes
Variable brightness/magnitude range	yes	yes
Town/country/city sky brightness levels	no	yes
Twilight sky modes	yes (3 shades)	yes (16 shades)
Star trails	yes	yes
Twinkle mode	no	yes
Dim control panel	no	yes
Lock view to object	yes	yes
Show precession (planet-wobble)	yes	yes
VIEW OPTIONS		
Planets	11	11
Quick-search major stars	17	1
Quick-search constellations	88	89
Quick-search asterisms		
(familiar star-clusters)	24	10
Comets	16	11
Asteroids	16	3
Spacecraft	5	none
Deep-sky objects		
(galaxies, nebulae, etc)	yes	yes
Constellation outlines	yes	yes
Mythical constellation creatures	yes	no
Sky grid	yes	yes
User-definable object orbits	yes	yes
Earth's shadow	yes	yes
Custom horizon line	yes	yes
Milky Way outline	yes	no
EXTRA FEATURES		
Identify random star mode	no	yes
'What's up tonight?' mode	no	yes
Conjunction search	yes	no
Planet gallery	yes	no
Moon map	yes	no
Day/night map	yes	no
Full-screen planet/star pictures	22	2
Save screen as IFF	yes	yes
Save animations as ANIM file	no	yes

If you intend to create animated sequences which can be played separately, *Distant Suns* is the only choice. However, *Voyager* has several interesting sub-screens which provide more detail on the common stellar objects than *Distant Suns*. This, combined with the easier control interface and more accessible educational bits make *Voyager* the best choice for a casual, amateur or beginner astronomer – and that's most of us!

Distant Suns is a bit more techie, and assumes a degree of knowledge and patience which only more advanced astronomers may possess. *Distant Suns* is better-suited to 'field-work' with a telescope, because it can give a quick run-down on objects which are in the sky at any particular time and date. *Voyager* can also predict interesting events, but the only way to find what's available for viewing is to run a few time-lapse frames and study the screens – a bit more time-consuming.

Overall, *Voyager* is the most recommended program of the two because it provides the most options and, more importantly, they're presented in a much more understandable way than *Distant Suns*.

Voyager does everything with a certain flair and lack of complexity that *Distant Suns* just doesn't seem to have.

Distant Suns

SPEED	●●●●
Slightly slower than <i>Voyager</i> . <i>Distant Suns'</i> update rate isn't excessively slow, just erratic.	
DOCUMENTATION	●●
Too much waffle, most of which doesn't really demonstrate what you can do with the program.	
ACCESSIBILITY	●●
Unwelcoming first screen sets the tone. The program is tough to get your head round.	
FEATURES	●●●●
Not as many features as <i>Voyager</i> , but <i>Distant Suns</i> can build and save animation files.	
VALUE	●●●●
Useful and interesting, but only worth investing in if you specifically want to make ANIM files.	

Verdict **76%**

Voyager

SPEED	●●●●
Good enough on an A500, <i>Voyager</i> literally flies along on an Amiga 1200.	
DOCUMENTATION	●●●●●
Walk-throughs and reference sections make this an ideal manual for beginners and pros.	
ACCESSIBILITY	●●●●●
Obviously there are techie bits, but <i>Voyager</i> is fairly intuitive, even to first-time astronomers.	
FEATURES	●●●●●
Bundles more options than anything else at this price. Enough to keep you involved for hours.	
VALUE	●●●●●
A bit pricey, but <i>Voyager</i> is worth it. Consider it an investment into your kids' education.	

AMIGA GOLD **92%**



This is one of the two full-screen views that come with *Distant Suns*. If you want any more, you have to buy them separately.



On December 9 1992 there was a total eclipse of the moon. Viewed from the surface of the moon of course it would have appeared as a solar eclipse.

**DUE TO CONTINUED DOLLAR/POUND EXCHANGE RATE PROBLEMS
COMMODORE ARE TO INCREASE ALL PRODUCT PRICES AS OF THE 01/01/93**



CUSTOMER CHARTER

INDI Direct Mail is original and very exciting. Before you buy mail order you must first be confident that you will receive the product you've ordered and that the supplier will still be there in the future, should you need them.

A mail order purchase from INDI is a safe and secure decision, and here's why.

INDI is a wholly owned subsidiary of a public company now in its tenth year of trading and specialising in the supply of computer products.

With a turnover approaching £30 million per annum, we have the resources and the purchasing power to offer you the best deals, deliver them next day nationwide and always be around when you need us.

SALES AND SUPPORT

The INDI sales team have been trained to take your order with the utmost care and efficiency. All stock offered for sale is held in stock, centrally at our group warehouse complex and is available for next day delivery, direct to your home or business. If at any time we are out of stock your money will not be banked until the product is available (a point worth checking should you feel tempted to purchase elsewhere).

General information regarding product is available from our sales team, however technical support is always on hand should you need assistance.

All prices quoted are inclusive of VAT.

INDI TELESales

Tel 0606 43860 Fax 0606 43825

DESPATCH

All orders received by 6pm Monday to Friday are despatched that day for next day delivery using our national carrier — Securicor. (UK Mainland only). Saturday deliveries are available at a small surcharge. If you are out when we deliver a card will be left at your home giving you a contact telephone number to arrange a convenient re-delivery.

Delivery queries can be resolved immediately using our on-line computer.

All orders are despatched on a next working day delivery basis. Cheque orders are despatched immediately on cheque clearance, usually 5 working days from receipt. A delivery charge of £5.00 is made per item unless otherwise stated.

**WE ALSO ACCEPT B.F.P.O. ORDERS (DUTY FREE).
CARRIAGE CHARGED AT UK POSTAL RATES.**

AMIGA A600 THE WILD, THE WEIRD AND THE WICKED PACK

12 MONTHS AT HOME SERVICE



Once again Commodore have put together a winning theme pack to complement the already popular Amiga A600. The Wild, the Weird and the Wicked Pack is an ideal starter pack containing a considered mix of software making the most of the Amiga's amazing capabilities.

To make this pack a perfect gift INDI have added a further four award winning games and a staggering list of valuable extras at amazing prices.

PACK AS STANDARD CONTAINS

- Amiga A600 single drive
- Built in TV Modulator
- 1Mb memory
- Push Over • Silly Putty
- Grand Prix • Deluxe Paint III
- Mouse and Manuals

INDI VALUE ADDED

- Micro Switch Joystick
- Lockable Disk Box
- Disk Wallet
- 10 Blank Disks
- Kick off 2 Pipemania
- Space Ace Populous
- Zapsac Carry Case
- Zappo T-shirt

**TO AVOID DISAPPOINTMENT
PLEASE PHONE FOR
LATEST INDI OFFERS
ON ANY PRODUCT YOU
WISH TO PURCHASE**

**STERLING
DEVALUATION
PHONE TODAY
DONT DELAY**

INDI PRICE

£ **STERLING
DEVALUATION
PHONE TODAY
DONT DELAY** 19

Panasonic Quiet Colour Printing

We researched the colour printer market in great depth to find a colour printer good enough to cope with Amiga's powerful graphic output, yet at an affordable price.

We found the perfect printer in the Panasonic KX-P2123 quiet printer

We then considered that if you were going to buy a Panasonic printer, you would probably need a quality word processing package to use with it. We found that too, in 'Wordworth', yet at a retail price of £129.99 we thought that might be a little too expensive on top of your printer purchase! So together with Panasonic we decided to give a copy of 'Wordworth' free with every Panasonic printer. How's that for added value?

Panasonic KX-P2123



INDI PRICE

£ **239.99**

The new high performance Panasonic KX-P2123 24 pin. Quiet colour printer offers leading edge quiet printing technology at an affordable price.

- **Fast Printing Speeds** 192 CPS draft, 64 CPS LQ and 32 CP SLQ.
- **Colour Printing** 7 colour palette (blue, red, green, yellow, violet, magenta and black)
- **QuietPrinting** Super quiet 43.5-46kBA sound level (most matrix printers are typically in excess of 60dBA)
- **7 Resident Fonts** Over 152,000 type styles using Super LQ, Courier Prestige, Bold PS, Roman, Script and Sans Serif Fonts
- **24 PIN Diamond Printhead** High performance and high quality output
- **1 Year Warranty** for total peace of mind.

* WORDSWORTH COMPLETELY FREE!

WITH PANASONIC QUIET PRINTERS The writers choice. The ultimate word processor for AMIGA computers. NORMAL RRP £129.99 inc. vat

AMIGA A1200

ALL NEW
32-BIT
AMIGA



The latest, the ultimate, the best home computer available. 16.8 million colours, superfast processor, superb stereo sound, lightning speed — the all new Amiga 1200 has them all. Marvel at the ease with which the Amiga 1200 and its amazing 32-bit processing power devours the most demanding software. At this price the A1200 has no equal — forget the rest, it's definitely the best!

1200 STANDARD FEATURES

- 68020 Processor
- 2Mb Chip RAM
- AA Chipset
- Alpha-numeric keypad
- PCMCIA Slot
- 3.5" Internal Floppy
- Built-in TV modulator
- Free 12 Months At-Home Maintenance

INDI VALUE ADDED

- 3 Superb Games
- International Sports Challenge
- The Cool Croc
- Paratroid 90

INDI PRICE

£ **STERLING
DEVALUATION
PHONE TODAY
DONT DELAY**

EVEN THOUGH INDI HOLD CONSIDERABLE STOCKS OF PRODUCTS, IT IS INEVITABLE THAT OUR PRICES WILL EVENTUALLY BE AFFECTED.

AMIGA CDTV THE MULTIMEDIA COMPUTER TOTAL



HOME ENTERTAINMENT SYSTEM



- AUDIO**
Blues Brothers (CD Audio) £12.99
- AMIGA**
Pipemania, Populous, Kickoff 2, Space Ace £122.52
- MULTI MEDIA**
Lemmings CDTV £24.99

The problem with any new product is that it always takes time for everyone to realise its full potential. CDTV is no exception and in our opinion everything we have read does a pretty poor job of explaining just what CDTV can do and why it is so exciting.

THE INDI GUIDE TO CDTV

IT'S A CD PLAYER - Yes, it will play all your Primal Scream, Pavarotti, Pink Floyd and any other CD you care to mention in superb high quality stereo, with remote infra red control.

IT'S AN AMIGA - Plug in the keyboard, switch on the external disk drive and the colossal range of inexpensive Amiga software can be used on your CDTV.

IT'S A MULTIMEDIA SYSTEM - Just imagine, stereo sound, images and text all on screen. It asks

a question, you respond, it responds - truly interactive. Each CD disc holds hundreds of megabytes of data with instant optical access. The whole of Hutchinson's Encyclopedia fits onto 1 disc. This interactive system is a unique aid for Education, Business or Leisure. The future is here!

PACK CONTENTS AS STANDARD

- Amiga CDTV Player
- CDTV keyboard
- CDTV 1411 3.5" Disc Drive
- CDTV Infra red remote controller
- CDTV wired mouse
- CDTV Welcome Disc
- Manuals
- Fred Fish CDTV

INDI VALUE ADDED

- Lemmings CDTV (£34.99)
- Blues Brothers (£12.99)
- Pipemania, Populous, Kickoff 2, Space Ace (£122.52)

CDTV CONNECTS DIRECTLY TO YOUR TV SET



AFTER SALES AND SPECIALIST SERVICE

All products are guaranteed for 12 months. Some products carry a 12 month at home service/repair guarantee (where indicated). In the unlikely event that any product purchased from INDI arrives at your home faulty, we will collect from your home and replace the product completely free of charge. If you own an AMIGA 1500 or 3000 and would like to expand its hard disk or memory capability or add any other peripheral INDI can offer you a complete door to door configuration service together with an additional 12 months Back to INDI warranty. Why not ask for a quote?

Products advertised represent a small sample of our instock range. A complete price list is available on request.

All products purchased come with a complete list of all products available from INDI with special customer loyalty offers.

AS PART OF OUR POLICY OF CONTINUAL PRODUCT DEVELOPMENT AND REFINEMENT, WE RESERVE THE RIGHT TO CHANGE SPECIFICATIONS OF PRODUCTS ADVERTISED. PLEASE CONFIRM CURRENT SPECIFICATION AT THE TIME OF ORDERING.

PRICES ARE VALID FOR MONTH OF PUBLICATION ONLY

HOW TO ORDER

BY POST - simply fill in the coupon below.

BY PHONE - ring 0606 43860 where your call will be answered by one of our INDI sales team. After 6.00pm each day your call will be answered by answerphone. If you would like to place an order have all details at hand including Credit Card. The message will guide you through your order.

AMIGA CDTV EXTERNAL HARD DISK DRIVE

You've got the CDTV, you've got the keyboard and floppy disk drive - for a total computer solution all that's needed is an ultra-fast hard disk drive. The CDTV-HD unit boasts a massive 65Mb of hard disk storage with lightning fast access times through its SCSI interface. The unit comes complete with Workbench 1.3 and all necessary cables.



ACCESSORIES

- CDTV Starter Pack** - Includes CDTV, Remote Control, Hutchinsons, Lemmings & Welcome Disk CD's £234.82
- A570 External CD drive** for the A500 & A500+ (includes free Hutchinsons Encyclopaedia & Lemmings) £369.99
- MEGACHIP** - 1Mb ChipRAM Upgrade for CDTV £929.99
- CDTV Keyboard** (black) £44.99
- CDTV 3.5" External Floppy Drive** £119.99
- ENCORE SCSI Controller**+Internal Mount Kit £199.99
- CDTV Internal Genlock** £129.99
- CDTV Remote Mouse** £129.99
- SCART TV/Monitor Lead** (inc. stereo phono lead) £1526.23

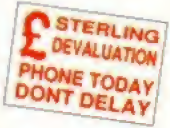
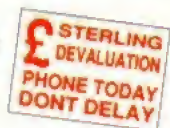

PROFESSIONAL AMIGA & PERIPHERALS

- Panasonic Colour Ribbon 6 Pack** for KX-P2180 & KX-P2123 RRP £119.99 **INDI PRICE £89.99**
- Panasonic Ribbon Pack** for KX-P2180 & KX-P2123 RRP £99.99 **INDI PRICE £69.99**
- Panasonic Sheet Feeder** for KX-P2123 & KX-P2180 printers. RRP £89.99 **INDI PRICE £79.99**
- KX-P2180/KX-P2123 Deluxe Accessory Pack** Contains:
 - Automatic Sheet Feeder
 - 2 x Black Ribbons
 - 2 x Colour Ribbons
 - 1 x Dust Cover
 - 2 Piece Printer Stand
 RRP £169.99 **INDI PRICE £132.99**
- ZAPPO FLOPPY** - External 3.5" drive suitable for all Amigas £44.99
- ZAPPO 601NC** - 512K Amiga 600 RAM upgrade (no clock) £29.99
- ZAPPO 601C** - 1Mb Amiga 600 RAM upgrade (with clock) £49.99

- MULTISTART II ROM SHARER** + 1.3 ROM - Use both 1.3 & 2.04 Kickstart ROMs £44.99
- ROCTEC GENLOCK** - Cost effective video overlay for all Amigas £69.99
- SUPRA RX 2Mb** - External 2Mb RAM upgrade for A500/500+. Can be increased up to 8Mb £119.99
- 2Mb SMARTCARD** - Credit card style RAM card utilising A600/A1200 PCMCIA SLOT £129.99
- 4Mb SMARTCARD** - For A600/A1200, maximum RAM with a lifetime guarantee! £199.99
- REPLACEMENT POWER SUPPLY** - for the Amiga A500/A600/A1200 £24.99
- AMIGA 3000** - With 2Mb RAM, 120Mb Hard Disk, Publishers Choice, Amiga Vision £1526.23

- AMIGA 4000** - With 6Mb RAM, 120Mb Hard Disk & Amiga Vision £2348.82
- COMMODORE 1960** - 14" High resolution monitor for use with A3000 & A4000 £369.99
- OPAL VISION 24-BIT GRAPHIC SYSTEM** - For the Amiga 1500/2000/3000/4000. £699.99
- A1500** (Amiga Vision worth £99.00 Free) £469.99
- A1500 + 1084ST + PANASONIC KXP2123 PRINTER** (+ Amiga Vision & Wordworth worth £228.99 Free) £929.99
- A1500 + 52Mb SCSI + 1084ST + KXP2123** (+ Amiga Vision & Wordworth worth £228.99 Free) £1159.99

SEND YOUR ORDER TO:
INDI DIRECT MAIL
FIRST FLOOR OFFICES,
85 WITTON STREET,
NORTHWICH
CHESHIRE CW9 5DW

AF0193

Please send.....
 Price + Delivery

I enclose cheque/PO for £.....
 or charge my Access/Visa No.

.....
 Expiry date /
 Signature
 Send to Name.....
 Address

 Daytime Tel.....
 Postcode

TEL: 0606 43860 • FAX: 0606 43825

ACTION

THE WORLD'S CARTRIDGE IS

NOW WITH A MASSIVE
IN ROM OFFERING
MK III

JUST LOOK AT THE UNMATCHED RANGE OF FEATURES

● SAVE THE ENTIRE PROGRAM IN MEMORY TO DISK

Special compacting techniques enable up to 3 programs to fit on one disk. Now saves directly to disk as Amiga Dos - reloads independently of the cartridge - even transfer to hard drive! Works with up to 2 Megs of Ram - even 1 Meg Chip Mem (Fatter Agnus).

● SUPER POWERFUL TRAINER MODE

now with DEEP trainer. Even better than before - allows you to generate more or even infinite lives, fuel, ammo.

Perfect as a Trainer Mode to get you past that "impossible" level. Easy to use.

● IMPROVED SPRITE EDITOR

The full Sprite Editor allows you to view/modify the whole sprite set including any "attached" sprites. PLUS A RANGE OF IMPROVED FEATURES.

● VIRUS DETECTION

Comprehensive virus detection and removal features to protect your software investment. Works with all presently known viruses.

● BURST NIBBLER.

Now this super disk copier program is built into Action Replay Mk III. Just imagine a superfast, efficient disk copier program at the press of a key - no more waiting.

● SAVE PICTURES AND MUSIC TO DISK

Pictures and sound samples can be saved to disk. Files are saved directly in IFF format suitable for use with all the major graphic and music packages. Samples are displayed as screen waveform.

● PAL or NTSC MODES SELECTABLE

Useful for removing ugly borders when using NTSC software. (Works only with newer Agnus chips).

● SLOW MOTION MODE

Now you can slow down the action to your own pace. Easily adjustable from full speed to 20% speed. Ideal to help you through the tricky parts!

● MANY MORE INSTANT CLI COMMANDS

like Rename, Relabel, Copy, etc.

● RESTART THE PROGRAM

Simply press any key and the program will continue where you left off.

● FULL STATUS REPORTING

At the press of a key now you can view the Machine Status, including Fast Ram, Chip Ram, RamDisk, Drive Status, etc.

● POWERFUL PICTURE EDITOR

Now you can manipulate and search for screens throughout memory. Over 50 commands to edit the picture plus unique on screen status "overlay" shows all the information you could ever need to work on screens. No other product comes close to offering such dynamic screen handling of frozen programs!!

● JOYSTICK HANDLER

allows the user to select Joystick instead of Keypresses - very useful for many keyboard programs.

● MUSIC SOUND TRACKER

With Sound Tracker you can find the complete music in programs, demos, etc. and save them to disk. Saves in format suitable for most track player programs. Works with loads of programs!!

● AUTOFIRE MANAGER

From the Action Replay III preference screen you can now set up autofire from 0 to 100%. Just imagine continuous fire power? Joystick 1 and 2 are set separately for that extra advantage!

● IMPROVED RAM EXPANSION SUPPORT.

Now many more external Ram Expansions will work with all Action Replay III commands.

● DOS COMMANDS

Now you have a selection of DOS commands available at all times - DIR, FORMAT, COPY, DEVICE, etc.

● FILE REQUESTOR

if you enter a command without a filename, then a file requestor is displayed.

● DISK COPY

Disk Copy at the press of a button - faster than Dos Copy. No need to load Workbench - available at all times.

● BOOT SELECTOR

Either DF0 or DF1 can be selected as the boot drive when working with Amiga Dos disks. Very useful to be able to boot from your external drive.

● PLUS IMPROVED DEBUGGER COMMANDS

including Mem Watch Points and Trace.

● DISKCODER

With the new "Diskcoder" option you can now 'tag' your disks with a unique code that will prevent the disk from being loaded by anyone else. 'Tagged' disks will only reload when you enter the code. Very useful for security.

DATTEL
Electronics
LIMITED

HOW TO GET YOUR ORDER FAST!

TELEPHONE [24Hrs] **0782 744707** CREDIT CARD ORDERS
ORDERS NORMALLY DISPATCHED WITHIN 48 Hrs. ALL CHEQUES/POSTAL ORDERS MADE PAYABLE TO...



DATEL ELECTRONICS



GOVAN ROAD, FENTON INDUSTRIAL ESTATE, FENTON, STOKE-ON-TRENT,
ST4 2RS, ENGLAND. FAX 0782 744292 TECHNICAL/CUSTOMER SERVICE 0782 744324

DATEL LONDON SHOW



222, TOTTENHAM COURT ROAD
LONDON, W1. TEL: 071 58064

ON REPLAY

**MOST POWERFUL FREEZER-UTILITY
NOW EVEN BETTER!!**

**VE 256K OPERATING SYSTEM
A WHOLE NEW RANGE OF
I FEATURES**

STILL ONLY

£59.99

**AMIGA A500/500+
FOR 1500/2000 VERSION £69.99**

**AMIGA ACTION REPLAY SIMPLY PLUGS INTO THE
EXPANSION PORT OF YOUR AMIGA AND GIVES YOU THE
POWER TO FREEZE MOST ANY PROGRAM**

NEW

SET MAP -

allows you to Load/Save/Edit a Keymap.

● **PREFERENCES**

Action Replay III now has screen colour preferences with menu setup. Customise your screens to suit your taste. Very simple to use.

NEW

IMPROVED PRINTER SUPPORT -

including compressed/small character command.

● **DISK MONITOR**

Invaluable disk monitor - displays disk information in easy to understand format. Full modify/save options.

**PLUS A MACHINE CODE FREEZER MONITOR WITH EVEN MORE
POWER!!**

MORE FEATURES INCLUDING 80 COLUMN DISPLAY AND 2 WAY SCROLLING...

- Full M68000 Assembler/Disassembler
- Full screen editor
- Load/Save block
- Write String to memory
- Jump to specific address
- Show Ram as text
- Show frozen picture
- Play resident sample
- Show and edit all CPU registers and flag
- Calculator
- Help command
- Full search feature
- Unique Custom Chip Editor allows you to see and modify all chip registers - even write only registers!
- Notepad
- Disk handling - show actual track, Disk Sync. pattern etc.
- Dynamic Breakpoint handling
- Show memory as HEX, ASCII, Assembler, Decimal
- Copper Assemble/Disassemble - now with suffix names

**REMEMBER AT ALL TIMES YOU ARE INTERROGATING THE PROGRAM IN IT'S
"FROZEN" STATE WITH ALL MEMORY AND REGISTERS INTACT
- INVALUABLE FOR DE-BUGGING OR JUST THE INQUISITIVE!**

WARNING 1988 COPYRIGHT ACT WARNING

Datel Electronics Ltd. neither condones or authorises the use of its products for the reproduction of copyright material. The backup facilities of this product are designed to reproduce only software such as Public Domain material, the users own programs or software where permission to make backups has been clearly given. It is illegal to make copies, even for your own use, of copyright material, without the clear permission of the copyright owner, or the licensee thereof.



NOW A FULL COLOUR HANDY SCANNER FOR YOUR AMIGA

AT AN UNBEATABLE PRICE!!

FOR ONLY
£199.99

- The NEW Datel Colour Scanner uses the Mustek 8 colour grey scale head to produce 4096 colour images.
- Several modes of operation are available to give 8, 16 or 32 different colour and Ham images as well as 16 grey scales.
- Scan update direct to the screen with direct scrolling and positioning of the scanned image.
- Full colour palette control with Gamma correction.
- Save IFF or Raw files of screen or buffer.

- Runs in 640 x 256 or 320 x 256 screen display.
- Unit plugs into expansion port of Amiga and does not require external power unit..

HIGH RESOLUTION BLACK & WHITE HANDY SCANNER AT AN EVEN LOWER PRICE!

- NEW** IFF Buffer Save 1600 x 1024 pixels, dual buffer, scan matching & view Buffer.
- Unmatched edit/capture facilities & keyboard control not offered by other scanners at this special price.
- NEW** Full keyboard control of most functions.
- An easy to handle Handy Scanner featuring 105 mm scanning width & 400 dpi resolution enables you to scan graphics/text into your Amiga.

- NEW** Includes hard disk transfer to run under Workbench.
- Adjustable switches for brightness/contrast levels.
- NEW** Full sizing menu of scan area.
- Geniscan gives you the ability to scan images, text or graphics & even offers 200 Dpi Dual Scan Mode.
- NEW** Screen grid overlay & configure menu to save parameters. Icon menu to select functions.

- NEW** X, Y position readout & metric sizes.
- Save images in suitable format for most leading packages including PHOTON PAINT, DELUXE PAINT, etc.
- NEW** View window and position control panel.
- Powerful partner for DTP that allows for cut and paste editing of images etc.

COMES WITH FREE PHOTON PAINT



NEW LOWER PRICE

NOW ONLY **£99.99**

• Package includes Handy Scanner, Interface, Power Pack and Scan Edit IV software.

GENIUS DIGITIZING TABLET

ADD A PROFESSIONAL TOUCH TO YOUR DRAWING/CAD WORK

- With the Amiga Genitizer Graphics Tablet you can streamline the operation of most graphic or CAD programs.
- The Genitizer Graphics Tablet utilises latest technology to offer up to 100 dpi resolution at the tip of a stylus.
- Complete 9" x 6" digitizing area plus super accurate stylus combine to enable fast, accurate and easy control.
- Works by "mouse emulation" so the Genitizer will work with most packages where mouse input is the usual method - Deluxe Paint, Photon Paint, CAD Packages, etc.
- Supplied with a template for Deluxe Paint.
- Full easy to follow instructions.
- This is the input method used on professional systems - now you can add a new dimension to graphics/CAD.
- Fast input of drawing by "tracing" is made easy - plus "absolute reference" means you can move around the screen many times faster than by a mouse.
- The Genitizer fits in the serial port of your Amiga 500/1000/2000 and "co-exists" with mouse.
- Unlike a mouse, the Tablet gives absolute co-ordinates so that tracking and menu selections are possible from the tablet face.

- A pressure sensitive switch built into the stylus tip activates the Tablet overriding the normal mouse input. When you are not using the Tablet, you have normal mouse control.
- Complete system - Graphics Digitizer Tablet, Stylus, Deluxe Paint Template, Power Adaptor, Test Software, Interface Unit, plus Driver Program - no more to buy!

NOW ONLY
£129.99

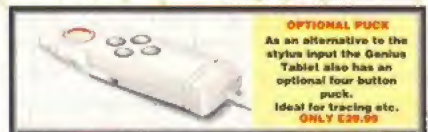

OPTIONAL PUCK
As an alternative to the stylus input the Genitizer Tablet also has an optional four button puck. Ideal for tracing etc. **ONLY £29.99**

GOLDEN IMAGE OPTICAL REPLACEMENT MOUSE

... NOW A TRUE OPTICAL MOUSE! FOR THE AMIGA

- YES A FULL FEATURE OPTICAL MOUSE FOR YOUR AMIGA - THAT MEANS NO MOVING PARTS!
- Incorporating full optical tracking and counting - no ball so no problems with clogging, slipping, etc. High count output for very fine movement.
- Two button microswitch action.
- Comes complete with special "Optical Pad".
- Superbly styled - supersmooth shape moulded to fit the hand.
- Comes complete with moulded 9 pin connector. No more to buy!

COMPLETE ONLY **£39.99**



GENIUS MOUSE

- High quality direct replacement for mouse on all Amigas.
- Teflon glides for smoother movement.
- Rubber coated ball for minimum slip.
- Optical system counting - 500/mm.

COMPLETE WITH ALL ACCESSORIES
ONLY **£19.99**



NEW LOWER PRICE



HOW TO GET YOUR ORDER FAST!

TELEPHONE (24Hrs) **0782 744707** CREDIT CARD ORDERS
ORDERS NORMALLY DISPATCHED WITHIN 48 Hrs. ALL CHEQUES/POSTAL ORDERS MADE PAYABLE TO...

DATEL ELECTRONICS

GOVAN ROAD, FENTON INDUSTRIAL ESTATE, FENTON, STOKE-ON-TRENT,
ST4 2RS, ENGLAND. FAX 0782 744292 TECHNICAL/CUSTOMER SERVICE 0782 744324

DATEL LONDON SHOP



222, TOTTENHAM COURT RD,
LONDON, W1. TEL: 071 5806460

FED UP WAITING?

JUST ADD £2.00 TO YOUR TOTAL ORDER FOR A GUARANTEED * NEXT DAY DELIVERY TO YOUR DOOR
(* ORDERS MUST BE PLACED BEFORE 3.30pm excluding weekends)



COMPUTER MATES (UK) LTD.

All disks can be supplied formatted and ready to use for any IBM machines for as little as 4p per disk.

CHEQUES/POSTAL ORDERS TO:
COMPUTER MATES (UK) LTD.
PINWOOD STUDIOS, IVER HEATH
BUCKS, SL0 0NH
TEL: 0753 553535 (3 lines) FAX: 0753 553530

ALL PRICES INCLUDE V.A.T. & DELIVERY

MITSUBISHI BRANDED DISKS			
BOX/10	5.25" (360K)	5.25" (1.6 Meg)	3.5" (1 MEG)
	5.00	7.00	7.00
			3.5" 2 MEG(1.44)
			12.00

NEW JUST APPOINTED DEALER

GOLD MASTER BRANDED 2 FOR 1 LIFE TIME WARRANTY		
	1 MEG MF-2DD	2 MEG MF-2HD
1 BOX	6.50	13.00
2 - 5 BOXES	6.00	12.50
6 - 10 BOXES	5.50	12.00

DATA CARTRIDGES

DC300A.....	£17.05	DC6320.....	£24.00
DC300XL.....	£17.50	DC6525.....	£28.00
DC300XLP.....	£15.50	DC1000 10Mb	£16.50
DC300EXL.....	£18.70	DC1000 20Mb	£16.50
DC600A.....	£15.50	DC2000.....	£13.50
DC6150.....	£17.50	DC2080.....	£16.50
DC6250.....	£24.00	DC2120.....	£16.50

QUANTITY DISCOUNTS: PLEASE CALL OR FAX

LOOK! Great deals on Mitsubishi 3.5" Branded Disks

- 5 Boxes MF2DD (50 Disks) ..Only £26.00
 - 10 Boxes MF2DD (100 Disks) Only £50.00
 - 5 Boxes MF2HD (50 Disks) ..Only £45.00
 - 10 Boxes MF2HD (100 Disks) Only £88.00
- + 20% OFF ALL STORAGE BOXES WITH ABOVE DEALS

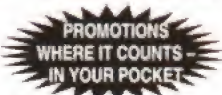

3.5" MITSUBISHI BULK MEDIA LIFE TIME WARRANTY

	DSDD	DSHD
50 Disks	£21.00	£32.50
100 Disks	£40.00	£63.50
200 Disks	£75.00	£125.50
500 Disks	£175.00	£295.50
1000 Disks	£329.00	£580.50

INCLUDES LABELS

NOTE: The above disk are based on > 55% clipping level, cheaper disks are available - please call.

5.25" BULK DISKS Packed in 25's with Envelopes, Labels, Lifetime Warranty

	48tpi	96tpi	HD
25 Disks	£8.50	£8.75	£12.00
50 Disks	£16.00	£16.25	£23.00
100 Disks	£28.00	£27.25	£36.00
1000+ PLEASE CALL			

QUICKSHOT JOYSTICKS

MULTI SYSTEM	
QS11A Turbo 2.....	£9
QS149 Intruder 1.....	£25
QS126F Maverick 1.....	£14
QS155 Aviator 1.....	£27.50
QS131 Apache 1.....	£7
QS130F Python 1.....	£9.50
QS127 Starfighter Par Remote Contro.	£36.50
NINTENDO	
QS130N Python 2.....	£9.50



Up to £3.00 OFF above Joysticks with another purchase above £15.00

MICE/TRACKERBALLS

PS2 MOUSE.....	£21.00
AMIGA/COMMODORE.....	£19.00
ATARI MOUSE.....	£19.00
ATARI/AMIGA TRACKBALL.....	£22.00
MOUSE MAT.....	£2.50
MOUSE POCKET.....	£2.50
MOUSE STAGE.....	£10.00
MOUSE MAT HARD.....	£3.50
PAPER TRIMMER.....	£5.00

STORAGE BOXES

3.5" DISK CAPACITY		5.25" DISK CAPACITY		STACKABLE BOXES	
140.....	£11.50	140.....	£9.00	Disk Name Cap	
120.....	£9.50	120.....	£8.50	3.5" Bank 80	£12.99
100.....	£7.90	100.....	£7.50	Dual Bank 5 100/180	£14.99
80.....	£7.50	50.....	£6.50	3.5 Bimby 200	£18.99
50.....	£6.50			5.25 Bimby5 200	£18.99
40.....	£6.00				

BIMBY BOXES CAN ALSO HOLD 3 2.8" VIDEO TAPES, CARTRIDGES ALL ABOVE BOXES LOCKABLE + 2 KEYS.
£2 OFF BOXES WHEN ORDERING 100 BULK DISKS OR MORE
3.5" or 5.25" 10 Cap...£1.50. 5 Cap...£1.15. 1 Cap...50p
Cardboard Disk Masters...£150/1000 or £25/100

COMPUTER MATES BRANDED DISKS

2 FOR 1 LIFE TIME WARRANTY

3.5" DISKS		COLOURED	
	DSDD	DSHD	
50 Disks	£23.00	£35.00	£27.00
100 Disks	£45.00	£69.00	£50.00
200 Disks	£85.00	£137.00	£90.00
500 Disks	£200.00	£325.00	£210.00

SPECIAL OFFERS THIS MONTH

LOOK SAVE YOUR EYES

12" or 14" COLOUR OR MONO FILTER SCREEN	
SAVE YOUR EYES.....	Only £13.99
Optical Glass Filter 14".....	£25.00
Optical Glass Filter 20".....	£35.00
12" or 14" TILT & TURN WITH HANDY KNOB	
MONITOR STAND.....	£15.95

PRINTER STANDS 5 DIFFERENT TYPES

PRINTER STAND (Feet)	
80 or 132 COLUMN.....	£8.00
IBM PRINTER LEADS.....	£5.00
JOYSTICKS ALL MACHINES P/C	

LABELS 5.25" OR 3.5" (5.25" WITH W/P)
100 £1.00, 1000 £8.00. SINGLE OR MULTICOLOUR AVAILABLE

COMPUTER DESK...£90.00



COMPUTER CHAIR...£40.00

PRICE BREAKTHROUGH ON HAND HELD VIDEO GAMES

GAMES AVAILABLE AT ONLY £12.99

P.52 Sea Battle, Grand Prix, Challenger Tank, Brain Power, Carrier, Linear Racing, Super Block, Snake, Hashblock/Eagleplan, Honey Bee, Space Fighter, Alien, Tennis Pro, Olympic Trails, Police Bust, Pacboy, Block Buster



£39.99 inc.

- SUPPLIED WITH:
- * CRYSTBALL GAME
- * BATTERIES
- * STEREO EAR PHONES

SPECIAL PACK OFFER
BUY 4 GAMES - CHOOSE ANY OTHER TITLE FREE

DUST COVERS

AMIGA/ATARI.....	£6.00
12" or 14" MONITOR.....	£6.00
80 or 132 PRINTER.....	£6.00
LAZER PRINTER.....	£6.00
84 or 102 KEYBOARD.....	£6.00
TOWER CPU.....	£6.00

DUST COVERS FOR MOST SYSTEMS - PLEASE CALL

CLEANING ACCESSORIES

MINI VACUUM CLEANER.....	£7.00	HEAD CLEANER 3.5" or 5.25".....	£2.50
MONITOR CLEANING SOLUTION.....	£3.00	ALL THE ABOVE & MORE.....	£11.00
3" CLEANING KIT.....	£3.00		

DATA SWITCH BOXES

CENTRONICS OR SERIAL.....	2 WAY.....	15.00
4 WAY.....	DATA SWITCH LEADS.....	8.00 each

COPY HOLDERS

A4 Desk Top Anglepoise.....	£15.99	Paper Clip Monitor Side.....	£4.00
A4 Anglepoise G-clamp.....	£15.99	Paper Clip Monitor Top.....	£5.00
A4 Desk Top.....	£8.00		

LOOK!

VIDEO TAPES, £180, LIFETIME WARRANTY, 3 HOURS
10 FOR £20; 50 FOR £90

RETAIL PACKED BLUE BOX DISKS

ALL BLUE BOX DISKS ARE COMPLETELY PACKAGED IN BLUE PRINTED CARDBOARD BOXES WITH LABELS. 100% GUARANTEED FOR LIFE

3.5" 720K-880K		3.5" 1.44 Meg		5.25" DISKS	
MF-2DD 10's 1 Meg		MF-2HD 10's 2 Meg		M-2D 48TPI 360K	
1 Box.....	£5.00	1 Box.....	£8.50	1 Box (10).....	£4.00
MF-2DD 30's 1 Meg		MF-2HD 30's 2 Meg		M-2DD 96TPI 720K	
1 Box (30).....	£14.00	1 Box (30).....	£21.50	1 Box (10).....	£4.75
BAMBI-2DD 1 Meg		BAMBI-2HD 2 Meg		M-2HD 1.6 Meg H/D	
25 Disks in 25 Capacity Storage Box		25 Disks in 25 Capacity Storage Box		1 Box (10).....	£5.00
1 Box.....	£14.00	1 Box.....	£21.00		

10% DISCOUNT GIVEN ON 10 BOXES OR MORE

CALL SAM OR PAT NOW! ON 0753 553535

FED UP WAITING?

ALL ORDERS ARE NORMALLY DELIVERED TO YOU WITHIN 48 HOURS



17-BIT DISK PRICES
17-BIT DISKS £1.25 EACH
FISH DISKS £1.25 EACH
SCHEME 17 DISKS £2.00
CLR DISKS £3.50 EACH
CLR 2 DISK SET £4.50
CLR 3 DISK SET £4.99
GET 1 DISK FREE WITH EVERY 10 YOU BUY!
ORDER 20+ AND GET 3 DISKS FREE!

STUCK ON THE LATEST GAMES!
 THEN GET DISK +2193 OVER 200 TIPS AND COMPLETE SOLUTIONS, FOR **HOOK, LURE OF THE TEMPTRESS, ADDAMS FAMILY ETC, THANKS TO PHOENIX FOR COMPILING IT AND SENDING IT ONLY £1.25**

AMIGA PUBLIC DOMAIN FROM 17-BIT SOFTWARE
 The UK's Leading PD library, over 4000 disks in stock, over 35000 satisfied customers worldwide
WE STOCK FISH, T-BAG, CLR, AMOS.
 STOP PRESS WE NOW STOCK FISH TO 710 !!

LAST MINUTE GAMES
 SILKWORM £6.9
 MOVIE STARS COMP £9.99
 DELTA FORCE COMP £8.99
 DEATHBRINGER £9.99
 ACTION 2 COMP £8.99
 ZOOL £17.99
 PUTTY £18.99
 LURE OF THE T/TRESS £19.99
Unbelievable Budget Full Price Software HURRY WHILE STOCKS LAST!

ALL ORDERS SENT 1ST CLASS POST! THE SAME DAY

ORDERING DISKS
 All major credit cards are taken, opening times are **MON - THURS 9am - 8pm FRI-SAT 9am - 5.30pm**
PLEASE MAKE CHEQUES AND POSTAL ORDERS PAYABLE TO 17 BIT SOFTWARE OUR ADDRESS IS (DEPT AMIGA F) 1ST Floor Offices, 2/8 Market St Wakefield WF1 1DH
 TELEPHONE - (0924) 366982
 FAX - (0924) 200943
 Foreign orders (Add 20% Minimum £1)
 Postal charges as follows
 Public Domain add 50p
 Commercial software add 75p
 Please use your Customer No. when ordering (Documents enclosed)
 Please don't forget to add the right amount

SEND US A FAX ON 0924 200943

PLEASE NOTE DISK NO'S WITH NO + ARE NOT PLUS OR A600 COMPATIBLE !!!!!

NOW TO PD ?? WANT TO KNOW MORE ??
 Then you will find our starter pack invaluable!
 - Includes Latest Update
 - Four Catalogue Disks
 - Sample Games Disk
 - £2.00 PD Voucher!
ONLY £3.95!

AM/FM ISSUE 9
 Includes Midi for beginner part 3, tutorials, music reviews, discographies, competitions, tips and loads loads more!
 Every Amiga music enthusiast should get this disk. Only £2.50 or £5.00 with the samples disk

CDPD FISH 1 TO 660 ON CD FOR ONLY £19.99 NO CDTV OWNER CAN MISS THIS !!!
ONLY £19.99

RECOMMENDED DISKS: +2012 PROTRACKER 2.2 + 2059 DIRMASTER +2085 CARD GAMES +1980 MODULE MASTER +1867 SID 2 (FILE HANDLER) + 1813 200 UTILS +1822 ELECTRO CAD £1.25 E

+CLG12	BULLDOZER BOB
+CLG11	ALL GUNS BLAZING
+CLG10	FUTURE SHOCK
+CLG09	MOTOR OUEL
+CLG08	DRAGON TILES
+CLU07	PHILO
+CLU06	SUPERSOUND 3
+CLU05	MENU MAKER
+CLU04	ALPHA GRAPH
+CLU03	TYPING TUTOR
+CLE09	WOROS + LADDERS
+CLE08	NIGHT SKY
+CLE07	(2 DISKS)..... FISHING
+CLE05	A-CHORD

All the programs above are professional in expensive products. A-Chord is a superb guitar tutor, super-sound 3 is an excellent sound processor.
ALL CLR TITLES ARE HEARTILY RECOMMENDED!
 1 DISK TITLES £3.50, 2 DISK £3.99, 3 DISK £4.50

LATEST DISKS

+2330	SLIDE CONSKIT
+2329	CED V1.51
+2328	ELEVATION GAME
+2327ABC	THE ADANIM 3MEG
+2326	INTREPID GAME
+2325AB	IRON CLADS GAME
+2324	DPAIN TEXTURES
+2323	PCQ SHELL
+2322	SOUND ENHANCER
+2321	FIGHTING WARRIORS
+2320	FREEDOM CRACK MAG
+2319	B BASE V5.5
+2318	GRINDER GRAPHICS
+2317	OUTERIM GAME
+2316	KASTLE KUMQUAT
+2315AB	ELENUM MUSIC
+2314	ALVIN AEROSOL ANIM
+2313	ASGARD CHEATS DISK
+2312	PRIZE FIGHT DEMO
+2311	ASSASSINS UTILS 3
+2310	ASSASSINS UTILS 2
+2309	ASSASSINS UTILS 1
+2308	ASSASSINS BOOT UTILS
+2307	ASSASSINS GFX UTILS
+2306	ASSASSINS CRUNCHERS
+2305	ASSASSINS COPIERS
+2304	KAOS THEORY (TECHNO)
+2303	DICKS CRUNCHERS
+2302AB	ROAD HOG ANIM
+2301	HOBBITS + SPACESHIPS
+2300	MATCHSTICK MAN GAME
+2299	UGH PREVIEW GAME
+2298	TEARAWAY THOMAS PRE
+2297	SHDADOW SLIDES
2296	FRIDAY 13TH PT 3(1M)
2296	FRIDAY 13TH PT 3 (1.5M)
+2295	XMAS ANIM
+2294	DR WHO THEME VARIOS
+2293	SHADOW SLIDES (CAR5)
+2292	WOMAN (CLI TUTOR)
+2291	JIM NAST ANIMS
+2290	ACCOUNT MASTER
+2289AB	TALISMAN GAME (2M)
+2288AB	HIGHLANDER SLIDES
+2287AB	GHOST SLIDES
+2286AB	KING CREOLE (ELIVIS)
2285	RAGING HORMONE ANIM
+2284	EIGHT SLEMX OUT ANIM
2283	RAVE ATTACK3
+2282	CLUB MIX
+2281	CULT MOVIE POSTERS
2280	IMPERIAL TUNES
+2279	ANTEP GAME
+2278AB	GLADIATORS SLIDES
+2277	WHOM 3 (STAR TREK INFO)
+2276	ATOMS GAME
+2275	AMIGA BOY (GB SIM)

ASSASSIN'S PD GAMES VOL 1 TO 30
 Still available, the most comprehensive list of PD games ever
 AMIGOLDS, BALLY 2, JUMPER, PACMAN, AIR ACE 2, SLIDER, NEBULA, DR MARIO, DOG, NOVA, BOUNCE + BLAST, CHROME, LEMMINGOLDS, TWINTRIS, BAD, CONNECT 4, CRACKER, WELTRIN, SNAKE PIT, COIN DROP, ZEUS, HOLLYWOOD TRIVIA, DRAGON TILES -> MANY MORE
ALL 30 GAMES DISKS ARE ONLY £29.99 INCLUDING ALL POSTAL CHARGES, INDIVIDUAL DISKS AVAILABLE AS WELL £1.25 EACH
 TELEPHONE FOR MORE DETAILS.
WELL OVER 130 GAMES IN ALL!

17 BIT SOFTWARE, THE BEST PLACE TO LOOK FOR SAVINGS! CHECK OUT THE STASH BELOW!

NEWSFLASH 27 AVAILABLE NOW!
 Packed with utilities, news, reviews etc. a programmer's dream.
 All 3 disks for £6.95.
 2 disk issue £4.95

CDPD ISSUE #2
 The sequel to the first CDPD containing CDPD 2.0 & a compilation of all the best disks from the community.
 Yours for £2.99 + P&P

PHOTON PAINT 2
 With a R.R.P. of £69.99 this HAM art package is a real snip for any art enthusiasts.
 Just £12.95 + 75p P&P
 Incredible value!

SPACE WARS
 At last, Over 150MB of superb ray-traced animation on high grade VHS video. Tobias's movie masterpiece can be yours for **£11.95 + P&P**

CDPD DEMO DISK
 Contains thousands of demos, modules, clipart, utilities etc. This is a bargain not to be missed.
Only £19.99.
 Please include 75p for postage and packing.

14 DISK CLIPART
 EVERY PICTURE KNOWN TO MAN ON 14 ACTION PACKED DISKS
 JUST LOAD INTO YOUR FAVORITE DTP. THE VERY BEST COMP. OF CLIPART ONLY £14.50

10 DISK INSTRUMENT PACK
 The best instruments pack there is, nearly a 1000 Med and Protracker compatible instruments, cut your own licks with this amazing offer
Only £10.50

GRAPEVINE 13!
 Catch up with the latest gossip, news and who's who in the Amiga world. Packed beyond belief with more articles that you could imagine!
£3.75 (3 disk issue)

SWIV
 The Ultimate Shoot Em Up, "Yet To Be Bettered"
 RRP £25.99
ONLY £7.99 + 75p P&P
 NOT + COMPATIBLE SORRY!!

HOBBITS + SPACESHIPS
 The new music CD from Bjorn A Lynne and Fieshbrain. Over 72 minutes of great original music. Recorded on the very latest synth equipment. No AM/FM enthusiast should be without this outstanding music CD yours for only £12.99 don't miss it!

FOOTBALL CRAZY !!
 Kick Off 2, Final Whistle And Player Manager !!
THE BEST EVER FOOTBALL COMPILATION ONLY £12.99

MUSIC DISKS
 +2146 Trip to Trumpton Mix
 +2095ABC Rhythm Is A Dancer
 +2089 Ses St Remix
 +2084 Gospel Karaoke
 +2082 Love Sex Intelligence
 +2049AB Erasure Remix
 2034 Techno Tower
 2002AB Rolling (Superb)
 +1956 Short Modules
 1939 Alister Brimble Music
 +1929 Sonic Boom 2
 +1899AB Drums + Reverb
 +1894 Anarchy Big Time
 Please remember ABC is 3 disks £3.75

AMIGA ACCESSORIES
 180 CAP DISK BOX £7.99
 MOUSE MATS £2.99
 DUST COVERS £2.99
 BLANK DISKS (100) £8.99
 ZIP STICK AUTO £11.99
 EXT. DRIVE £34.99

BARGAIN BACK CATALOGUE COMMERCIAL SOFTWARE!
 WOLFCHILD £12.95
 MAGNETIC SKOLLS £11.99
 BRIDES OF DRACULAR £9.99
 FUZZBALL £9.99
 VENGEANCE/EXCALIBUR £9.99
 BBC EMULATOR £7.99
 SUPER HEROES £12.95
 10 GREAT GAMES £12.95
 FLAMES OF FREEDOM £12.95
 FLIGHT OF INTRUDER £14.95

GAMES DISKS

+2228	WOTON
+2225	CRICKET
+2221	SKY FLIER
+2218	OBLIDOX
+2209AB	OLEMPIAD
+2207	ESCAPE
+2200	TURBO THRUST
+2197	ACT OF WAR
+2192	CHAINSAW MASS
+2191	PINBALL PREVIEW
+2185	SILVER BLADE
+2184	MATRIX
+2176	CROSSMAZE
+2174	KLAKTRIS
+2173	ASSASSIN PREVIEW
+2171	GAMES COMP 90
+2163	GAMES GALORE 12
+2158BA	FRANTIC
+2156	TOP SECRET
+2147	VERB QUIZ
+2141	OTHELLO
+2139	ROULETTE
+2136	POTATOE HEAD
+2130	AIRPORT
+2111	RESCUE
+2110	TANK ATTACK
+2109	DONKEY KONG
+2107	CASTLE NOMIS
+2105	GAMES GALORE 11
+2100	TRAILBLAZER
+2097	DR MARIO
+2090	SOCCER CARDS
+2085	CARD GAMES
+2079	DOMINOES
+2078	NESTER
+2074	MI WOBBLBY
+2060	ESCAPE V2.0
+2051	BALDY

UPDATE 28
 Full of goodies including: Games, Articles, Short Stories, Workbench Hacks, Useful Programs Etc.
 Not to mention the very latest PD lists.
Only £1.75

UTILITIES: +1405 AMIGA FON PC TASK: +1804 SLIDESHOW MAKER +1910 A B WINDOWS BENCH + 1974 B-BASE 2 +2129 TEXT ENGINE 3 4 215 DISK COPIER +1926 MED 2.1 +1054 AMIBASE

PLEASE NOTE ABCD AFTER A DISK NUMBER IS 4 DISKS AND IS £5.00, PLEASE STATE WHEN ORDERING WHEN A PD TITLE IS A MULTIPLE DISK ONE, IF YOU JUST QUOTE THE NUMBER YOU MAY ONLY RECEIVE THE FIRST DISK !!!

AM/FM 9
 CYNOSTIC D0020

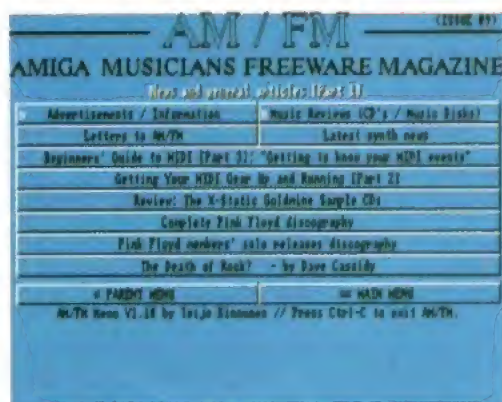
MAG

Maybe *AM/FM* does look a bit too simple, but Teijo Kinnunen's front-end is very easy to use and bug free.

Bjorn Lynne, apart from being one of the most noteworthy musicians in the Amiga scene, is continuing to spread the word through the *Amiga Musicians Freeware Magazine*. OK, it's a magazine on one disk, which means there's not that much to keep you spell-bound. But what is there is very good, and there's also a companion samples disk with each issue – the sample disk is stuffed with drum sounds from a Korg M1, which should ensure many a good beat.

The best part about *AM/FM* is that it's interesting for beginners as well as old hands. It's a shame they scrapped the *MED* tutorial, but there's a lot of other useful stuff there, like a continuing series on MIDI and a few pieces on musical trends (which is what your commercial musicians are really interested in). David Cassidy's 'Rock Is Dead' article is most stimulating, exploring the reasons why 'guitar music' is becoming less popular.

As for the music, it's mostly not Bjorn (just as well, 'cause I find his stuff a bit dry). Kim Jensen, Andre Meyer, Kon Wilms, and Aarno Ylisela have all contributed an invigorating mix of musical styles, which together with the MIDI track for Vangelis' *Chariots of*

PD Update

Emerging from that huge pile of Public Domain disks on the other side of the office is the man who they call **Pat McDonald**. And clutched in his hands he has the latest pick of the free software...

Fire makes for a useful bunch of raw data. Some of the music is playable straight through your Amiga, other stuff needs a MIDI sequencer plus a synth or two to be heard. There's even a 'Recognise this piece of music?' competition. Very good, if a bit small.

BLUE ROSE FONTS EDDIE BARRY

UTILITY

Very useful disk this. First off it has a slideshow of the fonts that are included on the disk – good examples of how to put the fonts to creative use. To be honest, the fonts are more useful for slideshows and demos than for desktop publishing, but this is PD Update, not DTP corner.

The fonts are mostly in colour, for use in *Deluxe Paint III* or later, and are very eye-catching. You get 42 different styles, mostly very large, so if you're looking for stylish fonts to label your creative works, look no further and get this disk. Oh yes, as well as being available from a few PD libraries, it's also available straight from Eddie Barry for the princely sum of £1.50. A shame they're not scalable, but at this price, what do you want, blood?

TACK CRAZY JOE'S 2314

UTILITY

Eyes everywhere – a short *TACK* demo that only runs on 1.5Mb machines. Efficiency is not *TACK*'s strong point.

The Animation Construction Set – should be *TACS*, really. Anyway, whatever you call it, this is just a set of utilities to help you create your own self-booting animation disks with a bit of music on. Before you rush off and try to create a movie, I have to say that the resulting disks are not as good as full-blown demos with their own custom programming. But if you don't know a coder and want to release small animations, this disk could help.

It has to be said that the disk leaves a little to be desired – the way that you create your own disks is to copy the supplied one, delete the animation on it, and put your own there. A similar procedure is used to change the sound module to accompany your animation. Rough and ready really, but it's simple and it works, plus you can do a bit more tweaking if you know your way around the Shell. Not exactly perfect but it's a start. Well done to Gerry Broad and Alistair Hare (Broad and Hare Animations) for a beginner-friendly disk.

METAL LIFE DEJA VU Y109

GAME

Robert Glavas has been working hard on this *Operation Wolf*-style game. The plot is pretty basic – the evil Excel company has been making military robots for illegal export. You've got a nice, big, fun and fast car to stop them. It's very difficult, pure mayhem, not excellent graphics (it was written in *AMOS*) but still a worthwhile release. Not an easy game to complete and very good presentation (heavy metal music is not easy to do on the Amiga, plus the high-score table is wicked).

Continued on Page 168

STOCK CONTROL V1.0 DEJA VU L/111

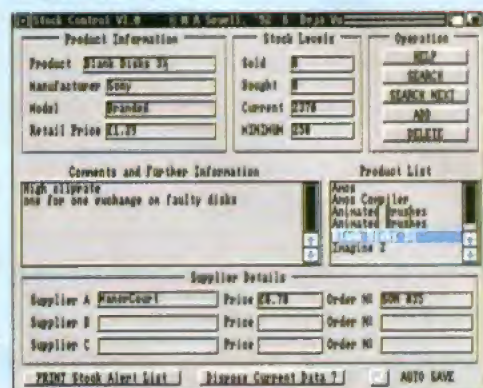
UTILITY

Wouldn't it be nice to be automatically warned when you had to order stock? This does that and more.

This is a release from MA Sewell and it's programmed with *CanDo V1.6*. It's not the greatest stock-control program ever written, but it's easy to use, gentle on the novice, works with a printer and installs to a hard drive. If you've got a small stockpile that you want to keep control of, get this disk. Works best with *Workbench 2*, but 1.3 can be used too if you boot it before you run *Stock Control*.

THE MANAGER DEJA VU L/112

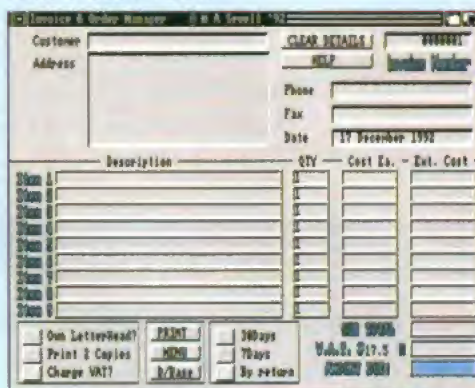
UTILITY

Nine items on an invoice sheet, automatic VAT calculation and fastish printing – what more do you want?

Yet another MA Sewell release, for keeping track of invoices and orders. Very similar in style to the *Stock Control* program, just as easy to use and highly recommended to the lower end of the business community who are willing to give cheap software a try. With both applications you get the programmer's address and telephone number (in the UK) for fast, effective support.

125 KINGSWOOD, THORPE MARRIOTT, NORWICH, NORFOLK NR8 6UW

(0623) 261060

BattleAxe

WE PROMISE YOU GUARANTEED 1st CLASS SERVICE
WE GUARANTEE QUALITY ERROR AND VIRUS FREE DISKS
WE OPEN TILL 9PM TO PROCESS YOUR ORDERS
FRIENDLY TELEPHONE ADVICE WHERE POSSIBLE
ALL ORDERS RECEIVED BEFORE 3PM ARE DISPATCHED SAME DAY BY FIRST CLASS POST

PRINTER PACK

Print just about anything with this pack. Graphics, Letters, Envelopes, Disk Labels, Video Labels, Cassette Labels, Banners, Forms and more also loads of drivers

MUSIC PACK

MED V3.2. THE GREATEST MUSIC MAKER + 4 DISKS FULL OF INSTRUMENTS, BEATS etc... TO GET YOUR REMIXES GOING!! **£6.50**

BITS & PIECES

SPECIAL 1
 100 Cap disk bank inc 10 Branded blank disks, A mouse mat and a disk drive, Head cleaning kit
£15.99

WIN

● **Hard Drive for your Amiga 600/1200** ●
 ● **Memory for your A500/600/1200** ●
 Details with every order & Cat Disk. And on request.

GAMES

- + 904 DRIP (FAMOUS)
- + 908 STARTRECK (2 DISKS)
- + 909 TAXX (ADDICTIVE)
- + 910 CHESS
- + 915 MISSILE COMMAND
- + 916 AMOEBA INVADERS
- + 917 ROLLERPEDE INVADERS
- + 918 AMIGA DRAGON TILES V2.5 Great tiles game
- + 919 ZEUS
- + 920 HOLLYWOOD TRIVIA
- + 922 THE SIMPSONS
- + 925 WIZZY'S QUEST
- + 926 THINK TWICE Master Mind
- + 927 HYPER-BALL Arkonoid clone
- + 929 SEALANCE Submarine Sim, Good
- + 930 SHAPES Good for Kidz
- + 931 WACKO Jr. In Wonderland
- + 934 SCRABBLE
- + 935 WORMHOLE
- + 936 ANAGRAMS
- + 939 SKY FLYER
- + 940 GALACTIC FOOD FIGHT
- + 941 ATIC ATAC
- + 942 D-TRIS (TETRIS)
- + 943 ARCADE CLASSICS inc space invaders
- + 944 NU THE SHOOT EM UP Great stuff
- + 945 CARD GAME Slots
- + 947 E-TYPE The best Asteroids clone, NEW
- + 948 TETREN Best Tetris Clone out
- + 950 15 GAMES by Assassins
- + 951 TOTAL WAR Like RISK (Strategy)
- + 952 YUM YUM
- + 953 BATTLEMENTS Remember HUNCHBACK?
- + 955 INTERNATIONAL CRICKET
- + 956 PIPELINE Like Pipemania Good
- + 957 MATHS ADVENTURE Excellent Maths Quiz
- + 1050 SURVIVOR Dungeon Master Type Game
- + 1051 ESCAPE Escape from the Dodgy Floor
- + 1052 BEAST Corner the Beast
- + 1055 QUADRIX Brilliant Puzzle Type, 10/10
- + 1056 CROSSWORD CREATOR
- + 1057 QUESTIONTORT Create Multi-Choice Quiz's
- + 1092 ESCAPE V3 + Snowgame
- + 1100 GX200 New game
- + 1106 MENTAL IMAGE GAMES 1 and 2 type great
- + 1107 MENTAL IMAGE GAMES 2 Sim above
- + 1150 HELLZONE Close to R-Type
- + 1151 SERENE III Another great shoot'em up
- + 1152 NUMPTY & THE ALIEN INVADERS Music Master
- + 1153 FLAG CATCHER Watch those bombs!
- + 1154 BATTLE OF BRITAIN & WAR Like Risk
- + 1155 ANTEP New
- + 1156 TOP SECRET New
- + 1157 MASHEE NIBLUCK GOLF Golf
- + 1170 ASSASSINS GAMES V30 Another great collection
- + 1171 WIZARD WORLD Great fun and graphics
- + 1172 LEEDINGS Similar to Lemmings
- + 1174 DONKEY KONG Great conversion
- + 1175 FULL HOUSE Play year cards right!
- + 1176 SPACE TRAX Space game
- + 1177 TURBO THRUST Good new Thrust game
- + 1186 RAID Very similar to 5WIV
- + 1187 X.F.I. & H-BALL Like Tron
- + 1198 DOWNHILL CHALLENGE Ski-ing
- + 1199 MEGABALL Arkonoid Clone
- + 1190 PUGGLES Remember Cuddly Cubert
- + 1193 OTHELLO New
- + 1205 SANITY Brilliant new game, slideshow & fab music

UTILITIES

- + 678 SID V2.0 THE LATEST CLI IS A BLAST WITH THIS ONE
- + 797 TYPING TUTOR MEASURES TYPING SPEED AND ADJUSTS LEVEL OF DIFFICULTY
- + 799 CLERK FANTASTIC ACCOUNTS PROGRAM FOR BUSINESS OR HOME
- + 839 DESKTOP PUBLISHER MAKE LEAFLETS etc WITH GRAPHICS + TEXT GOOD
- + 857 SUPERKILLERS KILLS SADAM PLUS 171 MORE VIRUS LATEST
- + 840 TEXT PLUS V3.0C WORD-PRO MENU DRIVEN AREXX SUPPORT THE BEST
- + 808 P.C EMULATOR RUN P.C SOFTWARE COME WITH C.G.A. GFX NEEDS MS-DOS
- + 710 AMBASE POWERFUL EASY TO USE DATABASE WITH 4 MATHEMATICAL FUNCTIONS
- + 858 JR-COMM 1.02 THE LATEST VERSION OF THIS COMMS PROGRAM GOOD
- + 704 NORTH C UNPACK ONTO 2 DISKS COMPLETE 'C' ENVIRONMENT
- + 686 T.V. GRAPHICS 2 DISK BACKGROUND & FONTS FOR VIDEO ENTHUSIASTS ETC
- + 684 VIDEO APPLICATIONS 2 DISK VIDEO UTILITIES TO ACCOMPANY TV GRAPHIS
- + 731 SMOVIE AMAZING TITLE AND TEXT SCROLLER FOR VIDEO ETC
- + 688 DISK SALV MUCH MUCH BETTER THAN DISKDOCTOR ON W.B
- + 681 BATTLEAXE ICON STUDIO THE TOP ICON MAKERS AND EDITOR WITH SOME ICONS
- + 603 D.K.B. TRACE EXCELLENT RAY TRACE PROGRAM
- + 650 QUICKBASE LABELPRINT, VIDEO-LIBRARY, MENU 1 DISK GOOD VALUE
- + 703 GRAPHIC UTILITIES TOTALLY PACKED WITH GRAPHIC STUFF
- + 781/2 DYNAMITE FONTS 1 & 2 2 DISKS FULL OF FONTS TO USE IN DPAINT ETC
- + 761 MEGA UTILS 50+ YES OVER 50 USEFUL UTILITIES
- + 725 ANTI-FLICKER STOPS SCREEN FLICKER IN INTERLACE MODE
- + 885 AUDIO MAGIC V1 FULL OF USEFUL MUSIC SEQUENCERS & SOUND RIPPER
- + 886 AUDIO MAGIC V2 IF YOU HAVE THE ABOVE, YOU'RE BOUND TO WANT THIS
- + 888 DEVPAK SOURCE CODES LOTS OF PROGRAMS FOR YOU TO EXPERIMENT WITH
- + 890 GELIGNITE FONTS MORE GREAT LOOKING FONTS TO USE IN YOUR PAINT PACKAGE ETC
- + 892 MESSY SID II AN UPDATE TO THIS GREAT FILE CONVERTER, AMIGA < PC
- + 844 LITTLE BLEND 2.0 A GREAT WB REPLACEMENT, WITH LOTS OF USEFUL UTILITIES
- + 846 MAGNETIC PAGES MAKE YOUR OWN MAGAZINE ON DISK, OR TUTORIAL etc
- + 1001 MED V3.2 THE VERY LATEST AND BEST MUSIC PROGRAM
- + 1002 ESSENTIAL UTILS III A GREAT COLLECTION OF UTILITIES
- + 1003 ASSASSINS MEGABOOT MASSIVE COLLECTION OF BOOT MAKERS
- + 1004 MR BACKUP V5.02A BACKS UP YOUR HARD DISK IN MINUTES
- + 1006 AMIGA PLUS UTILITIES SPECIALLY FOR THE A500 PLUS
- + 1026 NCCMM 1.921 BEST COMMS PROG + HOST OF ARCHIVING FILES etc
- + 1027 D-COPY V2.0 GREAT D-MOB COPIER, FORMAT, NIBBLE COPY, DOS COPY + MORE
- + 1029 HYPER CAT V1.2 STORE 9999 DISKS/PROGS BY NAME OR DISK NO
- + 1038 PIC BASE SPECIAL DATABASE FOR STORING IFF PICS, VIEW THEM etc KEEP TRACK OF YOUR ART
- + 1042 ASTRO 22 Professional Astrology Great
- + 1053 HARDWARE PROJECTS A GET THAT SOLDERING IRON OUT
- + 1054 HARDWARE PROJECTS B MORE AMIGA PROJECTS
- + 1058 AMIGAZER ANOTHER GREAT ASTROLOGY PROGRAM
- + 1059 PICTURE CONVERTERS PACK CONVERT FROM C64, PC, ST, MAC AND MORE
- + 1060 MEGA MONITOR DOES THE SAME JOB AS ACTION REPLY NEARLY
- + 1122 REORG GREAT DISK OPTIMISER
- + 1124 LE NAG NEW LATEST EDITION EVENT MANAGER/CALENDAR
- + 1123 SCREEN BJANKERS SAVE YOUR MONITOR
- + 1130 FREPCOPY 1.8 LATEST UPDATE REMOVES PROTECTION FROM GAMES
- + 1162 AMIGA PUNT A HORSE RACING PREDICTION PROGRAM
- + 1163 AGRAPH PRODUCES GRAPHS, PIE CHARTS, BAR GRAPHS & MORE
- + 1164 LITTLE OFFICE A WORD PROCESSOR, DATABASE & SPREADSHEET IN ONE
- + 1165 DIRECT ACTION MERGE ANIMATION & SOUND, REQUIRES IBM+
- + 1166 SLIDESHOW GENERATOR CREATE YOUR OWN STUNNING SLIDESHOWS WITH MUSIC!
- + 1167 STRUCTURED CLIP-ART SOME GREAT CLIP-ART FOR PPAGE-ETC
- + 1178 TWIN EXPRESS (2 DISKS) THE BEST PC-AMIGA, AMIGA-PC FILE TRANSFER PROGRAM
- + 1179 AMOS UPDATOR V1.34 UPDATE YOUR AMOS
- + 1180 AMOS COMPILER UPDATOR V1.34 UPDATE YOUR AMOS COMPILER
- + 1191 V.C.R. FILER KEEP TRACK OF YOUR VIDEOS!!
- + 1192 BLUE ROSE FONTS SOME GREAT LOOKING FONTS FOR DPAINT

Books you MUST not go without!!!

- Amiga C for Beginners£18.45
- Amiga for Beginners£15.45
- Amiga Hardware Ref Manual£25.95
- Amiga Machine Language£18.45
- Amiga Rom Kernel Ref. Auto Docs£34.95
- Amiga Rom Kernel Ref. Libs£34.95
- Amiga Rom Kernel Ref. Devices£24.95
- Amiga Dos Inside & Out Revised£26.99
- Making Music On The Amiga£38.45
- Mastering Amiga Printers£19.95
- Amiga Desk Top Video 2nd Edition£20.95

AM/FM

Amiga Musicians FreeWare Mag
 The worlds best Amiga music disk magazine, AM/FM is just great. Full of tips, tutorials on well known software etc. Projects, some absolutely great music with each issue Amiga only and midi. If you are keen with music and your Amiga then you just don't want to miss this. Now on issue 9 and back issues available.
£2.50 per issue

LATEST

- +1121/2/3/4/5 5 DISK C MANUAL NEW
- +1126 CATACOMBE (GAME) GRAPHIC ADVENTURE
- +1127 COLLOSAL (GAME) CAVE ADVENTURE
- +1128 ADVENTURE GAME CONSTRUCTION KIT
- +1129 CV RESUME MAKER GET THAT JOB
- +893 AMBASE PRO LATEST AND GOOD
- +894 UEDIT TEXT EDIT
- +895 AMICASH
- +899 PSUT DISK CATALOGUER
- +900 E-TYPE 2 COULD IT BE POSSIBLE
- +1102 TEXT ENGINE 3.4 NEW
- +1108 THE MAIN EVENT (EVENT/HANDLER GOOD 1 PAID)
- +1078 ELECTRO CAD OBVIOUS
- +1080 DATA EASY
- +1096 TURBOQUILL 1.1 WORDPRO
- +1070 TEXT ALDAD DOC VIEWER WITH SPEECH
- +1099 ZERO G SAMPLES PURE SOUNDS
- +1097 LITTLEBENCH 1.3 A LITTLE WORKBENCH
- +1091 ARP V1.3
- +1090 MEGA VIRUS KILLERS
- +1089 OPT UTILS 2
- +1087 IFF CONVERT
- +1086 SAS UTILS 1
- +1084 CULPRITS UTILS
- +1082 WORKBENCH HACKS
- +1081 SUPER C
- +1083 32 HELPPUL UTILS
- +1093 EYE OF THE BEHOLDER HINTS MAPS & SOLUTIONS
- +1103 BRAINSTORM MUSIC DISK GOOD SOUNDS
- +1131 E-TYPE 2 GREAT GAME
- +1136 CANON & HP PRINTER DRIVERS
- +1137 STAR & CITIZEN PRINTER DRIVERS
- +1138 PRINTER & PLOTTER DRIVERS HUGE SELECTION
- +1139 ALL ROUNDER GREAT NEW GAME

Catalogue Disk with FREE GFX Ripper **£1.50**

FOR ANY AMIGA

Compiled by us these disks are the best and latest editions. Our aim is to put a collection of progs of the same theme together. The disks self boot. No need to load workbench. They have easy to find, easily understood, easy to print instructions.

- FX1 The Print WorkshopUtilities
- FX2 The Hard Drive Workshop.....Utilities
- FX3 The Graphic Workshop.....Utilities
- FX4 The Video Titlers Workshop.....Utilities
- FX5 The Packers Workshop.....Utilities
- FX6 Disk Repair Workshop.....Utilities
- FX7 Hachers Workshop.....Utilities

£1.50 each

BUSINESS PACK

WORDPROCESSOR, SPELL CHECKERS, DATABASE, SPREADSHEETS, ACCOUNTS & MORE Regularly updated with latest
£6.50

EDUCATION PACK

Contains following educational programs: SpellCheck, German, Spanish & French Tutor, Study Aid, Counting, Division, Mathematical, Reflex Test, The Weather, CalcKey, Gravity Well, AirFoil, Unit Converter, World Databank, Plot, Quiz, Sherlock, Evo, Capitals, Maths Adventure, Elements, The Gallows & CryptoKing.
£6.50

GAMES PACK

Packed with great games from arcade to board games including: Amiga Taxx, Amoeba Invaders, Missile Command, Rollerpede, Copper, PacMan, Galaga, SYS, Towers, BackGammon, Amiponds, Space Rescue, YachtC, Drip, Chess, Nuka, AirAce II, SubAttack and 15
£6.50

DISKS 1-10 **£1.50**
 10+ **£1.25**
 TBAG, FISH **£1.50**

POSTAGE ALL ORDERS £1 SAME DAY DISPATCH UK **£1.50 EUROPE £3 REST /WORLD**

DESKTOP VIDEO PACKAGE

ALL ORDERS RECEIVED BEFORE 3PM ARE DISPATCHED SAME DAY ON GUARANTEED ERROR FREE DISKS. ALL ABOVE WORK ON 500, 500 PLUS & 600. ORDER TILL 9 EVERY NIGHT 7 DAYS A WEEK
 This pack has been made due to the great demand for this type of material. It consists of: SMOVIE the text scroller, 2 disks full of backgrounds & fonts, & 2 disks full of Video Application utility software.
£6.50

UGA AMIGA INTRO PACK

GREAT COLLECTION OF PROGS TO HELP YOU GET THE MOST OUT OF YOUR AMIGA - MAKES LIFE VERY EASY - TEXT EDS, COPIERS, DIR UTILS, CRUNCHERS - WELL REVIEWED IN AMIGA COMPUTING JUNE ISSUE
£5.00

AMIGA 1200



Amiga 1200, 68020 processor, 14.19Mhz, 32-bit, 2Mb chip RAM standard, AmigaDos v3.0, optional hard drive (see below), AA chip set for enhanced graphic capabilities, 16.8 million colour palette, 2-256,000 colours on-screen, PCMCIA smart card slot for memory exp, 96 key keyboard with numeric keypad and 1 year on-site warranty. Also with free package from BattleAxe containing a word processor, database, spreadsheet and 3 games...

Prices for AMIGA 1200 Inc Hard Drive

Amiga 1200
with 85Mb
Hard Drive

£ Call For
Low Low
Prices

Amiga 1200
with 120Mb
Hard Drive

£ Call For
Low Low
Prices

Hard Drive Models Come With Our Own 12-Months Warranty

HARD DRIVES 1200/A600

We can supply, or install a fully compatible 2.5" IDE hard drive at a very compatible price. Complete installation and full easy-fitting documentation included. Fully guaranteed for 12 months. Various sizes including:



85Mb 120Mb
£CALL NOW! £CALL NOW!

Prices varying constantly, call for lowest available price.

MODEMS/COMMS

The Supra-Fax Modem

V.32 bis (14400 baud!!!)
Allows you to send and receive fax messages. This new modem from Supra has full 1400 baud capability. Spec includes V.32bis, V.32, V.22bis, V.22, V.21, MNP2-5, V.42, V.42bis, Class 1 & 2 commands, 9600/14400 Group 3 Fax. Includes free comms software and modem cable.

£249.99

The Supra-Fax 2400

(upto 9600 BPS)
With the ability to send faxes! Even faster than the standard 2400 from Supra with auto-dial & auto-receive, 9600 bps Hayes comp. V22, V42 Bis, MNP 2-5 & auto adjust to maximise transmission speeds. Includes free modem cable and comms s/w.

£129.99

Supra 2400

Get on line using this great value fast modem with auto-dial and receive. 2400 baud Hayes comp. V22 BIS. Inc modem cables and comms s/w!!

£75.99

E&OE
Prices subject to
change without notice

PERIPHERALS

Triax Turbo Touch 360

Fantastic New Console Type Control

A radically new style of hand-held controller from Hornby. Feather-touch direction pads mean no buttons or switched. We believe this will improve gameplay and provide superior control!!

£? Please Phone for Turbo Touch Prices

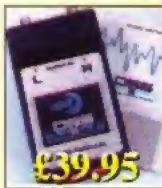

G.V.P. Digital Sound Studio

High quality 8-bit stereo sampler. Sample upto 51,000 samples/second in stereo. Special effects inc echo, mix, filter, re-sample & much more. Works with any Amiga inc 1200, 4 track sequencing software with midi support, create SoundTracker compatible and stand alone song files with the great DSS software.

COMPATIBILITY PROBLEMS? (A500 Plus owners)

Switch-It is the CURE! £22.95

If you have an A500 Plus and you are fed up with incompatible software, or you have upgraded to one of these machines and all your old software fails to work, then here is your answer. Includes audible switcher, keyboard controlled. (See box right for ROM prices). Needs required Kickstart chip.

CREDIT CARD HOTLINE

9am (0603) 261060 9pm



VIDEO

G.V.P. CINEMORPH

£84.99

Amazing special morphing effects at a price you can afford!
G.V.P.s Cinemorph allows you to create in your home what usually needs a professional video studio and a bank loan. Morphing is the process of merging from one image to another, whether it be a human or a car etc. CineMorph gives you the opportunity to do this in a very understandable and user friendly way. Creating animations and stunning effects to give your video productions that bit of class and excitement!!!!

! NEW ! NEW ! NEW ! NEW !

NEW!! G.V.P. G-LOCK GENLOCK

!!! Supports AA Chip Set (Amiga 1200/4000) !!!



£294.99

Features include:

- 2x composite video, 1xS-VHS inputs.
- RGB composite video & S-VHS outputs available simultaneously.
- Sound mixer, 2 mono inputs & 1 output.
- Full software control via control panel, hotkeys and/or ARExx.

GVP's G-LOCK Genlock is a true price/performance breakthrough. Works with all Amiga computers and even supports the new chrome key modes of the ECS/AA chip set (Amiga 1200 etc). The only choice for the mid-range Amiga video enthusiast.

NEW LOW PRICED

SOFTWARE

GOLD DISK OFFICE II

5 fully integrated programs that make an easy to use, highly productive office W.B.2 compatible. (Write) Word Processing. (File) Database Management. (Graph) Business Graphics. (Calc) Spreadsheet Calculations. (Page) Desk Top Publishing.

£129.95 £54.50

IMAGE FX

£179

High powered image processing system

Lattice (SAS C) V6

£225.50

The greatest C Compiler/Environment

Improve your printers
quality (24-pin) with

TRUEPRINT 24

Now! £52.50

ACCESSORIES

100 Capacity Disk Box	£7.99
Mouse Mats	£3.99
Modem & Null Modem Cables	£9.99
Amiga to Scart Cables	£9.99
Disk Drive H/Clean Kit	£3.99
Printer Cables	£6.99
Rom Sharer 500	
Keyboard Operated Audible	£22.95
Kickstart 1.3 Rom Chip	£21.99
Kickstart 2.04 Rom Chip	£34.99

BRANDED DISKS

LIFETIME GUARANTEE ERROR FREE
BOXED IN 10's WITH LABELS

10	£6.99	50	£28.99
100	£54.99	500	£229.00

When ordering by post, please make cheques payable to BattleAxe, and include Name, Address, Postcode and if possible a daytime telephone number along with your order requirements. Thankyou.

BattleAxe

125 KINGSWOOD, THORPE MARRIOTT, NORWICH, NORFOLK NR8 6UW



Machine mayhem with a big gun. Don't expect to last more than 10 seconds until you've practised a bit.

HARD DISK MENU

UTILITY

DEJA VU L/118

This is MA Sewell's (see bottom left on previous page) most useful program yet. *HDM* sets up a simple menu on your hard drive, to run programs simply by pointing and clicking at the name, rather than wading through heaps of directories and drawers.

This sort of utility is fairly common, but this one has good documentation, a separate installer for NTSC systems (how often do programmers understand the difference?) and is easy to use. Hard disk users who don't have a menu system yet, do look at this but remember that it uses a bit of memory, so really memory-intensive programs tend not to work unless you have a couple of megabytes of spare memory.

LEXESS

GAME

NBS 13/G6



Hangman anyone? *Lexess* knows about 1,000 different words to test on, and is very easy to play.

Nice little freeware version of *Hangman*. Big deal, I hear you say, there have been computer *Hangman* games for donkey's years. Well, the reason I mention it is that for a start, it's written in *AMOS*, and for another thing, it's very, very easy to use. If you're a programmer looking for good examples of programming that are easy on the end user check this out. Well done Ashley Willis and Christine Perkin.

FINAL FRONTIER 3

MAG

CYNOSTIC PD D00003

Four disks packed to their write-protect tabs with *Star Trek*-related material. Simon Plumble, the editor, has boldly gone on a crusade to broadcast all information relating to the crew of the *Starship Enterprise*. The only slightly spurious inclusion is a music track by Echo of LSD, but as it's rather good I'm not complaining. If you want fake but funny scripts, latest news on Paramount's continuing *Star Trek* releases, listings of fan clubs, plus lots more, get this and enjoy.

MONEY SPINNER

GAME

DEJA VU L/110

This game is unique. It shares certain similarities with many different games, and combines them all in a subtle blend. The closest game I have seen to it is *Rotox* - you control a ship in the middle of the screen, and the playing area spins around you. The idea of the game is simply to get back to Earth - your ship made a pioneering trip into hyper space, and the natives really aren't friendly.

Graphically the game is pretty dire, with flickery, wobbly graphics and some jerky animation. The actual in-game graphics are poor, but the sounds and odd playability make up a little for this deficiency. If you want a weird, weird game, get this - the graphics are not amazing but the gameplay is quite original.

Personally, I reckon that the author, Neil Murphy, could be the next Jeff Minter if he stops using *AMOS* and just uses machine code. Bruce



Zapping, spinning, twisting, turning and grabbing. Five basic game elements that are very hard to put down.

Murphy better keep practising with *Deluxe Paint* too - I mean, he's a better artist than me, but that's not really saying much. Quality, not quantity would have made for an even better game.

PACMAN 92

GAME

STARTRONICS 323

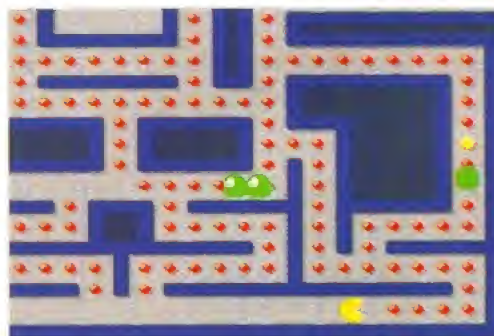

Pacman, the Pizza with a slice missing. Ancient game, still loads of fun, especially with the game changes.

This is a new one for me, but I am assured that it's quite an old release now. *Pendle Europa Super Pacman 92*, to give it its full title is a rejigging of the famous partial pizza that can't stop eating. The playing area is bigger than the screen, and smoothly scrolls to show the local ghost activities. A pity there's only three types of ghost, but the way they appear is novel.

Each of the ghosts has different behaviour patterns which makes it a very different kind of *Pacman*. The mix of ghosts and mazes means you need more skill than before. Also, the power pills don't last long, but you can avoid the ghosts in the tunnels. Nostalgic fun.

AGENE V4.34

UTILITY

AMIGANUTS



AGene is a bit less powerful than before (less records per disk) but you can store more facts about the individuals.

Genealogy is the study of family trees, and is a pastime where a computer can be extremely useful. This is the best current program for the job, and has been updated many, many times (as long-term readers will know).

It's indispensable for recording ordinance information for members of the Church of the Latter Day Saints (Mormons, to use the common term).

The new features include *Soundex* (which is a system for cataloguing similar sounding names, like Smith, Smyth and Smythe, as used by various national revenue and census organisations) and *Gedcom* (so that you can swap data with similar programs on the Mac and PC). Also, the *ADoc* on-line help system by M Denis Gronelle has been implemented - with M Denis Gronelle's permission - to help new users find their way around.

TOP 10 GAMES AND UTILITIES

Every month we print the top 10 games and utilities from a PD library. This month it's the turn of...

STARTRONICS PD

- 1 Pacman 92
- 2 Leap!
- 3 Cybernetix
- 4 Assassins 040
- 5 Dragon Tiles
- 6 Bounce 'n Blast
- 7 Raid 3
- 8 Mental Image Games 2
- 9 Soccer Cards
- 10 CLR CLE011 Let's Learn

WHERE TO GET THE DISKS IN THIS ISSUE

- AMIGANUTS:** 12 Hinkler Road, Thornhill, Southampton
- CRAZY JOE'S:** 145 Effingham Street, Rotherham South Yorkshire, S65 1 BL. 0709 829286
- CYNOSTIC PD:** 85 Wyken Croft, Coventry, CV2 3AD. 0203 613817
- DEJA VU SOFTWARE:** 7 Hollinbrook, Beech, Wigan, WN6 7SG. 0942 495261
- EDDIE BARRY:** 32 Glenmore Walk, Hilden, Lisburn, N Ireland, BT27 4RY
- NBS:** 1 Chain Lane, Newport, Isle of Wight, PO30 5QA. 0983 821983
- STARTRONICS PD:** 4 Arnold Drive, Droylsden, Manchester, M35 6RE. 061-370 9115



United Public Do

The innovators

Look out for the CLR logo!

THE BEST SELECTION OF PD IN THE UK!

- GAMES**
- PG003 AIR WARRIOR Good night Sim +
 PG006 ANTER & SLOTT CARs role playing game+ Y
 PG008 ASI 1 Tan, Rollerpede, Avetrli Amigoids etc+
 PG009 ASI 2 Invaders, Baby 2 Missile command etc+
 PG010 ASI 3 Megaball & Dip Super 1+
 PG011 ASI 4 Frog, Go Loko, Cracker Jumpy etc+
 PG012 ASI 5 Road, Go Moby, & Retaliator+
 PG013 ASI 6 Pacman Downhillchance Wellbrix etc+
 PG014 ASI 7 Moonbase, Trix, Nightworks Clouderunner+
 PG015 ASI 8 Airace 2, Hball, Snakepit, & Numbertumbler+
 PG016 ASI 9 Features Battle pong & Blizzard+
 PG017 ASI 10 Escape, Pipeline, Pickout & Syst+
 PG018 ASI 11 Dad, Connex, Reverser Towers & Trippin+
 PG019 ASI 12 Llamatron, Car, Powerpong, Fabl+
 PG020 ASI 13 Twintins, Squamble, Block it, Ball etc+
 PG021 ATIC ATAC Really playable 1 + Y
 PG024 BLACKJACK Good card game 1+
 PG026 CASTLE OF DOOM Excellent! Get it + Y
 PG028 COLOSSUS & WORLD Fab adventures 1+ Y
 PG029 CROGWOOD COMPILER As it says 1+ Y
 PG032 DRAGONS CAVE D&D style game Mega+ Y
 PG034 ETERNAL ROME Strategy & DOMINOS+ Y
 PG045 HAK Great text adventure-infocom style+ Y
 PG047 HOLLYWOOD TRIVIA Nice Trivia Game! + Y
 PG048 HOLY GRAIL One of the best text adventures+ Y
 PG051 KILLER CARS Great filled vectors game+ Y
 PG053 LARIN A superb text adventure game+ Y
 PG059 CORE OF CONQUEST space trading D&D game Y
 PG062 MENTAL IMAGE 1 Gndrunner invaders & rebound+
 PG068 NO MANS LAND Hi tech war game shoot em up+ Y
 PG071 POM POM GUNNER Like beach-head on the 64+ Y
 PG072 PROPERTY MARKET Become a millionaire!!! + Y
 PG074 RETURN TO EARTH Elite space trading game! + Y
 PG076 SEVEN TILES Speedball type game-MEGA!
 PG079 SEALANCE A submarine strategy game + Y
 PG080 SERENE COMBS quality shoot up! + Y
 PG081 SERENE II Follow up to the above game+ Y
 PG085 STARFLEET Nice game done in SEUCK! + Y
 PG094 TRAIN CONSTRUCTION KIT make own tracks+ Y
 PG101 THE INSIDERS Club Stocks & shares game
 PG105 WIZZY'S QUEST Fab arcade adventure game+ Y
 PG108 ASI 14 China Challenge 2 & Amiga Columns! + Y
 PG110 SUPER SKODA CHALLENGE Nice car race game! + Y
 PG121 ASO06-GAMES PACK 21 games to run on a plus+ Y
 PG124 TOTAL WAR Great new high tech war game+ Y
 PG127 IRMIRANIA Super platform game from Addwate+ Y
 PG131 ATLANTIS A nice looking strategy game + Y
 PG132 ASI 15 Battlearms Lethrix & Mambomovel+
 PG133 ASI 16 Wastelands, Mission X, Pacman +
 PG134 ASI 17 Tomcat, Delenda, Jetman Bugblaster+
 PG135 ASI 18 Henry in Panic Skyfyer Omega race!
 PG136 ASI 19 Growth, FrankFreddy, Biplane, & more+
 PG138 BATTLE OF BRITAIN & WAR strategy war games+ Y
 PG139 DUNGEONS OF MADROJ Excellent! D&D game+ Y
 PG140 MIND GAMES Stacks of fun with this Y
 PG141/3 SWORD OF WARLOCK RPG adventure 2drives
 PG146 ASI 20 Microbes Hollywood trivia Coin drop +
 PG149 A NIGHT AT THE TOWN WITTY text adventure+ Y
 PG153 WAR very good strategy/arcade game+ Y
 PG155 ASI GAMES 21 Zeuz Tetrix Battlements D'raghties+
 PG156 ASI GAMES 22 Lermingdome, Wizzy, Sweet, Uel etc+
 PG157 ASI GAMES 23 GAMER, BIP Inter on Arcadia+
 PG164 GAME TAMER 23 Ipyclic tester & 268 cheats+ Y
 PG166 RAID III Wicked new shootem up!!! + Y
 PG167 SERENE III From the author of RAID!!! + Y
 PG169 ASI GAMES 24 Revenge Dux Croak 3d maze etc+
 PG170 ASI GAMES 25 Mr Brick, Copper, hemeroids, E Type+
 PG171 ASI GAMES 26 Superpacman 92 Smash tv Ashido+
 PG172 ASI GAMES 27 Addictive card games, Really good!
 PG174 AMOS GAMES 28 Shareware cricket game 1 or 2drives
 PG175 SPACETRAX 2 player shoot off other up game+ Y
 PG176 TECHNOBAN GAME Quite a nice puzzle game! + Y
 PG177 HELLZONE Stunning R-type clone-GREAT THIS!
 PG178 MENTAL IMAGE 2 Three Excellent new games +
 PG180 SECTOR 1 A nice game similar to alien breed+ Y
 PG181 STRIKEBALL Baseball type game done in Amos+ Y
 PG182 ETHOS Simple graphical adventure Sinda by Amos+ Y
 PG183 CATAOCOD Super D&D style game VG GFX + Y
 PG184 FATAL MISSION Very good Shootem up game!
 PG186 ASI 28 Doody, DrMario, Invaders2, Madbomber2+
 PG187 ASI 29 Dogo, Rome, Nova, B-Bal, Atax, Quadrix+
 PG188 ASI 30 Bounce & Blast, Total Fire Tank attack!
 PG189 SPACE RESCUE Super scramble like shoot em up!
 PG190 TOP SECRET An excellent quality platform game!
 PG191 ACT OF WAR New space strategy game! + Y
 PG192 MASHIE NIBLOCK Yes a golf game for your Amiga+ Y
 PG193 LAKTRIX Superb strategy type game!
 PG197 ANDYS AMOS GAMES 6 good games on here! + Y
 PG198 AIRPORT Now you control an airport!
 PG199 CASHFRUIT Nice fruit machine game! + Y
 PG200 ALL ROUNDER CRICKET New cricket game+ Y
 PG201 APPLE CATCHER Simple fruit collection!
 PG202/3 IRON CLADS Good strategic war game! 2Y
 PG204 THRALLBOUND Text adventure with graphics+ Y
 PG205 SCORER Football managing game!
 PG206 ASI 31 Aramaz, Crazy pipe, revolution etc!
 PG207 ASI 32 Blob, Sector one & Firefighter!
 PG208 ASI 33 Hyperball & War!
 PG209 ASI 34 Trailblazer, Yelp, Cyber Routhour!
 PG210 ASI 35 Pong, Snakepit, Cybermix etc!
 PG211 ASI 36 Mother lode, Wonderland, Kong etc!
 PG212 ASI 37 Klaktirs, Ghostship, Pacer etc!
 PG213 ASI 38 One on One Baldy, Skyflyer2, Transplant!
 PG214 LEGEND OF LOTHIAN Superb! Ultima type game! + Y
 PG215 ASI 39 Lots of card games on this disk!
 PG216 ASI 40 Disk full of sliding puzzle games!
 PG217 ASI 41 Pacman delusion, Hellzone Leap II etc!

PE0214 SCIENCE Very good four disk set! (4)

BUSINESS

- All ok on A1200 except PB006!!
- PB001 AMICASH bank management program+
 PB002/3 ANALYTICAL/CL Superb spreadsheet! (2)
 PB004 ASI LABEL PRINTER'S 3 of the best+
 PB005 BANKIN control your cheque book!
 PB006 BUSINESS CARD MAKER Nice program+
 PB007 CLERK Complete accounts package+
 PB008 DESKTOP PUBLISHER Simple to use +
 PB009 FLEXYBASE DATABASE Address Keeper+
 PB010 JOURNAL Keep track of finances
 PB011 MISG BUSINESS Geotime, Grocery list, Calc
 PB012 Q&E Simple & field database
 PB013 QED Simple & effective text ed+
 PB014 RIM DATABASE Fully relational!!
 PB015 TEXTPLUS V3.00 THE BEST Wordprocessor +
 PB016 UEDIT ISSUE 3 NEW VERSION Text Editor+
 PB017 VISICALC SPREADSHEET Simple to use+
 PB018 WORDWRIGHT Wordpro with spellchecker!
 PB019 BUSINESS LETTERS contracts, letters + more+
 PB020 TEXT ENGINE 3.4 NEW Version !!
 PB021 AMIBASE RADIO 1 Interfaced to radio hams + Y
 PB022 B2BASE II v5.5 A fast & easy to use database+
 PB023 FORMS REALLY UNLIMITED form creation prog+
 PB024 LAST WILL & TESTAMENTS Just in case! +
 PB025 EDWORD Brand new wordpro - V good +
 PB026 AGRAPH Super Program graphing data +
 PB027 BOLERPLATE Business letters & Wordpro +
 PB028 LITTLE OFFICE Integrated Wpro, Stn.Dbase,Gfx+
 PB029 ADDRESS ANIM Gymnast swings on bars! + Y
 PB030 THE MONEY PROGRAM Home accounting!

UTILITIES

- (Note: "Y" = ok on A1200)
- PU002 A-GENE Good genealogy program + Y
 PU004a/b A64 EMULATOR NEW VERSION 2.0 (2)
 PU005 AMATEUR RADIO 1 Interfaced to radio hams + Y
 PU010 ARP 1.3 AmigaDOS replacement project!
 PU012 ASI GRAFTIX UTILS graphics converters etc+ Y
 PU013 ASI BOOT UTILITIES bootdisk utilities + Y
 PU015 BIORYTHMS, STARCHART 2 Good programs+ Y
 PU021 C-LIGHT RAY TRACER Good program+ Y
 PU022 CHEMESTHETICS molecule displayer + Y
 PU026 CURSER BASIC COMPILER Just what you need! + Y
 PU037 D-COPY The best! PD disk copier & more + Y
 PU039 DBW The forerunner to Skulpt 3D III! + Y
 PU040 DEMOLISHER 168 UTILITIES - MEGA II + Y
 PU047 DOPE INTROMAKER Make your own intros+
 PU048 DYNAMIC FONTS II CuiNPaste screenscreens Y
 PU049 DYNAMIC FONTS More CuiNPaste Fonts Y
 PU055 ELECTROCAD DEMO circuit designer +
 PU056 EXILE FONTS Excellent GnP fonts
 PU058 FONTS AND RAM MANAGER BIG video fonts+
 PU059 FONTS & SURFACES Backdrops & fonts + Y
 PU062 GRAPHICS UTILITIES Various misc. programs+ Y
 PU063 HAMLAB Convert VGA PC to IFFHAM + Y
 PU064 HARDDRIVE UTILS MRBackup & FixDisk & more+ Y
 PU065 ICONMANIA Program icons & more! + Y
 PU066 ICONS Cardm packed with icons! + Y
 PU067 IMPLODER V4.0 Megacrunching Util+ Y
 PU071 JR COMM 1.02 Modern users comms package Y
 PU072 METAL LOW LIT, SLOW EDITORS, & more utilis+ Y
 PU075/8 KING OF THE BIBLE Old/new testaments (4)- Y
 PU078 M-CAD Hires design package, Excellent + Y
 PU080 MESSY-SID Read/Write PC Files, Brilliant! + Y
 PU083 MORSE PROGRAMS for the radio hams + Y
 PU087 NORTH C 1.3 (2) Complete C compiler & libs+ Y
 PU088 NORTH C 1.3 This is the packed 1 disk version! + Y
 PU089 FASCAL COMPILER needs good CUI knowledge+ Y
 PU091 FRENCH 209 UTILS An essential collection+ Y
 PU092 PRINTER DRIVER GENERATOR & new drivers + Y
 PU096 PRINTER DRIVER UTILITIES Various utilis etc+ Y
 PU097 PRINT STUDIO V1.25 Prints pics & text etc + Y
 PU108 ROT A simple 3D drawing package. Very popular + Y
 PU109/10 (2 disk) Structured clipart for Ppage + Y
 PU112/3 SOMETHING FOR NOHIN VIDEO UTILS&Fonts+ Y
 PU115 ST EMULATOR Run Atari ST software 1/2 Drives
 PU117 SUPERKILLERS Virus Killers! You need this! + Y
 PU125/2 TV GOLF DRIVER BIBLE Old/new testaments (2) Y
 PU126 ULTIMATE ICONS Iconmaster, Iconlab + Y
 PU129/30 VIDEO APPLICATIONS Video utilities+ Y
 PU136 ZX SPECTRUM EMULATOR Now with sound + Y
 PU139 GRAPHICS CONVERTERS PC-Amiga Gfx Converter
 PU140 TLIBENCH File copier & utils Dos2 only
 PU141/2 TAROT II Learn about your stars! + Y
 PU143 OPTITRALS 1 Crammed full! Get it! + Y
 PU144 OPTITRALS 2 Get this disk too! + Y
 PU145 OPTICOMMS 2 Nicom 2 & more + Y
 PU149 ELECTRONIC PROTOTYPY Veroboard designer Y
 PU150 FOOTBALL LEAGUE Ed Update league positions Y
 PU151 BROTHERHOOD UTILS 1 Doopy, Scenery, Qed + Y
 PU152/66 CLIPART SET 15 Disks of the BEST clipart + Y
 PU167 MULTI-PILOT Superb data plotting program! + Y
 PU169 GELIGNITE FONTS CuiN Paste fonts+
 PU170 P-SUITE Disk magazine maker+
 PU171 OPTICOMMS 2 Nicom 2 & more + Y
 PU172 WORDPOWER Solve Anagrams/Crosswords+ Y
 PU174 ASTRO 22 professional astrology program + Y
 PU175 GELIGNITE FONTS II Excellent IFF fonts+ Y
 PU176 GELIGNITE FONTS III More of above!! + Y
 PU177/8 BENCHMASTER Windowsbench & Messyaid!
 PU182 STOCK ANALYST Technical analysis program+ Y
 PU183 AMYGEN Excellent genealogy program+ Y
 PU184 PROCAL 1.0 professional calculator!
 PU185/6/7/8/9/10/11/12/13/14/15 Packed with fonts+ Y
 PU189 TRONIK VIRUS KILLERS 21 virus killers & docs+ Y
 PU191 LANDBUILDER fractal land generator+ Y
 PU192 SID 2 Get this I! directory util!!! MEGA! + Y
 PU197 M0BED 2 Dpaint for Sprites & bobs+ Y
 PU198 VIDEO WPES Masks & fades Dpaint 3/4 + Y
 PU201 MALICE FONTS Excellent tiny fonts for Dpaint+
 PU202 CYCLOPS Weird Plasma/fractal creator! + Y
 PU203 SCOPE 194 Util's & Clips for Ppage + Y
 PU205 PC TASK WIKED PC Translator Get it!!! + Y
 PU207 MULTISID Combine SID2 & Multidos(PC-AMIGA)+ Y
 PU208 ASI HANDYTOOLS 3 mega compilation of utilis Y
 PU209 FRED FISH CATALOGUE contains FISH 1 - 680 + Y
 PU210 PCO PASCAL Latest version of Pascal compiler+ Y
 PU211 AMIGA PUNT A horse race predicting program+ Y
 PU212 PERM CHECK PLUS a pools prediction prog Y
 PU213 RACE RATER Another horse racing program! + Y
 PU214 DIR WORK A Sid type file copying program + Y

- PU215 CAPTIONATOR Superb shareware video titling+ Y
 PU217 BROTHERHOOD UTILS 2 utilities for the plus+ Y
 PU218 ORDER Excellent demo of commercial Dbase+ Y
 PU219 WBHACKS- Collection of hacks for + owners+ Y
 PU221-225 8 COLOR ICONS Hundreds of new icons + Y
 PU226/7 C-EYES FONTS For use in Dpaint, WB, etc (2)+ Y
 PU228 PROBABLY RIPPER Create disks easily with this! + Y
 PU229 JPEG 24 bit graphics compression util disk! + Y
 PU230 MORE PRINTER DRIVERS new printer drivers+ Y
 PU231/5 PAGESTREAM FONTS 5 disks super fonts! (5) Y
 PU236/7 SCOPE197/8 Adobe type fonts, 2 disks full! + Y
 PU238/9 M.O.R.C. Mouse operated rune caster, oracle! +
 PU240 FRECOPY V1.4 powerful disk copying program+ Y
 PU241 CALORIE BASE Useful for people on a diet! + Y
 PU242 TEXTPLUS PROFESSIONAL 4 needs hard drive! + Y
 PU243 ASPICE Circuit analysis program+ Y
 PU244 BOM APPETIT This is a recipe database program+ Y
 PU245/256 C MANUS latest version on 12 disks! (12) + Y
 PU257/61 PAGESTREAM FONTS 2nd set of fonts! + Y
 PU262 RICHARD SMEDLEY COMP II Mortgages etc! + Y
 PU263 LYAPUNOV Fabulous & unusual fractals! + Y
 PU264/8 OUTLINE FONTS For Pro pagev3 ONLY! + Y

ANIMATIONS

- PA031 BASKETBALL A basketball player 1 Meg! + Y
 PA039 ERIC-S AMY VS WALKER Cute & sexy! 1.5M + Y
 PA040 ERIC-S BATMAN vs JOKER Very funny!!! + Y
 PA042 ERIC-S COYOTE STRIKES BACK 1mp tool +
 PA043 ERIC-S MORE AEROOTONS Very witty!!! + Y
 PA045 ERIC-S STEALTHY II Mfg-29 vs Stealthy! + Y
 PA046 FRANKLYN THE FLY Day in the life of a fly! + Y
 PA048 GYMNASI ANIM Gymnast swings on bars! + Y
 PA053/4 LIGHT CYCLES (2) Tron animation!
 PA056 MAGician II Good RT animation+ Y
 PA060 NEWTONS CRADE RT animation +
 PA065/68 REAL 3D (4) Superb of the program+ Y
 PA072 THE JUGGLER A classic amiga demo! + Y
 PA074 THE WALKER vs The Helicopter - Mega! + Y
 PA075 THE WALKER vs A2000 A classic! + Y
 PA082 TIM TOY ANIMATION Ray traced tin soldier! + Y
 PA085 JET ANIMATION Fractal flight but better! + Y
 PA086 FRACTAL ANIMATION full screen low flying anim+ Y
 PA090 TOO MUCH 3D Ship hys out of monitor! + Y
 PA091/3 GAS TURBINE, STEAM & PETROL ENGINE (3)- Y
 PA094 AMY JOGS, WALKS & SNEEZES by E Schwartz! + Y
 PA095 HOW TO RUN INTO A WALL by Eric Schwartz! + Y
 PA097 SMALL STATION AT KHERNE New 1mp version+ Y
 PA098 EASTER ISLAND ANIM A nice fractal animation+ Y
 PA099 FRACTAL ANIMATION Fractal flying anim 11M +
 PA100 VOLD CONTEST Check out this new ES anim! + Y
 PA101 DOLPHIN DREAMS Great Dolphin anim! + Y
 PA102 KATTLE OF BRITAIN Amusing short anim! + Y
 PA103/4 BATTLEFISHER 2 Superb bird animations! + Y
 PA105 TOR ANIM Dog jumps out of screen! + Y

AGATRON

- All ok on A1200!
- AGA01 RED LOTUS Spinning down the road. Fantastic! +
 AGA03 STAR TREK - Shuttle fly past - Great! 11m +
 AGA09 STAR WARS - Fighter fly by, impressive! 1m +
 AGA10 STAR TREK - Enterprise in dry dock. Incredible! +
 AGA20 Huey 2 A helicopter leaving a landing pad +
 AGA21 ENTERPRISE DOCKING WITH SPACE STATION+
 AGA22 ENTERPRISE APPROXING stunning anim 11M +
 AGA23 FLEET MANOEUVRE Stunning animation! 1m +
 AGA24 KULI PEN animation & Ping pong. Great! 1m +
 AGA25 THE RUN, a superb car chase 1mp +
 AGA31 PORSCHIE anim rising out of table 1 mg +
 AGA33 PROBE Bird of prey animation & Klingonhit! 1m+
 AGA35 SPACE PROBE, great anim of probe zooming off! +
 AGA36 BIRD OF PREY, loop the loop animation 1m +
 AGA37 TOTAL GOES AWOL - Check this out! 11m +
 AGA38 TOTALLY WICKED 1 Shuttle & Enterprise (2 MEG) +

POWERANIMS

- PP001/2 ANTI LEMMINGS (2) This is Brilliant! 2M +
 PP003 AT THE MOVIES Cute anim of Amy squarred 1.5M+ Y
 PP008/10 BUZZED (3) Great anim of wash crashing 2M +
 PP011/12 DATING GAME (2) Very witty! Get it 3.5M +
 PP016 GULF WAR Another ES production! Good 2M! Y
 PP021/24 LANDING (4) Tobias Richter poweranim 4M!
 PP025/27 STATION AT KHARN (3) Incredible 2M demo Y
 PP040/43 AT THE MOVIES II (4) Hilarious 11mp-3mg
 PP044/45 AMY V WALKER II (2) Another witty ES demo 3M
 PP046 SWEET REVENGE Coyote vs Roadrunner 1.5mg+ Y
 PP048/9 A DAY AT THE BEACH Stunning 1.2 Mg
 PP050 UNSPORTING Wicked animation by Schwartz 2M Y
 PP051/2 CHARLY CAT Super! Sharewartz cartoon! 2mg Y
 PP053/4 CHARLY CAT AT THE BEACH 2nd lab anim 2mg! Y
 PP055/6 APC MISSION Superb walker & tank battle 3mg!
 PP057/9 CHARLY CAT CATCHES A CANARY Fab! 3mg
 PP060/3 CHARLY CAT M0USTERMIND Great! 3.5MG
 PP064 DUNCAN DUNG BEETLE Unusual 2m animation! Y
 PP065/6 CHARLY CAT SNOWJIGGY Latest anim 2mg + Y
 PP067/9 SPEED LIMIT 3mg motorcycle race! + Y (3)

DEMOS

- PD005 AMOS 3D DEMO Shows some great effects! + Y
 PD018 CHAOS ROCK Fab light show with fractals! +
 PD068 PHENOMENA ENIGMA Absolutely brilliant! + Y
 PD076 PLASMAFLEX Good plasma & great music + Y
 PD094 S00PEE MENTAL HANGOVER A classic!
 PD097 SILENTS GLOBAL TRASH Incredible!
 PD130/34 ALCATRAZ ODDSSEY Awesome!!! Ok on 500+!
 PD139 TRACKERS POWER & AGONY Unusual vector! +
 PD142 FINAL CONFESSION Music & Plasma effects! +
 PD143 CAT Silents & Cronics demo for cat club +
 PD159 ANARCHY IN THE KITCHEN Some good FX Fab!
 PD162 ALGHEM MARCHWITH Very good new demo!
 PD164 DESIRE MEGADE Good Psycho riva demo + Y
 PD168 BOLD DEMON Mega new demo - get it! + Y
 PD170 PIECE OF MIND Good 3D vector effects. +
 PD171/2 SILENTS EXPOSED(2) Incredible Get it! + Y
 PD175 REFLECT SOUND VISION Super effects & music!
 PD176 CHAMELEON DEMO Very nice vector demo! + Y
 PD177/8 TRSI TIME ZONE New, some good effects! + Y

MUSIC DISKS

- PM001 100 GREATEST 64 TUNES 100 fab 64 tunes!
 PM010 AMEGA PARTY WINNERS FOUR WICKED songs+ Y
 PM012 AMIGADEUS CLASSICAL Eine Kleiner etc + Y

- PM013 ANARCHY CAPTURED IMAGINATION Nice music! +
 PM016 BEATLES SONIX Nice music + Y
 PM018 BEATMASTER I LOVE TECHNOLOGY Rave disk+ Y
 PM019 BRUNO'S MUSIC BOX II Superb jazz funk music+ Y
 PM020/21 BRUNOS MUSIC BOX III Jazzfunk. Get it + Y
 PM022/23 CLASSICAL MUSIC Bach, Handel etc! + Y
 PM027 D-MOB MUSIC 3 Concertos music remix, good! +
 PM030/34 DIGITAL HOUSEBOX 2-6 Excellent house/dance!
 PM035 DIGITAL DEBUSSY Fab Rob Baxter conversions! + Y
 PM038 DIGITAL DEBUSSY2 classic Debussy music! + Y
 PM058 MAG FIELDS CHIP FESTIVAL Full of chip music! + Y
 PM059 MANIACS OF NOISE This is brilliant!
 PM062/8/2b VIVALDI - FOUR SEASONS (2) V Good! + Y
 PM090/91 MOZART HORN CONCERTO 4 by H.Gammon+ Y
 PM092 PIANO TUNES Nine piano songs - good + Y
 PM096 STAIRWAY TO HEAVEN Rendition of the song+ Y
 PM105/6 KEFRENS MEGAMIX Fabulous dance music!
 PM114 UPROAD SPL! BEAVERS MIX rave megamix + Y
 PM115/6b CHROME Brilliant music disks! + Y
 PM121 NIGHTBROTHER MUSIC DEMO8 Rave music demo+ Y
 PM122/4 PLAYSID 2 (3) You must get this!!!! + Y
 PM125 PLAYSID inc Rob Hubbard, Maniacs/OnNoise + Y
 PM134/5 SOUNDS OF SCIENCE (2) Brilliant! + Y
 PM137 KEFRENS MEGAMIX II Very good!! If dance music!
 PM141 HARDLINE MUSIC 7 groovy synth-style tracks+ Y
 PM150 DESKTOP HARPISCHORD (2) Digital Classics! + Y
 PM152 PARADISE. NO BRAIN NO PAIN Good for ravers! + Y
 PM153 BIZE KILL DA BABE 6 tracks of rave music! + Y
 PM154 PULSE Yes, pulsating rave music again!! + Y
 PM155 VINE G-RAVE 5 more good rave tracks!!! + Y
 PM157/8 HEATBEAT UPDATE 9 great songs here! + Y
 PM159 DECIBEL OVERLOAD 5 different tunes! + Y
 PM160 FUSION MATRIX 5 rave type tracks! + Y
 PM161 CYBERMETIX 10 songs packed on 1 disk!
 PM162 MORE MED TUNES Fab tracks by Atax Starrex! + Y
 PM163 OCTASTUFF Some good 8 track tunes! + Y
 PM164 OCTAROCK 3D More 8 track & 3D graphics! + Y
 PM165/6 NUTCRACKER SUITE Super rendition! + Y

SLIDESHOWS

- PS002 ADVANCE HAM Really stunning 1+ Y
 PS008 AIRCRAFT SLIDE Pics of lighter aircraft! + Y
 PS009 ASTRONOMY SLIDE very impressive 1+ Y
 PS013 BORN TO BE FREE wild animals + Y
 PS033 GEMMY RAY TRACE Superb See these!
 PS045 KELLER S/S Some quality HAM pictures + Y
 PS056 NEWTEK DYNAMIC HAM 640x512 4096 color pics+
 PS062 NW DYNAMIC HAM Nik Williams Super quality+
 PS067 RICK PARK'S ART Dpaint time pics! + Y
 PS072 SUPER HAM CARS This is a must-MEGA! + Y
 PS086 SONIC 5 Superb D-HAM 4096 color pics+
 PS090 FRACTALGAIN Incredible fractals etc! + Y
 PS091/2 FRACTAL MOUNTAINS Excellent stuff! + Y
 PS093 VANISH 3D Awesome 3d ray traced + Y
 PS094 INVISIBLE WORLD II Yuk Bedbugs And more! + Y
 PS101 ANALOGUE SLIDE Ray traced space pics + Y
 PS102 ACCESS DESIGN Ray traced space pics + Y
 PS103 DYNAMIC HIRES 2, fantastic quality pictures!
 PS104 VAG PICS Some excellent quality pictures here! + Y
 PS105 SCAN PICS Excellent quality pictures! + Y
 PS106 BAHRAIN SLIDES Pics from the middle east!
 PS107 ALCATRAZ MUSEUM 18 super quality drawings!
 PS108 SANITY COMP WINNERS 10 Superb drawings! + Y

MUSIC UTILS

- PT001 ALGORITHMS Create weird midi tunes
 PT002 ART OF MED Excellent 1+ Y
 PT005 CASIO CX EDITOR 250 patches! + Y
 PT006 DELUXE MUSIC DATA Midi music+ Y
 PT009 KIFF SAMPLES Excellent quality samples + Y
 PT011 KAWAI K1 editor for patch changes!
 PT012 KAWAI K4 editor for satch changes!
 PT013 MED 3.2 Excellent music seq. + Y
 PT014 MED MUSIC DISK As it says 1+ Y
 PT015 MIDI DISK Various midi stuff +
 PT020 ST-01 - ST-10 Samples-Ring for details
 PT021 SOUNDTRACKER 2.6 Excellent, ok plus+ Y
 PT022 SOUNDTRACKER COMPILATION Several versions!
 PT025/7/8 ST-90-91 SAMPLES Superb quality+ Y
 PT029 YAMAHA DX7 VOICE FILER for DX7 synth!
 PT030 YAMAHA DX7 VOICE SORTER for the above!
 PT031/3/4 ST-87 - 89 3 disks full 1+ Y
 PT032/5 ST-91 & 98 More samples 1+ Y
 PT037 PROTRACKER 2.2 THE LATEST VERSION!
 PT038 YAMAHA DX100, TXB12, DX27, DX111 & FB01 editors
 PT040 OCTAMMED V3 8 channel MED sequencer!
 PT041 NOISEPLAYER 4.0 Multitasking module player +
 PT042 START IFF SAMPLES Superb! Get this disk! + Y
 PT043/5 HOUSE SAMPLES 3 disks full of house samples!

AMOS PD

- APD036 AMOS UPATER Latest update!!! v1.34 + Y
 APD115 BALDOPOLY Bomb the buildings! + Y
 APD237 SHAPES EXCELLENCE 144 game 1+ Y
 APD257 CASSETTE LABELLER - MIXED SOURCE+ Y
 APD271 WIZARDS DOMAIN graphical adventure+ Y
 APD292 WAR OF THE FOUR graphic adventure game+ Y
 APD329 FRUIT MACHINE Good for the gamblers! + Y
 APD347 NOTEBOOK & SHOPPING LIST Easy to use! + Y
 APD363 FAMILY HISTORY DATABASE Latest version! + Y
 APD373 COMPILER 1.34 UPDATE Amos compiler 1+

NEW!

- PU269 CONSTELLATION Demo of shareware program! + Y
 PU270 STARGATE Easy to use catalogue maker! + Y
 PU271 CLUMPY ICONS A disk crammed with icons+ Y
 PU272 GOLF RECORDER Database for golf scores! + Y
 PU273 PC-to-AMIGA Similar to Mavesys, + docs! + Y
 PU274 TRANSCRIB V1.0 Electronic circuit design! + Y
 PU275 FLIT Convert Autodesk anims to IFF+
 PU276 BBBS A Bulletin board system! + Y
 PU277 PROTEUS BBS Another comms program! + Y
 PU281/9 CLASH OF THE EMPIRES Super strategy! + Y
 PE025 FRACTIONS & SILHOUETTES Good maths tutor + Y
 PE026 WW II FACTS Good historical program! + Y
 PE027 AMOS BEGINNER Learn to use your machine + Y
 PE029/80 HALF BRAINS SUNSTORM Very good demot!
 PM167/8 JESUS ON ES Crazy rave music demo! (2)
 PS109 NAM VIETNAM Black & white slides! + Y
 PS110 MIRAGE FORGOTTEN PICS Nice pictures! + Y

ORDERING MADE EASY

BY POST: send your Name, Address & Order details with a Cheque /PO /IMO to any of the companies listed
 BY PHONE: Call us with your card number and details for a 1st class service. All major cards accepted
 PD PRICES: 1 - 5 disks £2.00 per disk - 6 - 25 disks £1.25 per disk - 26 or more disk are still only 99p per disk!
 POST & PACKING: UK - 50p + UK "Recorded Delivery" £1.00 + Europe +25p per disk - Rest of World +50p per disk
 REMEMBER: We stock Fish 1-760, Thag 1-63, Amos, Scope, Snag, Amicus, Amigos & lots more superb PD disks!!

PLEASE NOTE:
 All disks on the advert should work on the Amiga 1.2/1.3
 dos systems unless otherwise stated. All disks with a "Y"
 sign should work on the Amiga 500+ & 600 machines!
 However there are so many different setups now in use it
 is becoming impossible to test for every possible variation,
 so please use some caution when purchasing, especially with
 various dos systems, CD/DVD and of course the new
 Amiga 1200 & 4000 systems. Disks marked with a "Y"
 should be okay on the A1200 /4000 (though obviously not
 yet extensively tested. Please take care!

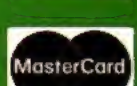
main Distributors

not the imitators!

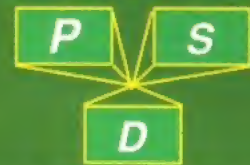

MEMBERS OF THE PROFESSIONAL STANDARDS OF DISTRIBUTION

New .. The Central Licenseware Register .. New

Commercial Quality programs at a PD price!



CLE01 TOTAL CONCEPTS DINOSAURS Have your children ever wanted to know about the ancient world of the dinosaur? If so, then this is for you - an interactive encyclopedia covering Jurassic, Triassic & Cretaceous periods complete with pictures and information. This program is plus compatible and comes on 2 Disks. £4.50 -



CLE02 TOTAL CONCEPTS GEOLOGY This title is the second in the series of quality programs by Chris Hill, using the GoldDisk Hyperbook system, it will guide you and your children on an interactive guided tour through the incredible world of volcanoes, rocks and minerals. The program is very simple to use! GeoLOGY is on 2 Disks £4.50 -



CLE03 TOTAL CONCEPTS SOLAR SYSTEM Now our most popular title! This one invites you to learn all about the solar system, with information on all of the planets & systems with pictures supplied by NASA, this is a superb educational package for children & adults. This title is so big it is supplied on Three disks and is priced at only £4.99 -



CLE04 KIDDIES COLOURING PAD This is a colouring book for young children and they won't get in a mess using it! It is very simple to use with full instructions with the program. Simply pick a picture and colour it in! Includes a save option, so once you have coloured your picture you can save it out to a disk to print out using DPaint etc. Price £3.50 -



CLE05 A-CHORD So you want become the next Eric Clapton then this is just what you need! This program will teach you nearly every single guitar chord including fingering techniques, it will even play the chords using the Amigas built in sound chip. A must for every single guitar player beginner and experts alike. Price £3.50 -

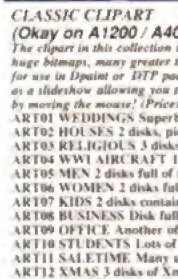

CLE06 THE AMOS MATHS INSTRUCTOR, A superb maths tutorial covering all sorts of mathematical subjects including trig, Quadratic, Simultaneous, Inequalities, Volumes, Area, Vat & Interest and more, an excellent aid for GCSE students. Price £3.50 -

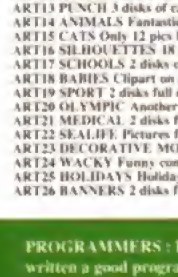

CLE07 TOTAL CONCEPTS FRESHWATER FISHING The latest in the series from Chris Hill, and the first in the hobbyist series, this superb title describes baiting Perch, Roach, Rudd, Carp, Bream & many other common freshwater fish. Ideal for the beginner or the hobbyist with many useful diagrams included! A superb title, on 1 disk Price 3.50-

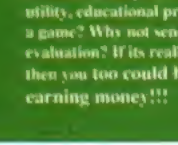

CLE08 NIGHT SKY A superb introduction to the constellations, this program features over 1500 stars, and the sun moon stars & planets can be displayed as seen from any part of the Earth! Large scrolling screen, mouse or keyboard controlled, click on any displayed object for information. This superb title Comes on 1 disk & is priced at 3.50!



CLE09 WORDS & LADDERS An excellent spelling program for 1 or 2 players, each player has a few seconds to spell a word correctly, the player who reaches the top of the ladder is the winner. The program has 10,000 words so some words can be quite long, however you can select the level! Will also provide printed output to a connected printer. 3.50!



CLE10 BASICALLY AMIGA This is a 3 disk set for the new user! An extensive guide through the use of Amigados. Covering Hardware, Software, Graphics, Sound, the Workbench, Viruses and much much more you will soon wonder how you did without this useful utility pack! For young and old users alike 3 disk set priced at 4.99! -



CLE11 LET'S LEARN V1 1 For children of about 5 to 7 years of age, each part progresses through five levels of difficulty, when a level is satisfactorily completed then a picture of a farmyard is displayed & a new animal introduced! Try Sums, Tunes, Codes, (numbers), Opposites & Squares! The program also has a print option! 1 disk 3.50 -

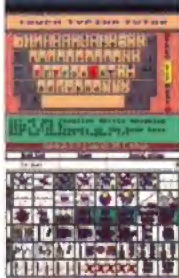

CLU01 VIDEO TITLER is a program that will allow you to create smooth scrolling video titles with the greatest of ease, programmed by Darren Mccaul, whose Starbase is due out soon, the program lets you use any Amiga bitmap font, of which several are supplied, and scroll in any colour vertically up the screen. Essential for all video enthusiasts! £3.50 -



CLU02 FISH INDEXER If you have ever wanted a program, but have never been able to find it ANYWHERE chances are it's probably in the fish library, but rather than having to rake through thousands of lines of text, why not use the Fish Indexer, a superb database of the entire Fred Fish library, with full search, print and more. Price £3.50 -



CLU03 TYPING TUTOR A program here now for all you budding office clerks, learning to type can be a real pain, lessons cost a fortune, but not when you have an Amiga! This program will take you step by step through a full typing course, showing where to place your fingers and lots more. Before long you'll be able to type as fast as I can! Price £3.50 -



CLU04 ALPHA GRAPH This is an extremely useful program for the production of pie charts, bar charts, Block scatter etc, very useful in conjunction with spreadsheets & other business programs, this program comes on one disk and is priced at 3.50!



CLU06 SUPER SOUND III This is a superb program which can manipulate samples in almost any way you please, special effects such as reverb, tremolo, phasing, phanging, echo are just a few of the things which are easily accomplished, the equal of expensive commercial software! Price 3.50!

CLU10 POWER ACCOUNTS This is an accounting package for keeping check on your bank account, and is capable of generating account statements and income & expenditure reports. The program will also allow you to "password protect" your data files! An invaluable program for all of your finances, comes on 1 disk, price 3.50 -

CLU11 CALC V1 3 A nice spreadsheet program which works on any Amiga! A spreadsheet is an electronic version of the traditional method of performing complex calculations using rows & columns of figures. In the same way a wordprocessor allows rearranging & editing before printing, so a spreadsheet allows figures & calculations to be constantly changed! 3.50 -



CLU12 VIRTUAL WINDOWS V1.0 Collectively a suite of very useful programs, all on one disk! Features Notepad, Address book, Desk diary, Software VMS inventory & an Amigados survival guide. All can be accessed from a menu system with the mouse & are very easy to use. Price 3.50 -

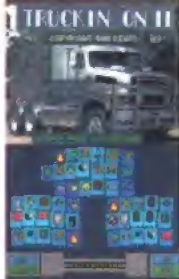

CLU13 DATOS A powerful easy to use database with many features, audible tone, keyboard/mouse control, template feature, cut & paste with mouse, help features, rearrange/add fields even after creation, warning messages, can print down or across the page to save paper, many more features too numerous to list. Price 3.50 -



CLG05 TRUCKIN' ON This is a new version of a PD game that was originally bugged to hell, the programmer has taken all the main elements of the game and re-programmed it in C, so it's now fully playable truck driving simulation and management program. TO is a must for all you truckers out there and is supplied on 2 disks & needs 2 drives! 4.50



CLG08 DRAGON TILES This is an excellent puzzle game you have a huge stack of different icons which, using the mouse you must match up to make a level disappear, sounds boring but it's actually very addictive. I was playing it for hours! A vast improvement on the PD version, Dragon tiles is well worth anyone's couple of quid! Price £3.50 -



CLG09 MOTOR DUEL Now this is just fabulous! Martin would not leave this game alone for days, it's a 3D car racing-chasing-shooting game, with guided missiles and lasers, it's by the same programmer as the PD game Battlecars, but it's a lot better, play the computer (Mega difficult) or link up to another Amiga for 1 on 1 action! Price £3.50 -

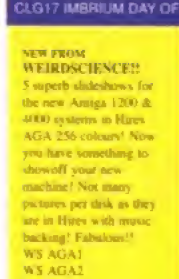

CLG011 ALL GUNS BLAZING This is a two player car racing game viewed from overhead. You can also blast the other player's car with missiles, lay mines, oil slicks and smoke. There is also a facility to design your own tracks to your own satisfaction. Price 3.50!

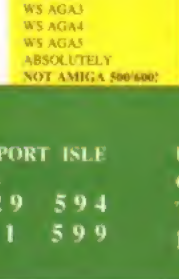

CLG012 BULLDOZER BOB The object of the game is to clear the screen of coloured blocks by pushing them together. Once they touch they disappear! You have a limited number of moves to clear the screen, and the difficulty increases with each level. This is definitely a game for puzzle fans! Price 3.50! -

CLG013 PARADOX Yes - another good puzzle game, similar to Bulldozer Bob, but Mr Cool head is doing all the pushing! Push the coloured balls till they touch & disappear! There is a time limit for each screen & a variety of objects to collect but beware of traps! Very addictive game. 100 levels of gameplay! Price 3.50! -

CLG015 SPLODGE THE ESCAPE Great platform game. Spodge was going on holiday to Ganymede when the spacebus on which he was travelling was hijacked by Big hairy monsters! He was imprisoned in an old house behind a Rongarf spaceport building! You must guide Spodge, solving puzzles & collecting coins to buy a ticket home to Jupiter. Price 3.50 -

MORE CLR TITLES ALSO AVAILABLE:
 CLU08 WORD FINDER crossword & anagram solver & dictionary! 2 disks 4.50 -
 CLU09 PLAY & RAVE2 Music module linker, create your own tunes! 2 disks 4.50 -
 CLG01 NORRIS A medieval romp across many levels! very addictive! 1 disk 3.50 -
 CLG02 DARK THINGS Another scrolly run & jump platform game! 1 disk 3.50 -
 CLG03 PHASE II This is a sideways scrolling shoot 'em up, 1 disk 3.50 -
 CLG04 X-SYSTEM Multilevel shoot up, blast end of level monsters! 1 disk 3.50 -
 CLG14 SONIC SMARTIEHEAD Platform game for 8 years & over! 1 disk 3.50 -
 CLG17 IMBRIUM DAY OF RECKONING Excellent graphic adventure! 1 disk 3.50 -

NEW FROM WEIRDSCIENCE!
 5 superb slideshows for the new Amiga 1200 & 4000 systems in Hires AGA 256 colours! Now you have something to show off your new machine! Not many pictures per disk as they are in Hires with music backing! Fabulous!!
 WS AGA1
 WS AGA2
 WS AGA3
 WS AGA4
 WS AGA5
 ABSOLUTELY NOT AMIGA 500/400!

FUNPACK GAMES
 A HUGE COLLECTION OF PD GAMES ON 30 DISKS, ALL A500+800 COMPATIBLE - A MUST FOR THE KIDS! (MOST OK ON A1200)
All 30 for Only £29.95!

ASSASSINS GAMES
 THE ULTIMATE COLLECTION OF GAMES FOR THE AMIGA, ALL THE GAMES IN THIS PACK ARE THE BEST AVAILABLE, NEARLY EVERY GAME YOU CAN THINK OF INCLUDING PACMAN, INVADERS, GALAXIANS, ASTEROIDS, CARD GAMES, TETRIS, PUZZLE GAMES, WELL OVER 130 GAMES IN TOTAL - PACKED ONTO AN AMAZING 35 DISKS! (Smaller packs on request)
All 35 for Only £34.95!
 PHONE FOR A500+800 COMPATIBILITY

PROGRAMMERS: Have you written a good program, be a utility, educational program or a game? Why not send it in for evaluation? If it's really good, then you too could be earning money!!!

BLITTERCHIPS
 UF12 CLIFFE HOUSE, PRIMROSE STREET, KEIGHLEY, BD21 4NB.
 TEL: 0535 667 469
 FAX: 0535 667 469

NBS
 UF12 ICHAIN LANE NEWPORT ISLE OF WIGHT PO30 5QA
 TEL: 0983 529 594
 FAX: 0983 821 599

VALLY PD
 UF12 PO BOX 15, PETERLEE CO. DURHAM SR8 1NZ
 TEL: 091 587 1195
 FAX: 091 587 1195

ALL DISKS NOW
ONLY
£1.05 EACH!

(All disks work,
with the A1200!
unless stated)

Anglia PD

Catalogue Disk (P)
only 70p - Includes a
superb Scenery
Generator!

(P) = Works on A500, A500 Plus and A600

HOME MANAGEMENT PACK 3 DISKS (P) £3.15
Calendar, Mortgage, Spreadsheet, Grammar, Mileage, World Time, Budget, Chequebook, Database, Typing Tutor, Typewriters, Grocery, List Maker, Home Banking

CLIPART PACKS 1, 2 OR 3 EACH PACK = 5 DISKS £5.25
3 different packs of 5 disks, all full of the very best clipart for DPaint etc. (P)

FONTS PACK 1 OR 2 EACH PACK = 5 DISKS £5.25
2 different packs of 5 disks, pack 1 contains: Publisher fonts, various fonts, fonts disk 2, Cosmopolitan fonts, large fonts (loads of great fonts for DPaint etc.) (P)

ANGLIA COLOUR FONTS PACK 1 OR 2 (P) 5 DISKS £5.25
5 disks full of original colour fonts produced here at Anglia. There are 16 colour fonts - not cut and paste! They are produced in the same way as the chisel font supplied with DPaint and the Kale range of commercial fonts. They are typed straight in and work with Dpaint and TV Text.

EDUCATION PACK 1 (P) 5 DISKS £5.25
German, Globe, Geotime, Drawmap, Evolution, Clouds, Formula, Artlab, Gravity Sim, Weather, Wave Maker and more! (This pack is one of our best sellers and is incredible value for money)

ASTRONOMY PACK (P) 4 DISKS £4.20
This superb pack now includes: Star Chart, Amigazer, Total Concepts, Astronomy, Gravity Well, Grav Sim, Orbit, Planet and Fast Facts on the solar system.

PRINTER USER PACK 2 (P) (NEW) 4 DISKS £4.20
A completely new collection of programs to help you get the best out of your printer! Includes: Diskprint V3.51 (Disk labels), MCMaster (Cassette covers), Printfiles, JBSPool, Envprint (Envelopes), New Print (Margins - Headers Footers etc.) and more.

SIMULATIONS PACK (P) 5 DISKS (Not A1200) £5.25
All the PD Simulations in one pack: Metro, King Of, Nuke, Impulsion, Sealance, Truckin, DC10, Conquest, Insiders Club, Air Warior

EASY BUSINESS PACK (P) 5 DISKS £5.25
All programs included are powerful but easy! Includes: Text Engine V3 (The very latest wordprocessor), Spread V1 (Spreadsheets), QBase (Simple Database), BBase II (Good Database), Banker (Great accounts packages), X-Spell (Spell checker), Print Studio

INTERMEDIATE BUSINESS PACK (P) 5 DISKS £5.25
Wordwright (Wordprocessor including Mail Merge and Macros), S-Calc (Good Spreadsheets), Amibase Pro 2 (Slunning RD Database - New!), Amigaspell (Spell Checker), LS Label (Infinite label control), Messyid V2 (Amiga File Management - PC File Transfer), Amiga Fax (Desktop Publishing)

DISK EXPERT PACK (P) 5 DISKS £5.25
If you want to learn more about your Amiga, get this pack! - You'll be a disk expert in no time! Includes Power Packer (Easy file compactor), Sid (Brilliant CU Replacement Tool), Iconmania (Change any icon in seconds), Fixdisk, Viruschecker V5.3, D-Copy (Copies, Repairs, Formats and more), CU Tutorial (All you need to know) and 202 other utilities!!!

"C" PROGRAMMERS PACK (P) 6 DISKS £6.30
A complete "C" language and superb instruction manual provide all you need to learn the "C" language, includes North C (3 disks) and the C Manual (4 disks)

MED V3.21 MUSIC PACK (P) 4 DISKS £4.20
MED is widely recognised as the best music package, PD or

otherwise! This pack contains V3.21, the latest version complete with loads of digital samples, a disk full of MED music scores and some great MED music to load and play! Listen to what your machine is capable of!

500+ CLASSIC GAMES PACK (P) 5 DISKS £5.25
An incredible collection of superb commercial quality arcade games! Hours of fun for both kids and adults. Includes: Defender, Galaxians, Scramble, Missile Command, Pac-Man, B-Planes, Droid, Snake Invader, Asteroids, Breakout, Tetris - more!

CARD & BOARD GAMES 2 (P) 4 DISKS £4.20
Another outstanding collection! 38 very good "Thinking" Games! Chess V2, Backgammon, Blackbox, Towers, Ape, Zerg, Maze, Connect4, Dominoes, Draughts, Othello, Go Monk, Dragon Tiles, Klondike, Canfield, Mastermind, Wordsearch, Hangman, Rantoon and many more.

PUZZLES PACK 3 (P) 3 DISKS £3.15
6 brand new graphical puzzle games, all brilliantly done, guaranteed to keep you playing! Ashido, Flag Catcher, Roberto, Quadrix, Paragon, Technoban

PC EMULATOR PACK (P) (NEW!) 3 DISKS £3.15
Includes the incredible PC Task CGA Emulator and two disks full of PC Public Domain Software

C MANUAL V3 53 PACK (P) (NEW!) 5 DISKS £5.25
The Amiga C Encyclopedia consists of six manuals with more than 40 chapters, 175 fully-executable examples, utilities and other goodies. It all adds up to a complete work on how to program in C on the Amiga. Expands onto 12 disks!

C MANUAL V3 DE-CRUNCHED! (P) 12 DISKS £12.60
HARD DISK PACK 2 (P) 3 DISKS £3.15
Great collection of the latest hard disk utilities includes HDClck (Menu maker), Fileminia (directory etc.), a backup (superb), superio (password protect over drive, mouse and keyboard), disk optimizer, copier, virus killer and more!

SHOOT 'EM UP PACK (P) 5 DISKS £5.25
The finest blasting games in PD! Includes: Garage 92, Revenge, Invader Alert, Blitzard, Tom Cat, Moonbase and Hellzone.

SINGLE DISKS AT ONLY £1.05!

BUSINESS
8301 (P) (85%) AmigaFax (English Desk Top Publishing)
8309 (P) (95%) 600 Business Letters (Superb! - Ready to use.)
8330 (P) (80%) Amicash (Superb new bank account manager)
8331 (P) (90%) QED (Very good wordprocessor for beginners)
8332 (P) (90%) U-Edit V3 GA (Latest and greatest word pro)
8333 (P) (86%) Amibase Professional 2 (Now PD - Super database)
8335 (P) (99%) Forms unlimited II (Design invoices etc. quickly)
8339 (P) A-Graph (Produce Bar + Line Graphs easily)
8392 (P) (80%) Text Engine V3.4 (great looking wordprocessor)
8340 (P) (85%) Bbase II V5.5 (Latest Database now includes better printouts and mailing labels)
8348 (P) (New!) Wordpower (Great spell checker with crossword and anagram solving tool)
8344 (P) (NEW!) The Money Program (Very nice accounts package)
8345 (P) (NEW!) Amigadesk (easy to use card file address book)

UTILITIES
LM16 (P) (70%) C3 Tutorial (Learn all about it)
LM37 (P) (95%) D-Copy V2 (Now an even better disk copier)
LM78 (P) Typing Tutor (New! Great features.)
LM95 (97%) Viruschecker V5.15 (P) (The best for the plus tool)
LM96 (P) (95%) Messyid V2 (Reads and writes PC disks)
LM97 (P) (95%) A500+ Utilities (For the A500+ only)

LM04 (P) (NEW!) Rools Predictor (It's back! 1995 season)
LM07 (P) (93%) Disk Optimiser (Fast disks, DHD Tool)
LM09 (P) Amiga Tutorial (A beginners manual on disk, superb!)
LM018 (P) (New!) Clips (100% full of structured clipart for Regestrem, Pro Page etc!)

LM092 (P) Opticomms 2 (Includes ncomm V2)
LM093 (P) (NEW!) Main Event (Set your amiga to perform many tasks by itself, at any time!)

LM094 (P) A64 Emulator (3 disks - C64 Emulator)
LM095 (P) (94%) PC->Amiga (Transfer files and much more - superb)
LM096 (P) Superkillers 2 (All the best virus killers on one disk)
LM097 (P) (NEW!) Inscript (The finest video titler yet seen - incredible features - very professional!)

GAMES
G6019 (P) A500+ Games (37 Games for the Plus!)

G6027 (P) (91%) Lorian (Superb ultima type adventure - great graphics - hordes of monsters) (NEW)
G6035 (P) (NEW) Klaxons (Superb "Columns" game!)
G6036 (P) (NEW) (92%) Total War (Perfect version of The Risk board game)
G6039 (P) (NEW) Last Refuge (A shoot-em-up by Fred fish!!!)

G6040 (P) (NEW) Revolution (Puzzle game - also 2 player tanks!)

G6041 (P) (NEW) Octothello (8 sided othello plays a mean game)
G6042 (P) (NEW) Super Pacman 92 (Easily commercial standard!)

G6043 (P) Blackjack (Casino pontoon, loads of options)
G6044 (P) (82%) Amos Bingo (Bingo the numbers - Amiga calls)
G6045 (P) (88%) Amos Cricket (The best PD cricket game)
G6046 (P) Amos Fruit Machine II (More features than ever!)
G6047 (P) Dr Mario (The classic console game)

CHILDRENS
C712 (P) Colour Pad (New colouring book for youngsters)
C714 (94%) Starland II (Brilliant kids game)
C719 (P) (87%) Total Concepts (3 Disks) (Astronomy & Dinosaur Education Pack - Good!)
C720 (P) Colour the alphabet (Great education for early learners Ays+)

C724 (P) (95%) Doodly (Like Mario Bros and very good - NEW!)
C725 (P) (91%) Mr. Mrs. (Platform adventure for 7yrs+ - it's got everything!)

C726 (P) (83%) GCSE Maths (Great revision disk)
C727 (P) (100%) Top Secret (Reviewed as the best platform game ever!!)

C729 (P) (100%) Maths Reflex (practice basic arithmetic ages 5 to adult)

C729 (P) (NEW) Counting Fun (For age 4+, Excellent simple arithmetic practice)

C730 (P) Wizzys Quest (Wizard, Daniel + Monsters, great game!)

C731 (P) (NEW) Willy in the Castle (Professional platform game)
C732 (P) (NEW) Fractions (Excellent fractions tutor)



DESKTOP VIDEO PACK 2 (P) (100%) 4 DISKS £4.20
Probably our best pack yet! Provides everything to start you off in video. 5 Movie for smooth scrolling titles using any font of any size. Showit for slideshows with loads of wipes and fades. A-Graph for business videos. Shadow Maker to add shadows and smooth any font. Video Librarian. Video Tools. Video Tests. Loads of fonts and more!

DESKTOP VIDEO PACK 2 INSTRUCTION MANUAL!!! (P) £2.99
A 50 page instruction manual for DTV pack 2. Professionally printed, contains instructions for all the programs in the pack and a section on fonts and how to use them! Also includes a superb guided tutorial that takes you through the major programs step by step, letting you create your own titles as you go! Designed for beginners and experienced users, this manual will make desktop video easy!

FISH DISKS IN STOCK 350-750 ONLY £1.05 EACH!

DEJA VU "I-LATEST" £3.99 EACH!

HIGH QUALITY HARDWARE
8mm High Quality Mouse Pad £2.99
Amiga 500/500+ Dust Cover £3.99
Monitor/TV Dust Cover £4.99
3.5" Disk Drive Cleaning Kit £2.99
2 Piece Printer Stand (Paper under) £5.60

ANGLIA PUBLIC DOMAIN LIBRARY
(Dept AMF), 115 Raneagh Road, Felixstowe, Suffolk, IP11 7HU

Access VISA CREDIT CARD ORDERS

International orders welcome but please add 30p per disk for post & packing.

PHONE 0394 283 494

PUBLIC DOMAIN SOFTWARE

- ◆ We have 3,000 PD disks for your Amiga, from serious applications to demos & games.
- ◆ We can supply most of the programs & demos featured in this magazine.
- ◆ We have been distributing PD for the Amiga since 1988 and have 1,000s of satisfied customers.

5 DISK PACKS Each pack has 5 disks of the best PD software

- ◆ BUSINESS PACK
- ◆ KID'S EDUCATION
- ◆ ARCADE CLASSICS
- ◆ CLIP ART
- ◆ ESSENTIAL UTILITIES
- ◆ BOARD GAMES

£7.95 per pack

100 GAMES
£34.99 post free
Superb collection of the best available games.

This compilation contains 100 of the best PD/Shareware games & includes arcade games, sports sims, adventures, board games, puzzles etc.

FREE CATALOGUE
To obtain one, send an SAE or 2 Stamps.

KINGSWAY COMPUTERS

72 GLENCOE RD, SHEFFIELD S2 2SR
TEL (0742) 750623

MasterCard VISA

Educational Software



The Connoisseur's Choice

If you are looking for software to help with the National Curriculum, then look no further. Our new free catalogue is packed with programs suitable for all ages from six to adult on a wide range of educational and leisure subjects.

Write or telephone for our new FREE 16-page colour brochure of Educational and Leisure software (Please state computer type)

- Subjects now available include ...
- | | | |
|---------|---------------|-------------------|
| Maths | Science | Arithmetic |
| French | Geography | Football |
| German | History | Sport |
| Spanish | English Words | First Aid |
| Italian | Spelling | General Knowledge |

Kosmos Software Ltd, FREEPOST (no stamp needed)
DUNSTABLE, Beds. LU5 6BR
Telephone 0525 873942 or 875406

UK producers of educational software since 1983

BARKMAN COMPUTERS

READ THIS!

The premier retailer of computer software and hardware for business & leisure.

HUGE stocks of SEGA & NINTENDO

Monitors, printers, Soundcards, Joysticks, Cables, Control Pads, Philips CDI, Amplifiers, Battery Packs, Action Replay, Carry Cases, Books, Magazines, Educational Software, Canon Bubblejet & more games than you could ever play!

Visit one of our stores at:-

30 High Street, Kingston Upon Thames, Surrey KT1 1HL 081 546 5941

Waterglade Centre, Ealing Broadway, London W5 2JN 081 840 2048

NEW STORE NOW OPEN

WACKO METAMORPH
DEMO
DELTRAX

The best bit about this animation is that it doesn't involve 'Wacko Jacko' anywhere. Oh, what a giveaway.



A fascinating demo, featuring the good part of Michael Jackson's *Black and White* video – you know, the bit with loads of heads morphing into each other.

An inspired piece of animation which demonstrates the power of morphing at its best, nicely converted in monochrome to the Amiga.

As an added bonus the demo is completely silent, which is bad for MJ fans, but a blessing for the rest of us. Excellent.

JESUS ON E'S
DEMO
**NBS,
DISKS 13/D9 & 10**

Wow! Hey! Freakout! And other such terms which the young ravers of today use (honest)... *Jesus on E's* is an incredibly long megademo, featuring flashy graphics synchronised to a powerful rave-style soundtrack.

This type of demo has become quite popular lately, with the releases by *Extensors* and *Wildfire* reviewed in Issue 41, but this release by LSD beats them all hands down. They have managed to squeeze about 10 minutes' worth of wild music and graphics on to two



HI TO MAFF, CLARE, SARAH, ALYN, STE, BRAINS, STEVIE, JANINE, H AND BIFFA.

Cut out the area above, make it into a loop with some Sellotape, then rotate it between your fingers. You now have an instant, Public-Domain scrolly greeting! Also, you could try moving it up and down for added effect. On with the demos...



Lots of interesting animations abound here, like this one of the Utah Saints – other clips include *The Wall*...

disks, and this includes several pieces of digitised and retouched graphics. Also among the mish-mash of graphics are good examples of solid vectors, hand-drawn stills and some rather excellent animated full-screen images.

If you're into rave, then take a look at the current Amiga rave demo scene – and this is far and away the

best yet. Not for the God-fearing, or for epilepsy sufferers, but great for everyone else.

**VOYAGE
CYNOSTIC PD**
DEMO

The Walker stands atop a small hill in a parallax-scrolling backdrop. Not sure who'd plant a tree up there, mind...

Continued overleaf

THE AD
CRAIG COLLINS
(3 DISKS - NEEDS 3 MEG)

Now famous for his *Dolphin Dreams* and *Speed Limit* anims, featured in Issues 40 and 41, Craig Collins has now come up with *The Ad*. This is another futuristic animation in the *Imagine*-rendered style of *Speed Limit*, and is set in the middle of the Kola Wars in deep space.

The beginning shows a spaceman busy welding a panel on a space station, while wearing a backpack advertising Koka Kola. He looks up and sees an advert for Real Kola, and decides to have a



Our man's busy at work welding part of the hull of a space station – when he sees a Real Kola ad...

quick drink. After floating up to a passing ship he drops off on to a ship advertising Pep-C. The Kola Kops then spot him and follow him, creating a superb chase sequence. He grabs on to a passing taxi cab, then drops off at a Tup Water machine – where he eventually gets his drink. The style is similar to the famous 'Lady loves Milk Tray' ads.

Incidentally, the author mentions the problems with adding sound effects to anims, namely the large amount of memory this would take up. This is



...so he sets off to try and find some real refreshment. Here he spots some Kola Kops approaching...

a good point, but when you're using three meg of memory for the graphics, another 100-200K wouldn't really be a problem for sound. Anyway, that's just a thought.

The Ad is an improvement over *Speed Limit* – much clearer rendering, although the brightness factor could do with being upped slightly – and a more easily understood storyline. Craig Collins is turning out to be one of the best technical animators on the Amiga – Tobias Richter, watch out...



...and in a white-knuckle ride through space, he has to duck and dive to avoid the laser fire.



DESERT DO-DOO

NBS, 13/A25

Excellent! The recent surge of young talent in the world of Amiga animation continues with this work by Andrew Shephard. Although he's produced a couple of anims before, under the title Robotic Antics, this is the first piece of his work to be seen here at *Amiga Format*.

Do-Doo is a character who's stranded 'somewhere in the Sahara Desert', poor little lad. Wearing nothing but standard desertware - sandals, shorts and a towel on his head, he wanders the sandy



Do-Doo merrily treks around the desert, taking in a bit of sun and generally enjoying the atmosphere...

planes looking for civilisation - eventually dropping to his knees from sheer exhaustion. The civilisation he discovers in this case is an ice-cream van (which are, apparently, quite common in the Sahara), containing a lot of ice cream and a lusty young lady.

She asks Do-Doo what he would like in a nice (Schwartz-esque) voice, and he relies "99, please." This is a cue for the final scene of the anim, which is quite a surprise - and you'll have to get the demo



By now he realises that holidays aren't all they're cracked up to be - terrible food and undrinkable water.

to find out what it is. So what's so different about this animator that he warrants a mention in Demo Zone? He's just 12 years old, that's what. When you see this anim it's difficult to believe it was created by someone so young - nice one Andy.

After Craig Collins, Roddy McMillan and Hugh Grove appearing in the past few months, yet another talented animator arrives on the scene. The future of Amiga animations just looks rosier and rosier, don't you agree?



The lusty decadent delights of Mr Whippy await our hero, but in decidedly odd quantities.

Ah, back to the original megademo format of a nice set of wholesome Amiga tunes from Razor 1911. Along with the music comes several scenes of animated graphics, including some excellent filled-polygon space scenes. A huge *Star Wars*-type walker strides about a parallax-scrolling landscape one minute and then you have a rather large ship flying around in deep space.

Another clever sequence is a spinning floor, on to which hundreds of shiny metal balls are dropped. They bounce around realistically for a while, before being sucked up in whirlwind-fashion. The presentation is superb, with particular attention paid to the way the characters are drawn.

A well put together demo, using some very clever routines. Worth getting.

AUDIO-X
CYNOSTIC PD,
DISK S00002

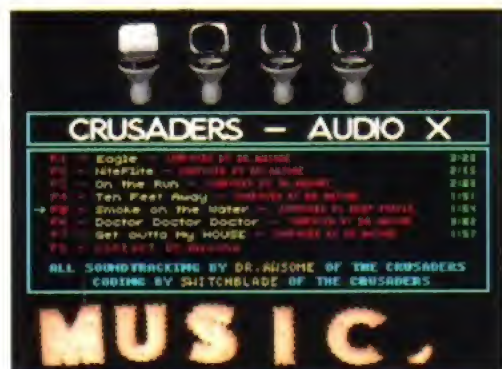

Bjorn A Lynne (aka Dr Awesome) prepares his stunning rendition of Handel's Toilet Water Music...

Bjorn A Lynne (of recent *hOBbItS* & *SpACesHips* CD and *Space Wars* video fame) wrote this collection of tunes, using internal Amiga IFF samples. Although it's not quite up to the standard of those two (they also used MIDI instruments), it is very nicely done. Not only is the music excellent, but the introduction screen is nothing short of brilliant.

The middle of the screen is taken up with the music titles - seven different tunes, including a bizarre version of *Smoke on the Water* by Deep Purple. At the top of the screen four toilets flap their lids in time with the music - one seat for each channel. A brilliantly surreal idea, very well done.

At the bottom the obligatory message scrolls past with greetings etc for other coders, but each letter of the font used looks like a shaped biscuit - very nice (no pun intended). Switchblade have done particularly well here, as have Crusaders.

THE SORCEROR

NBS, DISKS
13/A10,11,12 & 13



The Sorcerer, having morphed from his original state, realises that being a dragon can have its good points...

A good four-disk animation courtesy of Anthony Carpendale, which shows the story of a sorcerer who's been turned into a dragon. The sorcerer is first shown standing near the edge of a valley, waving his staff in the air. The thunderstorm begins, and a lightning bolt strikes our man - this is where the fun begins.

Obviously some god or other upstairs has decided that the man should grow some scales, and he begins to transform into a dragon. This is achieved using a couple of reasonable morphing effects created using *Deluxe Paint IV*. The graphics are generally pretty good, although they do look a little bit on the scruffy

side - they could do with a bit of tidying up, but this is only a minor point.

A big problem with this anim is that each scene is loaded separately from disk, and this spoils the continuity of the story. Although the swap disk screens are imaginative, the program should really look for the next disk in the second disk drive. As it is, the program recognises two drives, but only after clicking the mouse button. Maybe it's time that animators provided the facility to easily install their anims on to hard drives - after all, many serious users own them.

TOP TEN DEMOS OF THE MONTH

Just so that you know what's up and what's down we get a Public Domain library to give us what their top-selling disks of the month are...

NBS

1	Analog:Falling Up	D779
2	Piece of Mind	D789
3	Odyssey	PD130-134
4	Linus	PD166
5	RSI:Time Zone	PD177-178
6	Digital:Chameleon	PD176
7	Dolphin Dreams	PA101
8	Sonic the Hedgehog (Not Plus)	13/D6
9	Alcatraz:Museum	PS107
10	Jesus on E's	13/D9-10

WHERE TO GET THE DISKS IN THIS ISSUE

CYNOSTIC PD: 85 Wyken Croft, Coventry, CV2 3AD. 0203 613 817

DELTRAX: 36 Bodelwyddan Avenue, Old Colwyn, Clwyd, LL29 9NP. 0492 515 981



CRAIG COLLINS: 25 Jubilee Avenue, Normanton, West Yorks, WF6 1DW.

NBS: 1 Chain Lane, Newport, Isle Of Wight, PO33 2QQ. 0983 529 594

The Tipster[©]

- The worlds best selling Horse racing software
- Uses information from daily newspapers
- National Hunt, Flat and Dirt
- Available in your local software shop
- "At the price, no self respecting punter can afford to be without it". (*Amiga Format*)
- "A nice little earner". (*Amiga Computing*)

Tipster is available in two versions, costing £29.95 each. The *International* version is for use with daily newspapers while the *Professional* is for use with *The Racing Post*. Please phone for a demo disk (£9.95 refundable) which also contains *The Punter* (Pools), *The Dogs* (Greyhounds) and *The Bookie* (Odds Calculator).

 **£29.95** inc VAT 

Sidmouth Software
 PO BOX 7, SIDMOUTH, DEVON EX10 0TD
 TELEPHONE 0395 67073



DATAPLEX COMPUTERS LTD.

129 Bath Road,
 Slough,
 Berkshire,
 SL1 3UW
 Tel: 0753 535557

19 High Street,
 Old Town,
 Swindon, Wilts
 Tel: 0793 488448

Prices including VAT

SHOWROOM
 open:
 Mon - Fri
 9.30 - 5.30
 Saturday
 9.30 - 4.30

MAILORDER
 Consumables
 add £2.50
 Hardware
 add £9.00
 (courier)

AMIGA A1200

- 2 Meg RAM
- PSU, Mouse
- Free box of 10 disks
- Mouse Mat

£379 inc VAT

AMIGA A1200

Plus Free Games

- PACKAGE AS ABOVE PLUS
- ZOOL • Striker
 - Pinball Dreams • Trans Write (word processor + spell checker)

£399 inc VAT

AMIGA A600

Amiga A600 + Deluxe Paint III + game

£289 inc VAT

Amiga A600 + 20 Mb HD...

£455 inc VAT

AMIGA A1500

new version

A1500 Accounts Plus pack including Puzznick, Toki, Elf, Operation Systems Software, Home Accounts, Platinum Works, Deluxe Paint III + manual

£545 inc VAT

ADDITIONAL PACKS

- Amiga A500 Plus Cartoon Classics with 10 extra games £359
- A500 Basic Pack (stand alone old version) plus 10 extra games plus Photon Paint plus GFA Basic £999

ACCESSORIES

- 512K Ram + clock £35.00
- 1 Meg Ram + Clock £115.00
- A500 Power Supply Unit £45.00
- Naksha Mouse plus Operation Stealth £29.00
- 1Mb Upgrade for A500 Plus £49.00
- 14" screen filter £17.00

MONITORS

Philips CM4833 MK II Colour Monitor + FREE Lead + FREE game
£210 inc VAT
 with 1 year on-site maintenance

PRINTERS

- Star LC20 Mono £135
 - Star LC200 Colour (9 pin) £188
 - Star LC24-20 (24 pin) £194
 - Star LC24 200 Colour (24 pin) £258
 - Panasonic KXP1124 £222
 - Panasonic KXP 1123 £175
 - Panasonic KXP2123 (24 pin black) £185
 - Panasonic KXP2123 (24 pin colour) £225
 - Citizen 1200 + £110
 - Citizen Swift 24E + Colour Upgrade £290
 - Citizen Swift 9 + Colour Upgrade £195
 - Citizen 240E £299
 - Starjet Bubblejet Printer, SJ48 £299
 - Canon BJ10EX £222
 - HP Deskjet 500 + Leads £327
 - HP Deskjet 500 (colour) £420
 - HP Deskjet 550 (colour) £489
- All above come complete with leads

AMIGA HARD DRIVES / HARD CARD (GVP SERIES II)

- FOR A1500
- 80Mb h/card (0-8Mb) £335
 - 120Mb h/card (0-8Mb) £445
- FOR A500
- 80Mb h/card (0-8Mb) £365
 - 120Mb h/card (0-8Mb) £460
- Upgrade the above with 1Mb SIMM module £39

AMIGA DRIVES

- 1 Meg 3.5" Internal £55
- 1 Meg 3.5" External (RocLite) £67

1000s OF TITLES

THE P.D. WAREHOUSE

1000s OF BARGAINS

£1.35 A DISK

BRITAINS BIGGEST COLLECTION OF P.D. SOFTWARE

100s OF TOP GAMES - ARCADE ROLE PLAYING - ADVENTURE-SPORTS-BRAIN ACHES - SIMULATORS-FAR TOO MANY TO LIST

MOUNTAINS OF MUSIC - SAMPLE EDITORS-POWERFUL MIDI SEQUENCERS-DRUM MACHINES-LOADS OF SAMPLED & MIDI MUSIC DEMOS - COMPOSERS & MORE

GRAPHICS GALORE - LOADS OF PAINT/DRAWING PACKS-ANIMATION-CARTOONS-FONTS-HUGE QUANTITY OF CLIP ART-ETC. ETC.

UNLIMITED EDUCATIONAL - G.C.S.E. REVISION-TYPING & LANGUAGE COURSES-ASTRONOMY-ASTROLOGY-KIDS READING/WRITING/MATHS/SHAPES/COLOURS ETC & LOADS MORE

PILES OF PROGRAMS - UTILITIES-COMMUNICATIONS-DATABASES-ACCOUNTS-PUBLISHING-STOCK CONTROL-COMPILERS-PRINTER DRIVERS-VIRUS KILLERS & LOADS MORE

ALL DISKS
 VIRUS CHECKED

PHONE NOW FOR FREE MASSIVE CATALOGUE!!

081-290-6140

SAME DAY
 DESPATCH

PRINTED INSTRUCTIONS WITH EVERY PROGRAM.

P.D.-SHAREWARE-LICENSEWARE-BUMPER BARGAIN PACKS

NEW TITLES ARRIVING REGULARLY

175A WIDMORE ROAD, BROMLEY, KENT BR1 3AH



We pick out top-quality software and indispensable hardware for you and your Amiga, and we deliver them to you at bargain prices.



**CREDIT CARD
HOTLINE
0458 74011**

Make sure you check out our amazing back issues and subscription offer on Page 180!

10 Great Games Comp

Xenon 2, Pro Tennis Tour, Ferrari Formula One, Nighthunter, Rick Dangerous, Super Ski, Pick 'n' Pile, Carrier Command, Chicago and Satan all in one massive pack! (Doesn't work on A500 Plus or A600).

Description	Price	Order Code
10 Great Games	£24.99	AFGGComp

Two Great Games

A fantastic package with Imageworks' *First Samurai* arcade adventure doubling up with another *Format* Gold-winning game: *Mega-lo-Mania*, the Godlike strategy game from Sensible Software.

Description	Price	Order Code
Two for one	£24.99	AFMegSam

AMIGA FORMAT

Fun School 4

Let the kids and the Amiga make friends, with Europress' acclaimed education software!

Description	Price	Order Code
Teddy Disk	£17.99	AM231
Frog Disk	£17.99	AM232
Spy Disk	£17.99	AM233

Home Accounts 2

Described by *Amiga Format* as 'a package which will suit any household', this is the ideal way to keep track of your financial affairs, from what's in your cheque account to how much is left after the bills!

Description	Price	Order Code
Home Accounts 2	£44.99	AF229

mini Office

Everything you need to turn your own home into an integrated business environment all in one handy package. A word processor, spreadsheet, database, graph utility and disk organiser in a complete set.

Description	Price	Order Code
mini Office	£49.99	AFMinOff

176

FEBRUARY 1993

Amiga Format Mail Order

RAM Expansion

It's well over a year since new Amigas were sold with less than 1Mb of memory. Nowadays many games as well as most serious software, require that magic meg. Here's a bargain way to upgrade your A500.

Description	Price	Order Code
512K RAM Expansion	£25.99	AM237

Amiga Format Binder

Are you tired of all your *Amiga Formats* being left scattered all over the floor? If so, protect them with these stylish and practical black-and-silver binders.

Description	Price	Order Code
One binder	£4.95	AF108
Two binders	£9.00	AF109

New Technosound Turbo

Newly updated sampler from New Dimensions enables you to grab digitised sounds, then sequence them into simple compositions. It contains a new cartridge, updated manual and a set of audio leads.

Description	Price	Order Code
Technosound Turbo	£29.95	AF246



The **AMIGA** Collection

FORMAT

Easy AMOS

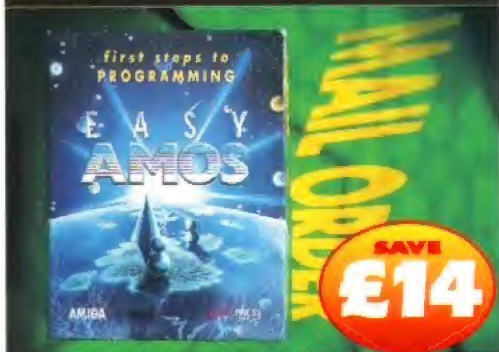

Designed for the beginner who wants to learn programming but doesn't know where to start, *Easy AMOS* is more than a programming language. Based on the successful *AMOS*, it has many helpful examples and detailed explanations to help you learn.

Description	Price	Order Code
Easy AMOS	£29.99	AF247

AMOS Compiler & AMOS 3D

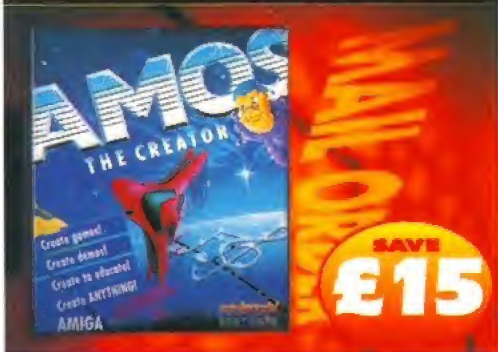

If you want to get the most out of *AMOS*, why not pick up both the most popular *AMOS* extensions in one pack? The *Compiler* translates your *AMOS* creations into stand-alone 100 per cent machine code, while *AMOS 3D* lets you create amazing 3D worlds!

Description	Price	Order Code
AMOS Bundle	£49.95	AF250

AMOS Professional



This is the highest-rated package ever reviewed in *Amiga Format*. Top of the *AMOS* range it updates the famous *AMOS* extended basic programming language with new commands and facilities that make it a real winner! (Needs 1Mb minimum)

Description	Price	Order Code
AMOS Professional	£59.99	AFAMPRO

AMIGA FORMAT

AMOS Manual

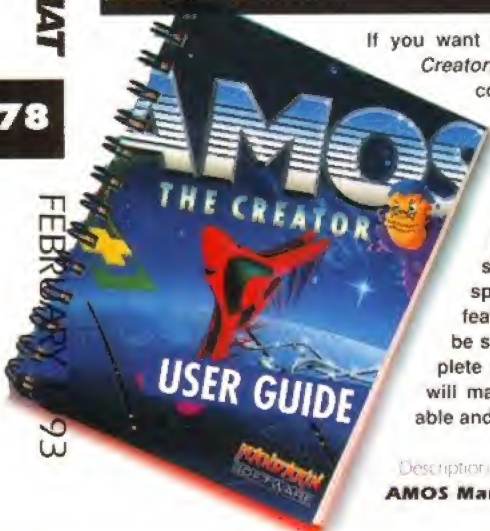

If you want to make the most out of *AMOS The Creator*, this is exactly what you need. It's the complete manual, as supplied with the package, and it also includes an Extras disk that contains all the example programs and extra bits and bobs that we couldn't fit on the Coverdisks this month. We'll continue to give lots of tutorials and advice, and showing you techniques for creating specific kinds of programs, as a regular feature in *Amiga Format*, so you wouldn't be stuck without this book: but as the complete reference work, you'll find The Manual will make your *AMOS* career far more enjoyable and creative!

Description	Price	Order Code
AMOS Manual	£13.95	AF249

Graphics Workshop Manual

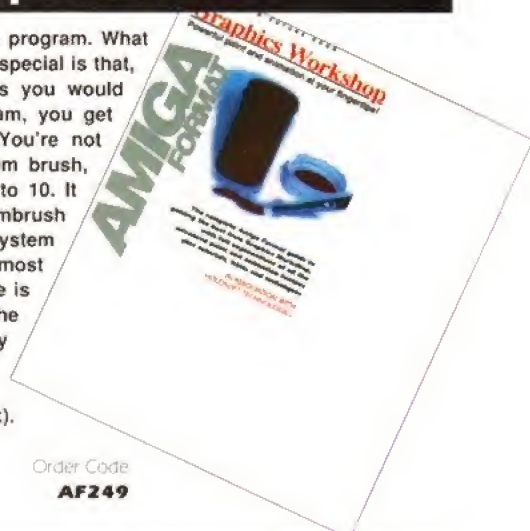

Graphics Workshop is a superb program. What makes this drawing package so special is that, along with all the normal tools you would expect from a top paint program, you get some powerful extra utilities. You're not just limited to using one custom brush, you can pick up and store up to 10. It also features ANIM and Animbrush forms of animation, and a cell system which is quite probably the most powerful animation system there is for the Amiga. Why not get the most out of this top program by buying this expertly illustrated instruction book and tutorial guide (with a special tutorial disk).

Description	Price	Order Code
AMOS Manual	£13.95	AF249

178

FEBRUARY 1993

Amiga Format Mail Order

Name
 Address
 Post Code
 Phone Number
 Description Price Order Code

Total order
 Method of payment (please circle) Access Visa
 Cheque PO

Please make cheques payable to:
Future Publishing Limited

All prices include posting, packing and VAT

Credit Card number
 Expiry Date
 SEND THIS FORM TO:

Amiga Format,
 Future Publishing Limited,
 Somerton, Somerset TA11 6TB

PLEASE DO NOT SEND CASH,
 USE METHOD OF PAYMENTS LISTED ABOVE

For overseas orders call Nikki
 for prices on + 44 458 74011
 AFM/2

WE ARE OPEN ALL HOURS 9am-10pm Mon-Sat
10am-6pm Sun

HARDWARE

A600 + Joystick + mouse mat	£294.00
A500 Plus & Software	£349.00
A1500 & Software	£565.00
1084S Monitor	£199.00
GVP series 2, Hard drive 52 Meg	£350.00
1 Meg sims	£20.00

Phone for 2000 & 3000 prices.

JOYSTICKS

Quickshot II	£6 50
Python Micro Switched	£8 00
Speedking Autofire	£10 50
Competition Pro 5000 Black	£11 90
Maverick Autofire	£12 95
Zipstick Autofire	£12 95
Intruder	£21 50
Aviator Flight Sim	£23 50
Jet Fighter	£12 99

LOOK! LOOK! LOOK!

TRACTOR FEED DISK LABELS
500 plain white labels & software to print
your own professional labels
Only £9.95
SPECIAL OFFER
1000 labels with software £13.50

ACCESSORIES

Amiga Int drive	£49.00
Cumana Ext drive	£54.00
Zydec Ext drive	£49.00
512K upgrade with clock	£23.50
512K upgrade no clock	£17.00
1.5 Meg upgrade with clock	£79.00
1 Meg Amiga plus upgrade	£37.00
8 Meg fast ram, 4 Meg populated	£169.00

DISKS with labels

Unbranded Bulk 100% Certified	
3.5" DSDD	37p each
3.5" Rainbow	44p each
3.5" DSHD	56p each
5.25" DSDD	28p each
Branded Disks	
3.5" DSDD	45p each
3.5" Labels per roll of 1,000	£6 50
3.5" Tractor feed per 1,000	£8 50

Please phone for bulk purchase discounts

MISCELLANEOUS

Mousehouse	£1.60
Mouse Mat	£2.50
Disk Drive Cleaner	£1.80
Amiga Dust Cover	£3.50
Monitor Dust Cover	£3.50
Mouse/Joystick Auto Shift	£14.95
Amiga Light Pen & Software	£32.00
Optical Mouse	£32.00
Squik Mouse	£14.90
Naksha Mouse & Accessories	£22.00
Zy-Fi Amplifier & Speakers	£37.95
Thumb & Finger Trackerball	£19.99
Crystal Trackball	£32.00
Action Replay Mark III	£57.00
Techno Sound Turbo Sampler	£32.00
2 Piece Printer Stand with tray	£5.70
Midi Master	£26.00
Wordworth 1.1	£77.50
Tilt/Tum Monitor Stand	£8.50

PRINTERS

Star LC-20	£128.00
Star LC 24-20	£195.00
Star LC 100 Colour *new	£165.00
Star LC200 Colour	£189.00
Star LC-24-200 Colour	£269.00

STORAGE BOXES

10 capacity	£0 95
NEW 200 Cap box stackable/lockable	£16 50
50 capacity lockable	£3 95
100 capacity lockable	£4 50
80 cap Bank stackable/lockable	£7 99
150 cap Posso stackable/lockable	£15 00
250 cap stackable/lockable	£18 99

Most of the above available in 3.5" and 5.25"

Orders by phone or post to:
DIRECT COMPUTER SUPPLIES
0782 - 311471 Anytime
0782 - 642497 9am - 5.30pm week
0630 - 653193 Evening/Weekend

54 Spring Road,
Longton,
Stoke-on-Trent,
Staffs ST3 2PX

Prices include VAT
Postage please add £3.30
We accept cheques/
P.O.'s/Visa/Access



AMIGA REPAIRS
JUST £44.95 inc.



- ★ Commodore registered
- ★ Over 10 years experience with Commodore computers
- ★ Up to 20 qualified technician engineers at your disposal
- ★ We will undertake to repair your Amiga 500 computer for just £44.95 including parts, labour, VAT and post & packing
- ★ Some computers can be repaired within 24 hours of booking in
- ★ Prices include full service check, overhaul, soak-test and replacement of power supply unit if necessary
- ★ Repairs to keyboard and disk drive also included (£25 extra if these units are unrepairable and require complete replacements)
- ★ All repairs covered by a 90 day warranty



Upgrade your Amiga from 512K to 1Mb of memory for just £13.00
SPECIAL EXCLUSIVE OFFER:
If you submit your computer to ourselves for repair, enclosing this advert along with just an additional £13, we will supply and fit a 512K memory expansion at no extra cost.

How to take advantage of this exceptional offer: simply send or hand deliver your machine to the workshop address detailed right, enclosing payment and this advert, and we will do the rest. (Important, please include a daytime telephone number and fault description).

* If you require 24 hour courier to your door, please add £5 else your computer will be sent back by contract parcel post.

WTS ELECTRONICS LTD
STUDIO MASTER HOUSE
CHAUL END LANE
LUTON, BEDS, LU4 8EZ
Telephone (0582) 491949 - (6 lines)
WTS reserve the right to refuse machines that in their opinion are beyond reasonable repair - normal charge applies.

Back Issues

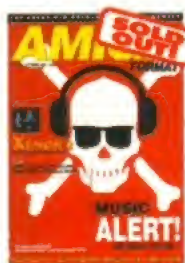

ISSUE 3
Majoring on music with a big release.



ISSUE 4
The complete story of the Amiga.



ISSUE 5
Explore the amazing world of 3D.



ISSUE 6
Simulation games: why are they such an obsession?



ISSUE 7
Learn to program with Dave Jones!



ISSUE 8
How to make great videos with your Amiga's help.



ISSUE 9
Multimedia: what is it, and what can it do for you?



ISSUE 10
Business software explained and the best game ever!



ISSUE 11
Chaos! The buzzword of the year, on the Amiga.



ISSUE 12
How to get into music, with a free covertape tune!



ISSUE 13
Games made from films: why are they always so poor?



ISSUE 14
Public Domain special: we pick out the best free software.

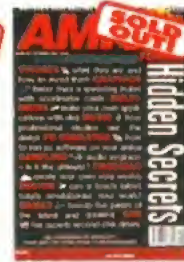

ISSUE 15
A real mixed bag, a trip around the world of the Amiga.



ISSUE 16
CDTV: the very first look at the future of home computers.



ISSUE 17
The first look at true colour, bringing 16 million colours!



ISSUE 18
Massive Christmas 1990 special with complete game!



ISSUE 19
Beginners' special, explains how to care for your Amiga.



ISSUE 20
The best there is in Amiga software chosen & explained.



ISSUE 21
Paint programs: every single one tested and rated.

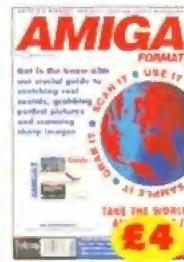

ISSUE 22
Samplers, scanners and digitisers can change your world.



ISSUE 23
3D secrets revealed, complete full-price game on disk.

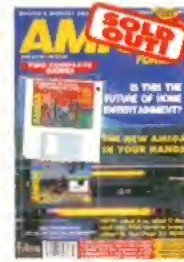

ISSUE 24
CDTV exclusive, plus two complete full-price games!!



ISSUE 25
DTP explained plus the massive round-up of the year.



ISSUE 26
Deluxe Paint IV - exclusive disk demo and first review!



ISSUE 27
True Colour brings 16 million colours to your screen.



ISSUE 28
The secrets of game graphics revealed by Vivid Image.



ISSUE 29
First review of the A500 Plus, word processors tested.

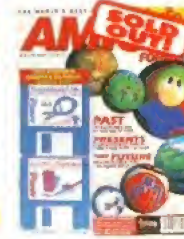

ISSUE 30
Huge XMAS special with two complete full-price programs!



ISSUE 31
Beginners' special plus how to make your own games.



ISSUE 32
Every single CDTV disc available is under review.



ISSUE 33
Landscape program Vista, plus how to create cartoons.

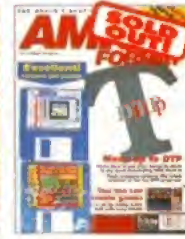

ISSUE 34
Desk top publishing: explained. Full Page Setter DTP program



ISSUE 35
What to do if you have the art or music program, but not the talent. Plus HAM point program Spectrator Jr.



ISSUE 36
With the multimedia program CanDo! Jr and the full low-down on the A600 and the CD-ROM drive!!



ISSUE 37
The amazing story of musicians and artists who have made it big with an Amiga, plus Animation Station.



ISSUE 38
Got an A500? Learn how your machine can become a Super Amiga! Plus: choose a monitor from our guide and IntroCAD.



ISSUE 39
Bored with games? Think you can do better? Read the first part of the Bullfrog's guide. Plus: DevPac 2.



ISSUE 40
We give you all the hints and tips on how to get the most out of Deluxe Paint. Plus: TVText and CrossDOS.



ISSUE 41
The inside story on two new Amigas: the A4000 and A1200. Plus: complete word processor Scribble!



ISSUE 42
The top 30 games of all time tipped. Plus: Complete AMOS language and Lemmings 2 Demo on the disk.

Subscriptions

Think carefully... then do it.

Consider. A year's worth of the most popular Amiga magazine in the world, delivered in a mysterious silver plastic wrapping straight to your door every month. What's in it for you?

Well, it's a luxury, isn't it? Of course, you could go out and buy the magazine every month. But isn't it nice to treat yourself occasionally?

Save the time and trouble involved in that monthly excursion to hunt through the shelves at the newsagent

– instead, put your feet up and enjoy the feeling as your monthly treat is delivered to your door.

And remember that in those moments of crisis – when others are chasing round all the shops in town in a desperate search for the last copy of a sell-out issue – you'll be laughing.

So how much does it cost to enjoy the luxury of having someone else do all the hard work? Surely it must be a tidy bob or two?

Absolutely nothing. Not a penny. Postage included, the whole thing works out slightly cheaper than 12 issues of the magazine at normal price.

When you consider that means over 2,500 pages of magazine with reviews of 300 new games and over 150 items of serious software and hardware, plus stacks of information about how to get the best out of your machine, and all the latest news of what's going on in the Amiga world – you begin to realise it's a heck of a deal.

So how can you be so unkind to yourself as to let the opportunity go?

UK £38.95

Europe £67.95

Rest of world £97.45

We will also give you the choice of any one of these great freebies...



Harlequin

Here you get 23 levels of crazy platform mayhem in search of a vital organ. It got a massive 78 per cent in **Amiga Format** Issue 33.



Wizkid

A stunningly bizarre platform puzzle adventure game from the inappropriately named Sensible Software. Scored 93 per cent in Issue 37.

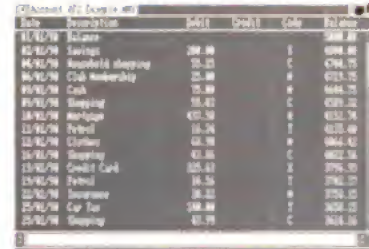

Personal Finance Manager

Microdeal's DIY domestic-budgeting system is ideal for balancing your cheque-book, or keeping small business accounts!



Two Free Issues

Alternatively, you can have the best free gift of them all – two extra issues of Amiga Format. Extra information and entertainment.

Amiga Format **subscription** order form

Yes! please enter/renew my subscription to Amiga Format and send me the software of my choice

Tick as appropriate Harlequin Wizkid Pers. Fin. Manager Free Issues
 UK £38.95 Europe £67.95 Rest of World £97.45

Please send me the following Amiga Format back issues _____

Name _____

Address _____

Post code _____

Telephone No. _____

Method of payment Access Visa Access Postal order

Total Order _____

Credit card No. _____ Expiry Date _____

SEND THIS FORM TO:
Amiga Format Subscriptions
Future Publishing Ltd
Somerton, Somerset
TA11 6TB

Please make cheques payable to
Future Publishing Ltd
This offer is valid until 31 Mar 1993

Never mind the Ballistics

here's

AMIGA SHOPPER

For serious Amiga use

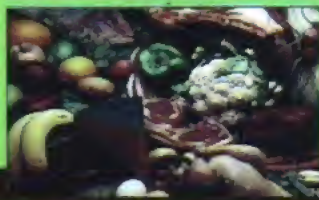
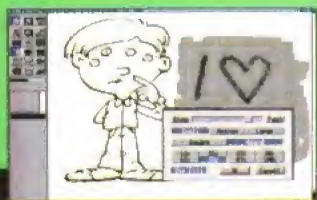

Make the right buy with our in-depth round-up of 20 printers. New to the Amiga? Then read our special beginners' guide, and check out 15 pages of Amiga Answers devoted to solving your Amiga problems

PLUS: VIDEO, PROGRAMMING, DTP, AMIGADOS AND MUSIC

All the advice you'll need...

EXPERT ADVICE AND TIPS FOR EVERY AMIGA ENTHUSIAST

AMIGA

From the makers of **AMIGA** FORMAT

ISSUE 22 • FEBRUARY 1993 • £1.50
YOUR **DEFINITIVE** AMIGA GUIDE

SHOPPER

Which printer?

INSIDE

- **GRAB THOSE IMAGES!**
The ColourPlus and Hi-Amiga 12 digitisers are reviewed and rated
Videos: page 27
- **LANGUAGE OF THE PROS**
Learn how to program the professional way - it's easier than you think
C Programming: page 124
- **ANNIHILATE ANGST**
Fourteen pages devoted to solving all of your Amiga problems
Amiga Answers: page 31
- **SOFTWARE FOR FREE**
A look at the very latest low-cost and no-cost Amiga software
Public Domain: page 139

Make the right choice with our round-up of 20 dot matrix, inkjet and laser printers

PLUS The complete beginners' guide to the Amiga. If you've just bought a new Amiga, then you need to read this. Make a start on page 24!

future PUBLISHING
Your guarantee of value

WIN! A FAX MODEM



Just the facts, ma'am

**ONLY
£1.50**

**COMMODORE
1084S STEREO
MONITOR**
Including FREE Lead
ONLY £199.00

**PHILIPS 8833 MK II
STEREO MONITOR**
Including FREE Lead
ONLY £299.00

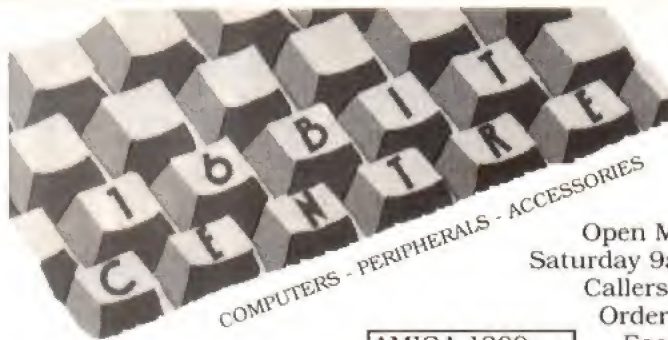

COMPUTERS - PERIPHERALS - ACCESSORIES

**KCS POWERBOARD
PC EMULATOR
FOR AMIGA A500**
ONLY £159.00

**GOLDSTAR
MULTIMODE HIRES
MONITOR WILL
ACCEPT AMIGA AND
VGA INPUTS £249.00**

Open Monday to
Saturday 9am - 6pm
Callers and Mail
Order Welcome
Easy Parking

**AMIGA 1200
NOW IN STOCK
£369.00**

HARD DRIVES

**GVP SERIES II
1500/2000**
80Mb Quantum
Space for 8Mb RAM
£319.00

**GVP SERIES II
1500/2000**
120Mb Maxtor
Space for 8Mb RAM
£379.00

**GVP SERIES II
1500/2000**
120Mb Quantum
Space for 8Mb RAM
£405.00

**GVP SERIES II
A500**
80Mb Quantum
Space for 8Mb RAM
£369.00

**GVP SERIES II
A500**
120Mb Maxtor
Space for 8Mb RAM
£405.00

**GVP SERIES II
A500**
120Mb Quantum
Space for 8Mb RAM
£425.00

AMIGA A600 FUN PACK

Amiga A600, Mouse, Modulator, Manuals, Workbench, Joystick, Disk Box, 10
Disks, Dust Cover, Dpaint 3, 1Mb RAM, PLUS 13 GAMES, Lemmings, Simpsons,
Captain Planet, Safari Guns, Bubble Ghost, Tin Tin, Purple Saturn Day, Jumping
Jackson, Hostages, Bobo, Krypton Egg, Shuffle Puck Cafe

ONLY £329.00 inc VAT

COMMODORE
386 x 20
Bridgeboard
£399.00

Amiga A600
Amiga A600 Wild, Weird, Wicked Pack ...£335
Amiga A600 Cartoon Classic Pack£299
Amiga A600 Epic Pack£479
Amiga A600 Standard Pack£279

SOFTWARE

FINAL COPY 2	£64.99	AMOS PROFESSIONAL	£45.00
AMOS + EXTRAS DISK	£32.00	QUARTERBACK V5	£39.00
BROADCAST TITLER II	£139.00	PRO-WRITE V3.2	£69.00
HOT LINKS	£49.00	IMAGEMASTER	£32.00
DIGIVIEW MEDIA STATION	£79.00	PHOTON PAINT 2	£25.00
LATTICE C V6	£199.00	FINAL COPY 1	£45.00
PAGESSETTER V2	£42.00	DESIGN WORKS	£59.00
PAGESTREAM V2.2	£125.00	DOS 2 DOS	£28.00
PAGESTREAM FONTS PACK	£49.00	O/BACK TOOLS	£42.00
X CAD 3000	£239.00	WORDWORTH 2	£72.00
CROSS DOS V5	£39.00	SUPERJAM	£69.00
SCENERY ANIMATOR	£53.00	REAL 3D BEGINNERS	£99.00
TURBO PRINT PROFESSIONAL	£38.00		
PEN PAL, Excellent easy to use word processor	£53.00		
IMAGEMASTER 24 Bit Image Processing, includes effects	£105.00		
ART DEPARTMENT PROFESSIONAL	£119.00		
DIRECTORY OPUS	£29.95		
KIND WORDS 3	£39.00		
BARNS + PIPES PROFESSIONAL	£179.00		
MORPH PLUS	£149.00		
THE WORKS PLATINUM, Integrated package	£39.00		
IBM EMULATOR emulates a PC on the Amiga	£39.00		
VISIONARY Adventure creation language	£53.00		
MINI OFFICE Integrated package	£39.00		
REAL 3D TURBO/PROFESSIONAL	£269.00		
PROFESSIONAL PAGE V2.1 with tutorial video	£115.00		
PROFESSIONAL PAGE V3.0 New Version	£129.00		

HARDWARE

COMMODORE 386 Bridgeboard For 1500/2000	£399.00
ROM V2.04 AND ECS DENISE	each £29.00
A570 CD ROM for A500	£289.00
MEGACHIP 1500/2000/500. Gives 2 Mb of chip memory	£139.00
WIRELESS MICROPHONE Ideal for sampling	£75.00
GVP PC EMULATOR (for GVP A500 hard drives) 16Mhz	£195.00
A530 40 MHz Accelerator with 52 Mb hard drive with 1 Mb ram	£639.00
A530 40 MHz Accelerator with 120 Mb hard drive with 1 Mb ram	£749.00
DCTV 24 Bit Graphics Board	£399.00
GOLDEN GATE 386/25 Bridgeboard for 1500/2000/3000	£425.00
TV TUNER for Philips and Commodore monitors	£69.00

PRINTERS

STAR LC24/100 Mono...24 pin inc free lead	£195.00
STAR LC100 9 pin colour inc. free lead	£175.00
STAR LC20 9 pin mono inc. free lead	£132.00
CITIZEN PROJECT Inkjet mono printer inc. free lead	£359.00
HP DESKJET 550 COLOUR inkjet inc free lead	£569.00
CITIZEN SWIFT 9 COLOUR 9 pin colour printer inc free lead	£175.00
CANON BJ10 EX bubble jet printer inc free lead	£219.00
STARJET SJ48 bubble jet printer inc free lead	£225.00
HP DESKJET 500 inkjet inc free lead	£349.00
HP DESKJET 500 COLOUR inkjet inc free lead	£479.00
CITIZEN 200 COLOUR 24 pin printer inc free lead	£239.00
CITIZEN 240E COLOUR, 24 pin printer inc. free lead	£275.00

MEMORY

SUPRA RX500 8Mb RAM BOARD FOR A500/A500+			
With 1Mb	£92.00	With 2Mb	£117.00
With 4Mb	£185.00	With 8Mb	£285.00
A500 512K With Clock	£29.00		
A500+ 1Mb	£32.00	A600 1Mb	£47.00
ROM 1.3/2.0 Sharer With Switch (Rom 1.3 £22.00)	£12.00		
ROM 1.3/V 2.0 Sharer by Keyboard reset (Rom 1.3 £22.00)	£22.00		

MODEMS & FAX

Supra 14400 Fax Modem v32 bis inc. comms software	£255.00
Tornado 9600 Fax/Modem (Speeds up to 38000)	£399.00
Supra 9600 v32 Fax/Modem inc. comms software	£189.00
Supra 2400 Plus, MNP5 & V42 Bis (speeds up to 9600)	£129.00
Supra FAX MODEM SOFTWARE	£29.00
Supra 2400 Plus Internal Modem for A1500/B2000	£99.00
Tornado 14400 Fax Modem (Speeds up to 57000) NEW IN	£499.00

AMIGA A1500

The A1500 inc. Philips or CBM 1084s or 5 monitor. Twin drives, Dpaint 3.
The Works Platinum, Home Accounts, 3 Games + Joystick
ONLY £739.00

AMIGA A500 part exchange available - please phone

ACCELERATORS

Microbotics Accelerator VXL-30, 25MHZ	£222.00
Microbotics Accelerator VXL-30, 40MHZ	£351.00
Speed Merchant Doubles Amiga Speed	£129.00
GVP 68030 25MHZ WITH 1 Mb RAM	£545.00
GVP 68030 40MHZ WITH 4 Mb RAM	£779.00
GVP 68030 50MHZ WITH 4 Mb RAM	£1090.00

HOW TO ORDER:
Either call our number
below with your credit
card details, or send
cheque/PO or credit
card details to our
address. Cheques made
payable to
THE 16 BIT CENTRE
Prices subject to change without
notification.

All prices include VAT and Courier Service

16 BIT CENTRE

Units 15-17,

Lancashire Fittings Science Village

Claro Road, Harrogate HG1 4AF

**EXTENDED WARRANTY
AND MAINTENANCE
CONTRACTS AVAILABLE
ON ALL ITEMS. PLEASE
CALL FOR FURTHER
DETAILS**



Tel (0423) 531822/526322

JUST BOUGHT AN AMIGA?

FROM: THRASH, CLEVELAND

I have an A600 with a Zappo 1Mb memory upgrade and a Cumana external floppy disk drive. When I load up Workbench, it tells me that I have 1,855,328 Mb of graphics memory. By the time Workbench has finished loading, this figure drops to 1,731,728 Mb of free memory. When I click on the Workbench icon, it drops again to 1,715,504. I'm confused – just how much memory does the extra disk drive take?

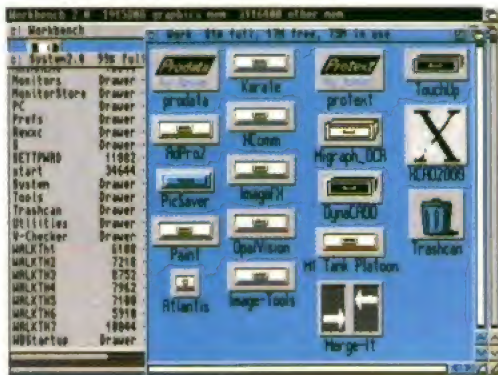

Every time you do anything with Workbench, the memory meter at the top of the screen changes.

About 25-30K. Workbench 2 also takes a large slice out of RAM for its own purposes – try removing the expansion and then loading Workbench, and comparing the difference in memory. As for the amount of free memory going down when a directory window opens; the Amiga has to remember what was underneath the window, so it can be replaced when the window closes. This takes even more memory away, but leads to a small tip which can help conserve memory – always close redundant windows if you are running low on memory.

2) When I use a hunter/killer virus checker, it often tells me that the disk it is checking has a non-standard bootblock (especially my PD collection). Then, when I try doing a check for file viruses, I get the message “Not a DOS disk in device DFx” – that is, it doesn't matter which drive I put the disk in. That's the error message for *BootX*, for *Virus Checker 6.15* it's more like ‘Error locking file Not a valid DOS disk’. What's going on?

Starting at the top – although bootblocks are always the same size, they differ greatly in their content. Many programmers like to design their own disk formats, which either load quicker or can store more than the standard AmigaDOS format. In order for such systems to work, the bootblock has to tell the Amiga where the next bit to load is, as well as displaying messages, putting up graphics and playing sound samples.

Non-standard bootblocks like these are common in two software categories: commercial arcade games and Public Domain demos. Such disks are not arranged like standard disks that you can look at with Workbench – that's the reason you get “Not a DOS disk”, because it isn't! Such disks are immune to most file viruses (which can't make head nor tail of them) but are still susceptible to bootblock viruses.

You often get a message like “Error on block 880 – key set twice” when examining such disks through Workbench. The reason for this is that the first thing Workbench tries to do when you pop a disk in is have a look at a position halfway on the disk (the start of track

Workbench

This being written in the season of good cheer, **Pat McDonald** is where he should be – down the pub. Here are some conversations he overheard, all being Amiga-related problems and solutions.

40, or block 880) and check to see if the disk is a standard Amiga type.

Now, these non-standard disks will, in 99 per cent of cases, fail to work with Workbench because standard Amiga disks have a lot of integrity codes written on them, and non-standard disks do not. What that means is that, if part of a disk goes bad (the little bits of magnetism get scrambled) then Workbench can attempt to detect where on the disk the problem happened, and how bad it is.

As for the different error messages, the way any program displays an error is up to the programmer. The two different messages are referring to the same problem, that is they can't look at any standard files on such disks, because the disks have been custom designed by somebody. Incidentally, game disks are usually not custom encoded for bigger screens or longer sounds – they're like that so it's more difficult to pirate them.

3) When checking the tracks of some disks I get the message “... has a checksum error on disk block 1693”. Frequently I also get the message “DOS Error 9955”. A particularly bad case was a disk I ordered from *Diskcovery PD* called *Microdeal Music Disk*. When I boot the disk, it works as far as the intro screen, but then hangs. Is it possible to repair this error?

It's almost certainly not a natural error. There are two explanations – either the disk has been damaged by a virus (unlikely as the errors are occurring in the same place – most viruses are more randomly destructive).

Or it's a protection track, left unformatted so you can't copy the disk through Workbench. I regret piracy has removed a large part of the trust from the programmer/customer relationship.

4) When using *Virus Checker 6.15*, (which I have dragged into the *WBStartup* drawer on my Workbench disk) I cannot get the program to learn new bootblocks. I just get a message saying “Error sorry can't update brainfile”. When I checked the *Cry for Dawn PD* disk (pictured below) I received the message, “Bootgirl data is protected from being read you will have to use ‘Protect filename +r’ if you want this file to be checked for viruses”. I tried it, I just got “Unknown Command” messages.



Many PD programmers use non-standard disk systems, to squeeze even more graphics and sound on to their disks.

Continued overleaf

NICE ONE NORMAN

FROM: IAN BOOKER, HARROGATE

I am going to upgrade to an A1200, preferably with a maths coprocessor and a hard drive, so...

1) What can I reasonably expect to see in the way of expansions for it in a couple of months?

IDE hard drives, which will be getting more expensive because of the pound-to-dollar exchange rates: PCMCIA memory cards, which will stay about the same price (the price is going up because of the economic crisis, but coming down slowly as production gears up). PCMCIA hard drives will probably be available, but expensive. Several trap-door memory expansions should be on sale, and maybe an '030 card or two as well (these will take longer to get into production).

2) I am planning to run *XCAD* and *Imagine* on the new machine. I currently have a Philips CM8833 Mk 1 monitor, but what can I gain by getting an SVGA or multisync instead?

OK, remember, you asked about *XCAD*. If you want to edit at high resolution, the screen will flicker – some people can work with interlace, some can't. If you plug a multisync or SVGA (SVGA's are cheaper, but do test them first – some don't work on the Amiga) and set



XCAD 2000 is a design program, but a TV isn't suitable for using it – the higher resolution you use the better.

your Amiga Productivity mode on, then you can edit interface screens in comfort on a rock steady display.

If you know someone who has *Art Dept Pro 2* you could render your designs into 24-bit true colour IFF files, which could be converted to HAM8 ‘more colours than you can shake a stick at’ mode or 256-colour mode with *Art Dept Pro 2*. You could view such pictures with *Multiview*. SuperHires images (1,280 width but not interlaced) could be done, though they don't display well on a standard A1200 in HAM8 mode (256 colour is fine). They worked fine on an A4000 though!



MINE'S A LARGE ONE

FROM: GEOFFREY STUTAFORD, EPSOM
I decided to change my ageing A500 for an A1200. At the moment I have a CM8833 monitor, Star LC10 printer and a Cumana second drive attached to my new A1200.

My problems started when I attached a Rocgen Plus genlock to the machine. If I have my other equipment plugged in as well, then the machine will not even start up, simply displaying a software failure message. If I disconnect everything except the genlock, then I can get to the animated disk that appears when you turn the machine on, but cannot get any software to boot. Why does the machine go belly up as soon as I put a disk in the drive?

Genlocks perform a clever trick – they let you overlay Amiga graphics on to a video signal, which you can then record. However, in order for the precision synchronisation needed to happen, the Amiga has to be in

a certain state of low usage. In addition to that, genlocks do horrible things to your Amiga power supply, like drain it dry.

With a cut-down machine, it all goes well until the drive spins, needing time on the buses (address and data) and taking quite a bit of power as it gets up to speed. Bang, your Amiga then falls over in horrific genlock accident.

I noticed that the power supply unit is marked A600 and is quite light in comparison to a friend's A500 power supply. Does the weight of a unit make any difference to the power supply capability? If I fitted a bigger power supply in the A1200, would that solve the problem? Or should I get a 12 Volt DC power supply for the Rocgen Plus?

I tried plugging a Rocgen Plus into an A2000 with a hard disk and memory, not too over the top considering the size of the power supply, yet that hulk couldn't power the genlock. Methinks the Rocgen is a bit greedy even for a genlock.



The Rocgen Plus is notorious for producing overbright displays and for hogging your power supply. Take note!

However, no trouble at all after I borrowed a power supply from a Sega GameGear recharger. Who said Segas were useless? Any 12V DC adaptor with the right connector will help – get a big meaty one.

Because you've got Workbench 2, this is a lot easier to sort out. In a nutshell, the programs can't find the files they need to run. If programs on Workbench standard disks work fine from floppy but do not work when you've dragged the icon to your hard disk, you will have to drag more files from the floppy into the relevant drawer on your hard disk. (Files in the floppy libs directory have to go to libs on the hard drive, devs to devs, and so on).

However, files on a disk without a relevant icon file (the same name with .info after it) do not show up on Workbench. The next thing about Workbench 2 is if you double-click on a disk icon, then select Show/All Files from the Window menu, every file is given an icon. So you can drag these invisible files on to your hard disk. Remember, you will have to do the same Show/All Files selection for your hard disk too.

Hard disk users with Workbench 1.3 – you have to use the Shell or upgrade.

5) As I said earlier, I've dragged the *Virus Checker* icon in the WBStartup and it runs automatically. Why doesn't this work with programs like *WizardClock* or *CrossDOS*?

Either because the program was written to be incompatible with the WBStartup drawer (rare but not unheard of) or again, some files are not available from the hard disk. When AmigaDOS boots up from a disk (hard or floppy), it expects all the fonts, libraries, device drivers (including printer drivers) and Preferences settings to be on the disk it booted from.

6) I'd just like to congratulate 17-Bit Software on their incredibly speedy PD mail-order service. See, it's not all whinging!

Good. But they're not the only ones.

BOOK A GIG?

FROM: RUDESH AMBASNA, MITCHAM
I currently own an A2000 and I use it mainly for constructing music. I use *MED* for the actual music arranging, and *Audio Engineer* for sampling. I have 3Mb of RAM.

1) I tend to use long samples rather than short instruments. Apart from *OctaMED*, is there a better music construction program better than *MED* for this sort of work?

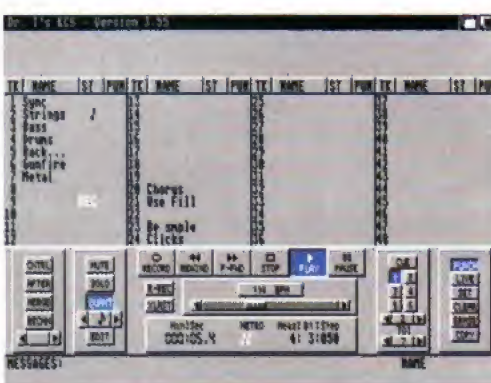

Dr T's KCS is currently the best MIDI sequencing package available – maybe *Music-X 2* is better, maybe not.

Yes, Dr T's *KCS Level 3.5* is the acknowledged, best music package available on the Amiga (I understand *Music-X 2* is currently being worked on for release later in 1993). The original *Music-X* is best steered clear of if you haven't got a MIDI interface and at least one MIDI instrument. *KCS Level II* needs extra hardware too to be really good.

2) *MED* will not play a sample longer than about 131K. Is there a way around this?

No. At least, I've not heard of one. Apart from reducing your sample rates, to have longer samples (danger, quality loss, I hear you shriek) in the same space.

3) I can only load about 880K of samples into *MED* before it displays an "Out of Memory" message. If I then save the data as a module, the total length of the module is less than 1Mb (again, about 880K). Furthermore, I can copy this module to the RAM disk three times. Why can't I use all 3Mb of memory to load in samples?

This is because you have only got 1Mb of chip RAM for storing samples. Bearing in mind that some chip RAM is usually needed by the program (this is for things like the graphics, disk drives etc) then you are running out of chip RAM. You could try fitting a 2Mb chip RAM expansion into your A2000 – the only one that I've actually seen working (*Wings* doesn't work on it) is the DKB MegaChip 2000, which is available from 16 Bit Centre (0423 531822) as well as many other suppliers.

4) And finally can you give me some basic information about MIDI?

It's a way of wiring a plug, and then a fairly simple system for sending and receiving information. There are three common types of socket, namely MIDI In (for listening), Out (for talking) and MIDI Thru (directly repeating what's coming in without change). They are usually found on the backs of musical instruments and equipment (like professional-quality samplers). The Amiga has none of these as standard (except the CDTV – no MIDI Thru) but a £25 interface plugged into your serial port gives all three.

You can then run MIDI software on the Amiga, to control and sequence MIDI instruments and equipment. Oh yeah. MIDI stands for Musical Instruments Digital Interface. Or was it Idiots? Anyway, have a look at the advert for *Future Music* – that's where old Maff Evans went to.

ERE, YOU KNOW YOU SOLD ME...

FROM: LGP FARMER, NORTH HUMBERLAND
Two weeks ago I purchased an A1200 which works very well on its own. However, there is a problem. It does not like either of my external drives. These are both PC880s and both are fine on the A500.

The trouble seems to arise when reading from the disk in the external drive. Quite randomly it will start claiming that there is a "Read error on block ???", but it's never the same block each time. If I click on 'Cancel' then the machine carries on as normal. It doesn't happen that often but when it does it is very annoying.

Occasionally, the machine reports a disk as NDOS (not DOS) and refuses to load data from it. If I take out the disk and put it in again then the disk works fine!

I reported this problem to Wang, who dutifully brought around another A1200, with exactly the same results. It would seem that there are some problems between the A1200 and Power Computing's PC880. Has anyone else had the same problem? Is it curable? There are no problems at all when I use the internal drive.

I haven't heard of anyone having the same problem, and as the Power PC880B was returned several months ago I have no means to test it myself. However, the fact that both your drives don't work gives credence to



The Power PC880B, apparently not compatible with the A1200. A shame, because it's good on other machines.

the impression that it doesn't work. It's probably a similar problem to the RocLite drive from Roctec not working with Workbench 2, that is it probably goes a bit too fast.

THERE'S THIS ESSEX MAN...

FROM: JOHN ROMBAUT, ESSEX

The problem that I seem to be having is when I get a screen indicator such as "Error while opening 203" or "Error 880". It's totally useless to me when presented as such because it gives no real indication as to what precisely is the fault.

As there does not seem to be any available publication explaining the numbers I have gradually been compiling my own index, but nowhere can I find explanations for error numbers 34, 66, 103, 106-119, 123-201, 215, 217 and 880. I also wonder whether there are any numbers used between 217 and 880. Can you help at all?

Sorry, no evil intent, it's just a writer's trick to tie all the loose ends up. I apologise. Errors on disk block 880 are explained above in 'Just Bought an Amiga?'. I assume that the others are happening when you are using the Shell or CLI - if they are happening to you on Workbench, then only Shell can give you a clue as to what is going on. I don't know what version of Workbench you are using, so if you haven't got 1.3 or later, my advice to you is to UPGRADE.

I'll assume, like I said, that you are a new Shell user. There is a handy feature to get a little explanation up, which can at least give you a bit of a clue as to precisely what you are doing wrong. I get errors like these every day. When you have got an error just type this and hit Return:

Why?

Easy when you know how. Now, I can't tell you what all the errors mean, but here are the common ones. 103

is simply your computer is running out of memory. It happens on small Amigas, and it happens on big Amigas. You are always limited if you're trying to use more memory than you have got.

121 is also very common. It's when you try to use a data file as a program - like just typing the name of a picture you have saved with *Deluxe Paint*, for example. In this example, you would have to type the name of a picture displaying program, like *Vilbm, Showpic* - get a couple of PD slideshows and they will usually have the program on them (hopefully with the documentation file, often just called *Readme* for obvious reasons). Remember, programs are executable by the computer, data files are not executable - the computer cannot understand data files.

205 means you were just plain wrong - you tried to access a file that doesn't exist. Typing error - we're all human. The easiest way to avoid problems with the Shell is to always give the full path to where you want to be (name of a disk, colon, directories/subdirectories/nameoffile. Like this:

MyDisk:MyDir/MyLowerDir/MyProgram

Upper or lower case (capitals or little letters) very rarely make a difference with Shell. Learn from your mistakes and keep trying.

SPILT TRASHCAN



I was minding my own business when this trashcan icon gets spilt all over my screen. Disgraceful!

Without success. How do I do it?

FROM:

IAN TROTMAN,
SOUTH WIRRAL

I am new to the Amiga, having just bought an A600HD. While I was copying files on the hard disk, I somehow managed to create the icon 'Copy of Trashcan'. I have tried everything short of reformatting the hard disk to erase this

Assuming that the errant file is on your boot partition of the hard disk, then type this into a Shell. Notice the double quotation marks, which you have to use if the name of a file contains a space:

Delete "Sys:Copy Of Trashcan"

If the file is in a lower directory (Sys is just Amiga shorthand for the disk the Amiga has booted from - usually Workbench) then put the name of the directory followed by a slash. If the file is an icon file (followed by .info) then don't forget to add that:

Delete "Sys:MyDir/Copy Of Trashcan.info"

Oh yes. The file is probably protected from deletion, which is why you couldn't get rid of it. Type this:

Protect "Sys:MyDir/Copy Of Trashcan.info" rwd

Only the d is necessary, the other bits are for readable, writeable and editable.

I WANT TO SEE MORE

FROM: MARTIN SMEE, CROYDON

I have a standard 1Mb A500 revision 5 with good old Kickstart 1.2 in it. I have owned the machine for six years now and have not yet found a piece of software that doesn't work with it. It's been great and has never failed, but now I feel a hankering to catch up a bit with the latest machines.

1) I want Kickstart 1.3 and 2.04, together with the 8372A Agnus to give me 1Mb of chip memory, but I'm not sure whether I can go that far or not. Is it possible and if so how?

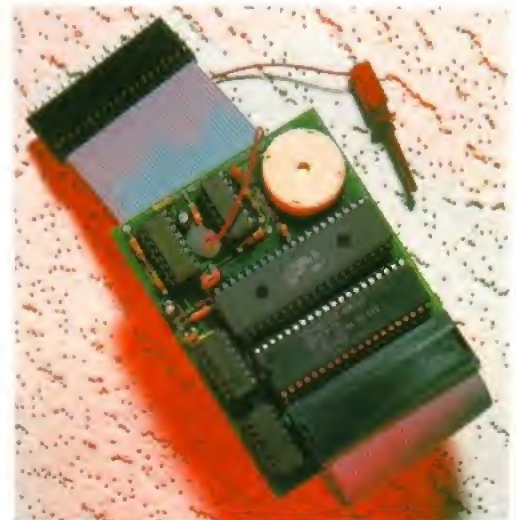

ROM sharers were popular in the USA years before they caught on over here. Want a different Kickstart? Get one!

It is possible, as the revision 5 board can take the bigger Agnus and Kickstart chips. However, it is not easy for the inexperienced, and it is printed every so often in *Amiga Format* (Issues 18 and 32). I regret you can't buy one, they are all sold out. Time for a repeat performance? With A2000 bits in too? And a smashing great orangey bit in the middle? I would but this is a pretty

Continued overleaf

I DRIVE A FERRARI

FROM: PAUL ANDREWS, SITTINGBOURNE
If I was to purchase a hard drive for my 1Mb A500, add about 4Mb of RAM to it and install *Formula One Grand Prix* on it, would the actual game play improve? Would the graphics be smoother? Would an accelerator be a better idea? Or is it impossible to improve the speed of a game after the programmers have finished with it?

Hard disks just load and save faster, so when a game is loading and saving you spend less time not playing. An accelerator (Amiga with a faster processor, plus suitable faster RAM than found in your average A500, A500+, A600, A1500 or A2000) will indeed make

certain games, notably simulations and including *F1GP*, update the screen faster, so giving a smoother moving view. However, not all games are faster, as they already go fast enough, so to speak.

Arcade games are usually clocked to a certain speed. Also, a lot of old arcade games (not all) use programming methods which make accelerators wave their little silicon legs in the air. Programmers are much more accelerator-aware than they have been - even so, there are still problems. It's not just a question of going to a bookshop and getting reference material off the shelf - 99% of bookshops will not stock up to date knowledge. Anyone with any recommendations, please drop me a line, because a lot of people want to know about the 68020 and other big processors.



Want to make your machine move like a Ferrari? Watch out - not all software will speed up...

small issue and the articles do need a lot of updating, we don't want people getting it wrong and ending up killing their Amigas, now do we?

2) I was going to trade in my A500 for a CDTV, but the offer ended too soon. Are similar offers available? Do people regularly offer trade-in deals?

Simple, you go to a shopkeeper and make him an offer. Or wait for him to make you an offer. I really am the wrong person to talk to. Get out there and hustle!

3) I'm stuck as to what to choose, an A570 CD-ROM drive or a GVP hard drive. I think CD-ROM is a great idea, but I have a gut feeling that it will be better yet with the MPEG chip set. Can you clarify matters a bit? Is CD-ROM here to stay?



The A570 was the first Amiga CD-ROM interface (as opposed to a full CDTV). I doubt it will be the last either.

CD-ROM is here to stay, but exactly what direction it takes is anyone's guess. Commodore committed themselves to the MPEG standard – when the bits appeared for the rival CDI system – then they had to make 'an announcement'. Any actual new CD designs are vapourware – stuff which you can't buy yet and you shouldn't really until you've read a review or two.

4) I believe this one is unsolvable, but have a go anyway Pat. I own a very old Tandy DMP-400 dot-matrix printer. Try as I might I cannot get it to work with any printer drivers (and I have collected a few over the years). What is the correct driver? If you don't know, how would I go about editing or creating a new printer driver for it?

I don't know. People consistently bombard me with requests for printer drivers. I help where I can, but it's a job I'm not prepared to shoulder, mainly because I don't like broken shoulders. OK, you want to have a go yourself? Get *Amiga Printers Inside and Out* by Ralf Ockenfelds, published by Abacus at \$34.95 (prices vary in the UK). The ISBN is 1-55755-087-5, which should help you in tracking down a copy. Read it, understand, learn how to use the supplied disks and months from now you might sort your problem out.

The problem is that there are many dozens of different types of printer, each with its own unique method of control. While many printers share similar codes for control (printer protocols like Epson 9 pin, Postscript, and Hewlett Packard variants) everybody wants their printer to work at its best capability, which means getting a dedicated, correct printer driver as opposed to the supplied ones on the Extras disk which work to a certain extent, but are not up to the high print resolutions available on the latest printers. If anybody wants to set up a driver library, let me know. ☺

Techno Babble

Do you know how to talk techie speak? Well if you don't then this little bit of jargon-busting should sort you out!

Accelerator: hardware expansion that gives your Amiga a faster CPU. Often used with maths-intensive software where a standard processor is too slow, for programs called 'raytracers' which literally trace the rays of light which bounce around a scene to produce a picture. Also used to considerably speed up flight and other kinds of simulations.

Anim Brush: a brush is a small section of a graphic screen, cut out with a paint program like *Deluxe Paint*. Anim brushes are different small images with the same dimensions – for instance, a bird flapping its wings or an eye blinking.

Blitter: BLock Image TRANSFER device. Used for copying large areas of memory from A to B, or to combine different areas into one single image. Widely used to generate large graphic shapes in computer games.

CD-ROM: a storage device for playing compact discs. As well as standard music discs, CD-ROMS can play special computer discs that are massive in capacity compared to normal floppy discs.

Chip RAM: memory accessible by the custom chips (Paula, Agnus, Denise) as well as the processor. Used to store all graphics and sounds. Can be used by programs too – with speed slow downs.

CLI: Command Line Interface. The program which enables you to type commands into AmigaDOS for standard operations like copying files or getting a directory. Shell is more commonly used now.

Copper: co-processor. Used to generate subtly coloured backgrounds – this device is built into the Agnus chip and it can alter colours while the screen is being generated. Executes instructions at the same time as the processor.

CPU: Central Processing Unit. The decision-making chip, the one that tells everything else what to do. It can be interrupted by custom hardware if its programs are in chip RAM.

Fast RAM: memory that's only accessible by the processor. Programs stored here run faster than those in chip RAM – hence the name.

Frame grabber: device for capturing live video data and converting it into computer picture data. Doesn't require a still video signal. Usually gives much better results than a video digitiser, which does the same job, except that the video must be paused.

Freezer cartridge: quasi-legal device for examining programs while they are running. Usually with many useful built-in utilities which help overshadow its dubious origins.

Hard drive: basically a big disk for keeping Workbench and all the serious software that you use. Works much faster than a floppy disk. More and more games are becoming installable on to a hard drive.

IFF: Interchange File Format. A standard way of storing pictures and sounds, it was invented by Electronic Arts and adopted by Commodore. A single standard – practically all art programs can load and save pictures in this form.

Kickstart: the name of the set of programs which are run when the Amiga is turned on. Also contains many library functions for programmer use. Latest is Kickstart 3. Other releases: 2.05, 2.04, 1.3, 1.2, 1.1.

MPEG: Motion Picture Expert Group. A bunch of individuals who set out to find means to store films and video on computer rather than photographic or magnetic means. Still some way off on the Amiga.

PD: Public Domain. Literally, software that is the property of everybody. PD disks can be freely copied by anyone, and you can also distribute them to whoever you want. The correct term is 'Freeware', 'Shareware' (try before you buy) and 'Licenseware' (commercial and non-distributable) also come under the same rough heading.

ROM: Read Only Memory. Memory that cannot be altered. Widely used as the starting programs for computer systems that have just been turned on – ROMs remember things permanently.

RAM: Random Access Memory. Memory that can be altered and re-altered many times. Typically, it does not remember what it contains when the computer's power is switched off.

Script file: a set of commands which you would otherwise have to type into the CLI or Shell by hand. Saved as a text file. Learning how to use Shell or the CLI involves learning how to write script files.

Shell: more up-to-date version of CLI. Works in exactly the same way, but enables some flexibility in what commands are called via the 'alias' function. Also gives some hot-key combinations to enable some editing of previously entered commands.

Sound Sampler: hardware device that converts electrical music signals (typically from a tape or CD player) into computer sound. Can also be used with a microphone to capture live sounds.

Sprite: a graphic object that is independent of the screen. On the Amiga, sprites are limited in size and colours. Typically used for mouse pointers, alien missiles, and so on.

Startup-sequence: the name of the script file, contained in the S directory, which is executed after a disk has booted. Typically contains just the name of a program to auto-run, but can be very complicated. Whatever the nature of the file, it must always be called Startup-sequence and live in the S directory.

Workbench: the set of programs which sets up a graphical 'point-and-click' interface on the Amiga. Much more friendly than the CLI or Shell, but not as flexible. Always has to be loaded from disk, which is slow but does enable much customisation. Workbench 3 requires a Kickstart 3 ROM. Workbench 2 requires a 2 ROM. 1.2 needs a 1.2 ROM and so on.

Zorro: this is the generic name for the Amiga's expansion connector. The A500, A500 Plus and A1000 had the original Zorro I; the A1500s and the 2000s have Zorro II; and the A3000 and A4000 have Zorro III. They are not compatible, hence the different expansions for different machines. The A600 and A1200 have a PCMCIA connector instead.

Ladbroke Computing



33 Ormskirk Rd,
Preston, Lancs,
PR1 2QP

Ladbroke Computing International are one of the longest established home computer dealers in the UK. We have developed an extensive customer service policy which involves testing of all Hardware prior to despatch to ensure that goods arrive in working order, offering free advice and support over the phone and keeping customers informed. Although our prices are not always the cheapest we do endeavour to offer consistently good service and backup.

All prices are correct at copy date 23/11/92 (while stocks last) and are subject to change without prior notice. All prices include VAT but exclude delivery.

How to Pay

You can order by mail Cheques/Postal orders made payable to Ladbroke Computing. Or give your credit card details over the phone.

Delivery

Add £3 for postal delivery (check with staff before ordering)

Add £5 for next working day courier delivery. Add £11 for Saturday courier delivery. (Mainland UK only)

Open Mon-Sat 9:30am to 5:00pm
Ladbroke Computing Ltd Trading As
Ladbroke Computing International

Fax: (0772) 561071

Tel: 9 am - 5:30 pm (5 Lines)

(0772)203166

Printers



Star

Star LC20	£ 124
Star LC100 colour	£ 165
Star LC24/100	£ 179
Star LC24/200 colour	£ 259
Starjet SJ48 Bubblejet	£ 210
SJ48 Sheetfeeder	£ 69

Citizen

Citizen Swift 240 Colour	£ 270
--------------------------	-------

Hewlett Packard

HP Deskjet 500	£ 339
HP Deskjet 500 colour	£ 449

Lasers

Seikosha OP104	£ 549
● 512K RAM (Exp to 2.5Mb)	
● HP Laserjet IIP emulation	
● 14 resident fonts	
● 12 months on site warranty	

Ricoh LP1200	£ 759
--------------	-------

- Fully HP III compatible
- 400Dpi resolution
- 2Mb RAM on board
- Serial & Parallel ports
- 12 months on site warranty

All Star dot matrix printers come complete with 12 months on site warranty. Please add £3 for Centronics cable.

Hand Scanners



- 100,200,300,400 Dpi resolutions.
- 1 letter mode, 3 photo modes.
- Includes two of the most respected graphics packages, MIGRAPH'S TOUCH UP and DELUXE PAINT III.

Golden Image Scanner	£ 99.99
Jin Scanner	£ 89.99
Jin as above but excluding Touch Up.	

GVP II Hard drives

- Quantum SCSI Hard drive
- Ultra fast 11ms access
- Up to 8Mb RAM on board
- Disable switch
- 2 year warranty

52Mb No RAM	£ 329
52Mb 2Mb RAM	£ 369
52Mb 4Mb RAM	£ 429
120Mb No RAM	£ 439
120Mb 2Mb RAM	£ 479
120Mb 4Mb RAM	£ 529
120Mb 8Mb RAM	£ 649
2Mb SIMM upgrade	£ 48
4Mb SIMM upgrade	£ 93
8Mb SIMM upgrade	£ 180

Repair Services

Our Service department can repair Amiga's in minimum time at competitive rates. We can arrange for courier pickup and return delivery of your machine to ensure it's safety. We even have a same day service which will ensure your machine is given priority and subject to fault, completed the same day. We can fit memory upgrades, ROM upgrades. We offer a Quotation service for £15 for which we will examine your machine and report back with an exact price for repair. If you do not wish to go ahead with the repairs then just pay the £15. However if you do go ahead then the charge is included in the minimum charge. Please note: The minimum charge covers labour parts are extra.

Quotation service	£ 15
Min repair charge	£ 35.25
Courier Pickup	£ 11
Courier return	£ 6
Same day service	£ 15
A500 PSU	£ 39.99
Internal drive	£ 39.99

Atari Falcon 030

The Falcon features: 16MHz 32 bit 68030 CPU, 16MHz Blitter, 32MHz DSP 8 channel 16 bit CD quality sound chip, VGA resolution in 65536 colours, Multitasking TOS, Network port, 144Mb floppy, expandable to 14Mb RAM, Stereo microphone input for direct sound digitising, Stereo sound output.

Falcon 1Mb RAM	£ 479.99
Falcon 4Mb RAM 65HD	£ 879.99

Amiga 600 Packs

Amiga A600 £ 269.99
Includes: The new reduced size keyboard, internal modulator, 1Mb on board RAM, Workbench 2.05. Will take smart cards. Also includes 12 months on site Warranty.

Amiga 600 wild, wierd and wicked pack £ 319.99
Includes A600 with Pushover, Microprose Grand Prix, Silly Putty and Deluxe paint III.

A600HD Epic Pack £449.99
Includes A600 with 20Mb internal hard drive and Epic, Trivial Pursuit, Rome Myth

A500 Plus Cartoon Classics £ 274.99
Special Offer while stocks last.

A500 Class of the 90's £ 434.99
Special Offer while stocks last

Mini Office £ 45
Wordprocessor, Database, Spread sheet, Disc Utilities and Graphics.

Compendium Six £ 29.99
A Pack of 6 educational games to encourage creative learning in Maths, Science, Geography and English.

Mice



Golden Image Mouse £ 14.99
The Golden Image Mouse was recently given an Amiga Format Gold Award with 90% and offers 290 Dpi resolution, 2 high quality microswitched buttons and a free mouse mat.

Optical Mouse £ 24.99
The Golden Image Optical Mouse is a high quality, 3 button, replacement mouse. The fully Optical mechanism means no moving parts offering far higher reliability. Includes Mat.

Jin Mouse £ 7.99
Don't be deceived by the low price of this mouse. Mass production of the Jin mouse has resulted in a high quality Opto/Mechanical mouse featuring 290 Dpi resolution.

Ladbroke's Mouse mat £ 2.98
Please add £2 for P&P on mice.

Floppy Drives



- 880K formatted capacity
 - Double sided, Double density
 - Through port
- | | |
|----------------------|---------|
| GI External drive | £ 47.99 |
| Amiga internal drive | £ 39.99 |

GI Brush Mouse



"The Natural way to draw"

- 150Dpi resolution
- Opto/Mechanical mechanism
- 500mm/SEC tracking speed
- Switchable between Amiga/ST
- Direct Mouse replacement.

GI Brush Mouse	£ 19.99
GI Brush + Dpaint III	£ 24.99

RAM Upgrades

A500 512K with clock £ 17.99
The golden image 512K RAM upgrade includes battery backed clock and enable/disable switch.

Xtra RAM A500 + 1Mb £ 49.99
The Xtra RAM for the A500 Plus only, adds 1Mb of chip RAM to the A500 Plus.

A600 Amitek 1Mb with clk £ 42.99
Plugs straight into A600 trap door, compatible with A600, A600HD.

Accessories

50 3.5" disks	£ 20
100 3.5" Disks	£ 38
3.5" Disk head cleaner	£ 4
40 disk box	£ 4.99
80 disk box	£ 7.99
150 Disk box	£ 17.99
A500 Dustcover	£ 3.99
Mouse J/S extension	£ 5.99
PRO Star Mini joystick	£ 14.99

Monitors



Philips 8833MKII £ 225.00
This best selling colour, stereo monitor comes complete with 12 months on site warranty and free Lotus Turbo challenge II.

Philips 15" FST Tv £ 219.99

- SCART input Tv
- 39 channel remote control
- Flat Screen

Philips 15" Cube Teletext £259.99

- SCART input Tv
- 60 channel remote control
- Fasttext teletext
- Flat Screen
- 3 Speaker sound

8833 MKII-Amiga cable	£ 9.99
Philips SCART to Amiga	£ 9.99
8833MKII dustcover	£ 7.99
14" Monitor stand	£ 9.99

Q Could you tell me what the difference is between PAL and NTSC?

A 56 graphic display lines that's what. PAL programs have graphic displays that are taller with more scan lines than NTSC programs. Both PAL and NTSC are television standards for signals – you can't feed a PAL signal into NTSC equipment and vice versa without some alteration to the vertical hold control of your TV or monitor.

What programmers usually do is write their programs to use only the first 200 lines of the screen – that's why there is a blank area at the bottom of the screen. Such a program works fine on both NTSC and PAL Amigas. However, a full PAL screen program won't be so good on an NTSC screen – the bottom sixth or so is off the bottom of the display.

Q I just can't get *Formula One Grand Prix* working on my A4000. You said it was great on that machine, so how did you do it?



Driving round a circuit with all the smoothness a 68040 accelerator provides is the best way to appreciate *FIGP*.

A The way to do it is to disable the CPU caches. Hold down both mouse buttons when the machine is starting up, and then click on Boot Options. There is a little box with 'Disable CPU Caches' written next to it – click on this so that a tick mark appears. Then click on Use. Click on Graphic Options, and select the Enhanced Chip Set (ECS). Then click on Use, finally click on Boot and run the game from floppy. I regret I couldn't work out how to install the game to hard disk using the supplied program.

Q I want to learn how to solder – I don't really have the time to learn electronics, but can you give me a few tips to help with the odd upgrade or broken wire?

A Hmm. All right, here's a deal – if you're under, erm, let's say 18, then don't do it without adult supervision. The fumes from molten solder are very unpleasant and are also a health risk. Get a soldering iron, about 20 watts output at most (smaller irons are better for intricate work) and some resin-cored solder wire. Remember that the iron gets HOT.

Also get some scrap electrical gear – don't use your aunt's beloved Fifties wireless – some electronic scrap like a digital alarm clock or a cassette recorder from a junk dealer will do. A damp sponge is handy for cleaning hot soldering irons, and do get a decent holder for when you need to put the iron down safely. A desoldering pump ('solder sucker') is cheap and very handy for slurping up excess solder.

Make sure no power (even batteries) is going to your piece of electrical junk. Unscrew it and remove the circuit boards, disconnect all wires (but keep them) and connections so you what you have is a circuit board with lots of components soldered in.

Answerfile

Short snippets and extracts to help solve those little, tricky techie problems, all straight from **Pat MacDonald's** keyboard.

Plug in the iron and switch it on. When it is at the right temperature, solder will melt over the tip (the tip end is known as the bit, and you can usually fit a variety of sizes of bit). Congratulations, you've just tinned your bit. Tinning is the art of applying solder.

OK, with your freshly tinned bit, apply it to a likely looking blob of solder on the scrap board. After a short while, the solder will melt, and you can wobble the connector around (if you are frightened of burning your fingers, use a pair of pliers to move the components). Use a desoldering pump to suck away all the excess solder.

Gradually work your way around the components, cleaning the bit on the damp sponge and tinning it again (your bit should always be shiny and clean). Eventually, you'll be able to take out the components, although you'll probably burn the board slightly. Judging the heat of solder takes a while to learn, but is easily mastered – don't hold the iron to the board for long periods of time.

When you've finally managed to get all the components out, try soldering them back in again. Find a different bit of scrap board and repeat the process. Remember those bits of wire I told you to keep? Try stripping off some of the outer insulator, and with the iron and a bit of solder, tin the end.

Eventually, you will become confident enough to have a go at the real thing – a good place to start is making a null-modem cable for two-computer, two-player games. If you start dealing with chips, then anti-static precautions have to be taken (either wear an anti-static wrist strap or keep touching a water pipe every few minutes to avoid static building up which blows your chips). Get a basic electronics book out of the library and learn. Get really good and you may end up with a job.

Q How does a ROM sharer work? Please keep it simple, because I want better compatibility without more confusion!

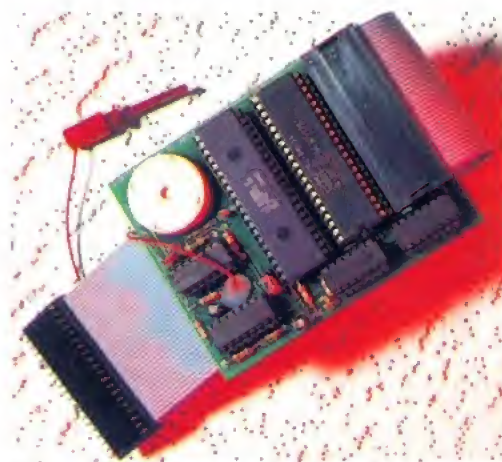

'Ere, I've seen one of these before. It's one of them there Kickstart switchers or ROM sharers.

A Well I'll try to keep it simple-ish. ROM sharers are expansions which can take two or more

Amiga Kickstart ROM chips. The idea is that you take out your present Kickstart chip and plug in the ROM sharer to the empty socket. Then plug the Kickstart into the ROM sharer, plus a different version of Kickstart. By flicking a switch, you can choose whether you want to use Kickstart 1.3 or 2.

Here's the technical version. ROM sharers are small circuit boards with two (or more) sockets, and a set of pins to connect to an Amiga ROM socket. The idea is that you carefully lever out your current ROM chip, and plug it into the ROM sharer. You then plug in a different ROM (Kickstart 1.3 if you already have Kickstart 2, or Kickstart 2 if you already have 1.3) alongside the present one, and plug the ROM sharer into the socket left by your present ROM. Usually there are jumper leads to wire up the change in ROM to a particular mouse button being held down, or the joystick fire-button being pressed, or a particular key being pressed, when the machine is resetting.

Q Why is it that all software doesn't work on the new A1200? Or the A600 and A500 Plus come to that?

A Lots of different reasons, but it all boils down to this – the programmer who wrote the incompatible program did not follow the guidelines on ensuring compatibility with future machines. Now, in the programmer's defence, it has to be said that a lot of the guidelines involve setting up the Amiga using the supplied Commodore routines, which is a bit of a drag and a lot of hassle (plus money for the correct, 'Official' Addison-Wesley guidebooks).

Not many programmers do stick to the standards. When Amigas change (different Kickstarts, Agnus chips, Denise chips) then the homebrew routines which work fine on an A500 tend to fall flat on their faces. The programmers scream 'don't change anything' on the one hand, while at the same time asking for more memory, standard hard disks and CD-ROM drives, better sound and graphics etc.

Q Is it legal to swap games? I mean, one boxed copy for one boxed copy? My friends and I often get bored of games, so is this all right or not?

A First, understand that I'm not legally qualified in any way and the situation varies from program to program, but as I understand things... Strictly speaking, no it isn't. You will find (often embedded in the small legal print in the documentation) that it is illegal to rehire, lend or otherwise give others access to the programs. The idea is that when you buy the software, you are buying a licence to use the product, not the actual software itself.

On the other hand, some software doesn't have any such messages anywhere in the documentation or readable within the program. Check the small print for yourself. Incidentally, this also means that it's illegal to sell your games collection when you sell your computer – second-hand software doesn't exist according to the conditions of sale under which you bought it.

Q I have been told that the Action Replay cartridges do not like Amigas with large amounts of memory. What is the limit?



The Action Replay III cartridge, while a hugely useful utility, does not like excessive RAM expansions.

A For the Action Replay II, 3Mb of RAM. You could go a little beyond this if you are clever, but 4Mb and up is a big no-no – the cartridge will not work. (The same goes for Action Replay III.)

Q Why is there so much computer speak in *Amiga Format*? Why use jargon?

A It's shorthand. Every craft, market, hobby has its own breed of special words and acronyms, to save on ink and get more information into a smaller space. We *do* try to explain jargon where we use it, but what makes jargon unreadable is that the person reading it has no explanations – which means we have to use a bit of discretion about what we explain.

Is RAM a jargon term, or part of Modern English? How about printer? How about scanner? How about floppy disk? Write to Damien the editor via Letters if you think there's too much jargon, or tell me what you don't understand and I'll try to explain.

Q Do you read all the letters you get?

A Yes. If it's addressed to Pat McDonald, Workbench, Answerfile or Amiga Answers via the *Amiga Format* office, I read it. I don't get to answer many of them due to lack of space, but all entries are carefully considered. Usually I answer a mixture of the common and the outlandish.

Q Can I upgrade my Amiga to Workbench 3? Can I just boot a Workbench 3 disk in my present Amiga?

A You cannot boot a given version of Workbench unless you have the relevant Kickstart (turn back to Page 196 and see 'Techno Babble'). It is possible to upgrade A3000s to use Workbench 3, but not (at the present time) any other Amiga that does not already have it.



A3000s are the only Amigas that can upgrade to Workbench 3 and get this fab desktop.

In-depth explanation No 11: AmigaDOS

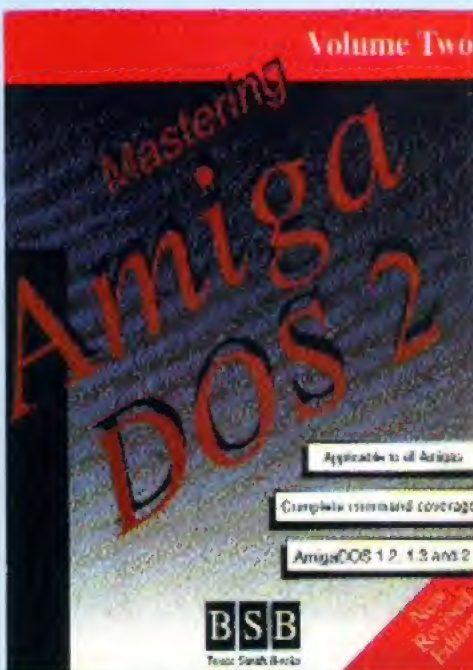

For a copy of the above, simply phone Bruce Smith Books on 0923 894366.

screen scrolling, press any key – press the Delete key to continue with the directory.

5 The AmigaDOS commands in the C directory need a certain amount of housekeeping in order to operate. To put it simply, there has to be a T directory, either on your Workbench disk or, more usually, set up by Workbench in your RAM disk. This T directory is a temporary storage area, used by commands such as Copy, Diskcopy and others. If your computer keeps asking for volume T, then the directory hasn't been set up and the commands cannot work properly. In addition, ENV has to be available, and (on Workbench 2 and above) an ENV-ARC directory. The Clips or clipboard directory has a similar purpose.

6 Rather than continually typing lists of commands into the Shell or CLI, you can instead write a script file with a word processor or a text editor. Such a script file is simply a list of AmigaDOS commands, together with the arguments. An argument for a command is the bit that's not the command name – for instance, List c. List is the command and c is the argument, and refers to the c directory on Workbench. Much more complex arguments can be used when you know your way around AmigaDOS.

7 The most common usage of script files is the startup-sequence file. This lives in the S directory (type list S to have a look) and is a list of AmigaDOS commands. This script is executed automatically when Workbench (or any other AmigaDOS disk) boots.

If you want to have a look at a startup-sequence, then bang this into a Shell or CLI; Type s/startup-sequence. Alternatively you could load the file into a word processor or text editor.

8 Many of the commands in the C directory are only for use in scripts. For instance, the Echo command prints text messages, the If, Then and Else are for making decisions in scripts, and the Jump and LAB commands are for jumping around to a different label in a script file. The point I'm trying to make is that there is a lot of support on Workbench for script writers – but you don't need to know about it in order to use Workbench. It comes in handy when you are trying to customise Workbench, and designing your own disks.

9 Do not think that all the AmigaDOS commands you can get are on Workbench. Many, many Public Domain and shareware commands have been released over the years – utilities for doing things like setting the current font in use, opening a window, clearing the printer channel or testing MIDI equipment, to name but a few of the categories. The most successful commands usually end up being bought by Commodore and placed onto the latest versions of Workbench.

10 AmigaDOS commands have some compatibility between different versions of Workbench, but some won't work on different releases. So, if you try to use the 1.3 Install command on a Workbench 2 machine, it will not work (it usually crashes the machine). This means you have to be careful when making your own disks, because if you use an incompatible command you will prevent some people from using your disks.

1 Operating System; the software that forms a bridge between different elements of the computer (screen, keyboard, programs and so on). The abbreviation is OS. Disk Operating Systems are OSs that can in addition cope with talking to and listening to disk drives (as opposed to older tape-based systems). AmigaDOS is, quite simply, DOS for the Amiga.

2 A lot of people think that Workbench is the same as AmigaDOS. Workbench is not the same – it's a convenient illusion for what is going on in the background. Traditionally, OSs have been controlled through the keyboard. In the mid-Eighties, WIMP (Windows, Icons, Mice, Pointers) systems made computers more accessible, and the Amiga uses all four – you generally use Workbench to use the computer, but for many tasks you have to talk to AmigaDOS directly through the keyboard. To do this, you have to double click on the Shell or CLI icon found on the Workbench disk.

3 Once you are in the Shell or CLI (Shell is nicer, but only available on Workbench 1.3 or later) you will see a number with a prompt. This is the number of the Shell process – you can have up to 20 Shells or CLIs open at the same time. If you want another window, just type NEWCLI or NEW-SHELL and press Return. To get a listing of the current directory, type LIST and hit Return. To get an alphabetical listing (which doesn't show the size of files) type DIR and hit Return.

4 The first name you enter into a Shell line is the name of a program on Workbench. What you are really doing when using Shell is running programs – differently named programs do different things. Most of the commands can be found in the C directory. If you want to have a look at them, type list C (notice that AmigaDOS doesn't care whether or not you use capital letters). To stop the

CALL US NOW ON (0386) 765500 • Evesham Micros

Evesham Micros



PRICES INC. DELIVERY & VAT @ 17.5%

HERE TODAY ~ HERE TO STAY

Evesham Micros First. First for choice, price and service. Established for over nine years, with a strong financial status and secure future. Our Computerised Telesales Order Processing investment means fast, efficient service. Well appointed Retail Showrooms with large product range on display. Our huge Customer database, high percentage of repeat custom and personal referrals underlines our popularity. REMEMBER - when you need us, we will still be here. Our extensive expansion program means we could eventually be there as well...

HOW TO ORDER....

Call us now on
0386 765500

TELESALES OPENING TIMES:
9am - 7pm Monday-Friday
9am - 5.30pm Saturday

Send Cheque, Postal Order or ACCESS/VISA card details to:

Evesham Micros Ltd.
Unit 9, St Richards Road
Evesham, Worcs. WR11 6XJ

ACCESS / SWITCH / VISA Cards Welcome

Government, Education & PLC orders welcome.
Same day despatch whenever possible.
Express Courier delivery (UK Mainland only) £6.50 extra.
Please note that 5 banking days must be allowed for cheque clearance.
Immediate clearance on Bank Drafts.

Credit card orders: We do not charge the card until the goods are despatched.

Mail Order Fax: 0386-765354

RETAIL SHOWROOMS
Normal Opening times: Monday-Saturday, 9.00-5.30
Late Night Opening Until 7pm Wednesday-Friday

EVESHAM Unit 9 St Richards Rd, Evesham Worcs WR11 6XJ ☎ 0386-765180 fax: 0386 765354	BIRMINGHAM 251-255 Moseley Rd, Highgate Birmingham B12 0EA ☎ 021-446 5050 fax: 021 446 5010
--	---

CAMBRIDGE 5 Glisson Road, Cambridge CB1 2HA ☎ 0223-323898 fax: 0223 322883	MILTON KEYNES 320 Witan Gate, Milton Keynes MK9 2HP ☎ 0908-230898 fax: 0908 230865
--	--

TECHNICAL SUPPORT ☎ 0386-40303
Monday to Friday, 10.00 - 5.00

1 YEAR WARRANTY ON ALL GOODS
Details correct at time of going to press • All goods subject to availability

AMIGA SOFTWARE	Digital Wordworth £ 99.00	MR Backup £ 29.95
	King Words 3 £ 49.95	AMOS £ 37.50
	Protext V5.5 £ 120.00	HiSoft Lattice C £ 199.00
	Home Accounts V2 £ 49.00	GFA BASIC Compiler £ 24.95
	Deluxe Paint 4 £ 79.99	Devpac 2.15 £ 44.95
	Deluxe Video 3 £ 84.95	Workbench Management £ 9.95

A500 HARD DISKS

PRICE BREAKTHROUGH!

AT LAST... the chance to buy Quality, High Capacity Hard Disk Systems for the Amiga 500 at realistically low prices!

- ✦ SCSI HARD DISK MECHANISMS for optimum performance, fast Access Time & Autoparking
- ✦ Includes its own DEDICATED PSU. CBM recommends against use of Hard Disks without independent power supply
- ✦ Option for up to 4MB additional easy RAM EXPANSION, using 'SIMMS'
- ✦ COOL... by popular demand, we have fitted a Cooling Fan!
- ✦ GAME SWITCH allows Games to be loaded without disconnection
- ✦ Includes SCSI THROUGHPORT at rear for further expansion
- ✦ High quality metal casing, colour and style matched to the Amiga 500
- ✦ Includes 'MRBACKUP PRO' as well as Configuration/Format software

40Mb MODEL ONLY £ 229
100Mb MODEL ONLY £ 329

2Mb RAM Version: ADD £60 • 4Mb RAM Version: ADD £120



AMIGA 500 SOLDERLESS RAM UPGRADES

A500 512K RAM/CLOCK UPGRADE

ONLY £ 19.99
INC. VAT AND DELIVERY

ALSO WITHOUT CLOCK FOR ONLY:
£ 16.99

- ✦ CONVENIENT ON / OFF MEMORY SWITCH
- ✦ AUTO-RECHARGING BATTERY BACKED REAL-TIME CLOCK
- ✦ COMPACT, ULTRA-NEAT DESIGN

'A500 PLUS' 1MB RAM UPGRADE

THE FASTEST AND EASIEST WAY TO UPGRADE YOUR A500+ TO 2MB RAM!

- ✦ Simply Plugs into trapdoor expansion area
- ✦ Increases total RAM capacity to 2Mb 'ChipRAM'
- ✦ RAM On/Off Switch
- ✦ Compact unit size
- ✦ Only 8 low power RAM IC's
- ✦ High reliability

ONLY £ 37.95

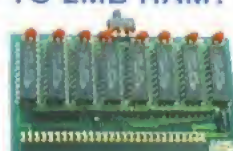

1.5MB RAM BOARD

UPGRADE TO 2MB FOR ONLY £82.99!

Fully populated board increases total RAM in A500 to 2Mb! ✦ Plugs into trapdoor area, & connects to 'GARY' chip ✦ Includes Battery-Backed Real-Time Clock ✦ Socketed RAM ICs on 512K / 1Mb Versions

Unpopulated RAM board with clock £ 34.95
With 15Mb FASTRAM installed £ 62.99

N.B. The expansion board requires Kickstart 1.3 to operate - Kickstart 1.3 upgrade available from us for £29.95

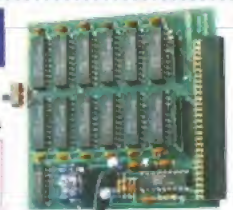

'MEGABOARD'
With our MEGABOARD, you can further expand your A500's memory to a total of 2MB without disposing of your existing 512K upgrade (must be 4 x RAM-chip type, or not exceeding 9cm in length).

CONNECTS TO YOUR 512K RAM UPGRADE TO GIVE 1.5MB

ONLY £ 42.99

MEGABOARD needs Kickstart 1.3 to operate (Kickstart 1.3 upgrade available from us for £29.95). Installation requires connection to the GARY chip. Easy to follow instructions provided.

A500 EXTERNAL RAM UNIT

- ✦ Throughport for further expansion
- ✦ Very low power consumption
- ✦ Style matched to the A500
- ✦ RAM access LED
- ✦ RAM test/run switch
- ✦ Available fitted with 2Mb, 4Mb, or fully populated with 8Mb
- ✦ Optional PSU (allows Amiga to power other devices)



Incorporating the latest 'ZIP' DRAM technology, our new External Memory Upgrade allows the A500 / A500+ to be upgraded by up to a further 8Mb of auto-configuring FASTRAM.

N.B. Any memory fitted to this unit is in addition to that on your machine already, to a maximum of 8Mb on the external unit.

With 2MB fitted...£112.99 with 4MB...£159.99 with 8MB...£259.99

PARTIALLY POPULATED UNITS EXPAND TO 8MB WITH 2MB MODULES. AVAILABLE SEPARATELY AT ONLY £89.99 PER 2MB • OPTIONAL POWER SUPPLY £14.95

Evesham Micros • CALL US NOW ON (0386) 765500 • Evesham Micros • CALL US NOW ON (0386) 765500 • Evesham Micros • CALL US NOW ON (0386) 765500 • Evesham Micros

PRINTERS

Prices Include VAT, Delivery and Connection Cable

ALL EVESHAM MICROS STAR PRINTERS INCLUDE 12 MONTHS ON-SITE WARRANTY

Star LC 20 Successor to LC 10, 4 fonts, 180/44cps	£ 129.99
NEW! Star LC 100 Entry level 9-Pin Colour, 4 fonts	£ 168.03
Star LC 200 9-Pin Colour, 4 fonts, 180/45cps	£ 193.88
NEW! Star LC 24-100 24-Pin, 5 fonts, 192/64cps	£ 196.23
Star LC 24-200 24-Pin, 5 fonts, 192/64cps, excellent features	£ 204.45
Star LC 24-200C Superb 24-Pin Colour, 5 fonts, 200/67cps	£ 269.06
Automatic Sheet Feeder for 10" LC printers (pls state model)	£ 64.95
Star XB24-200 COLOUR 24-pin, 80 col. power printer	£ 368.95
Star XB24-250 132 column version of XB24-200	£ 438.28

Citizen Swift-24E including COLOUR kit	£ 299.99
Hewlett-Packard Deskjet 500	£ 327.83
Hewlett-Packard Deskjet 500C (Colour)	£ 410.08
NEW! Hewlett-Packard Deskjet 550 Colour	£ 527.58
Canon BJ-10EX Inkjet Printer	£ 222.08
Epson LX400 budget 10" carriage 9-pin 180/25cps	£ 139.00
Epson LX4100 24-pin 180/60cps, 8k buffer	£ 205.00
Panasonic KXP11241 updated 24-pin model 300/100cps	£ 279.00
Panasonic KXP2123 good value 24-pin colour model	£ 299.00

TOP VALUE 400dpi HANDY SCANNER

QUALITY SCANNING - AT THE RIGHT PRICE!

At a genuine 400dpi scanning resolution, this scanner produces truly superb quality scans. Has a full 105mm scanning width, variable brightness control and 100 / 200 / 300 / 400dpi resolution. Daatascan Professional Version 3-scanning and editing software allows real-time scanning in either line art or in up to 64 simulated grey scales. Provides powerful editing features and excellent compatibility with most DTP and Paint Packages, eg. Deluxe Paint 4, Touch-Up. Also supplied is The Publisher Desk-Top Publishing package, ideal for incorporating your scanned images into flyers and newsletters.

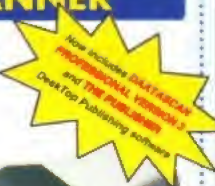

Now includes Daatascan Professional Version 3 and The Publisher Desk-Top Publishing software!

STILL ONLY **£99.99**

TRUEMOUSE



WE GUARANTEE that this is the smoothest, most responsive and accurate replacement mouse you can buy for the Amiga. Excellent performance, now with a 300dpi resolution. Amazing new price!

£14.99 SATISFACTION GUARANTEED

GOLDEN IMAGE OPTICAL MOUSE Amiga/ST compatible - excellent travel+accuracy assured. NEW LOW PRICE!.. **£ 29.00**

TRACKBALL



High performance trackball, directly compatible to any Amiga or Atan ST. Plugs into mouse or joystick port. Super-smooth and accurate - you probably won't want to use a mouse again after using this Trackball! Full one-handed control. Top quality opto-mechanical design, giving high speed and accuracy every time. No driver software needed!

ONLY **£29.95**

NEW! A500 ROM SWITCHER

SWITCHING BETWEEN VERSIONS OF KICKSTART ON YOUR A500 IS EASY WITH OUR NEW ROM SWITCHER!

You can improve software compatibility on your A500 Plus! By fitting our ROM switcher you can alternate between the Kickstart 2 already resident and another version of Kickstart ROM chip, giving you the freedom of choice. Fitting is very simple indeed, and requires no soldering or special technical knowledge. Fitting allows two methods of switching, either by keyboard reset, or by an external toggle switch. N.B. Kickstart ROM not supplied, A500 Revision 5A boards will require circuit modification.

ONLY **£24.95**

Kickstart 1.3 ROM supplied separately	only £29.95
Kickstart 2.0 ROM supplied separately	only £39.95
A500 Revision 5A PCB Circuit Modification Service	£29.95

ZY-FI Amplified Stereo Speakers

REALISE THE TRUE SOUND POTENTIAL

OF YOUR AMIGA WITH THIS PAIR OF FULL RANGE SPEAKERS!



Your Amiga produces fine quality hi-fi stereo sound. Enjoy quality stereo sound reproduction to the full with this new design twin speaker system! Incorporates a built-in amplifier with separate adjustable volume controls for each speaker unit. Runs from PSU (supplied) or from batteries (not included).
Speaker Dimensions 160x95x105mm (HxWxD)

ONLY **£39.95**

AMIGA 600

EXCITING NEW PACKS

STANDARD PACK

With 12 months on-site maintenance
ONLY **£279.99**
2MB RAM/CLOCK VERSION £314.99



WILD WEIRD WICKED PACK

Features: Push-over • Grand Prix • Putty • Delux Paint III • 12 months on-site maintenance
ONLY **£324.99**
2MB RAM/CLOCK VERSION £359.99

EPIC PACK

Commodore's 20Mb Hard Disk version
ONLY **£449.99**
2MB RAM/CLOCK VERSION £484.99

Evesham Micros SPECIAL HARD DISK UPGRADED MODELS

We are now able to supply Amiga A600's with larger hard disks. We take a single drive A600 and install a high quality 2 1/2" IDE hard drive. All models are available with 2Mb RAM - please add £35.00	Please note the hard disk installation is not covered by on-site warranty.	
	60Mb	120Mb
STANDARD PACK	£479.99	£599.99
WWW PACK	£524.99	£644.99

4MB RAM CARD

For any A600.....£149.00

AMIGA 1200

KickStart/Workbench 3.0 • Fast 68020 processor • AGA chipset • CPU/DMA expansion port • PCMCIA expansion slot **£379.99**

UPGRADE YOUR OWN A600 TO HARD DISK

Bring the benefits of a Hard Disk installation to your existing Amiga 600 with our easy to fit upgrades.
60Mb **£229.00**
120Mb **£359.00**

NEW FROM Evesham Micros A600 1MB RAM/CLOCK UPGRADE

UPGRADE YOUR NEW A600 TO 2Mb WITH THIS SIMPLE PLUG-IN MEMORY UPGRADE!

- Simply Plugs into the A600's trapdoor expansion area
- Increases total RAM capacity of A600 to 2Mb 'ChipRAM'
- RAM Enable / Disable Switch
- Battery-Backed Real-Time Clock

ONLY **£39.99**

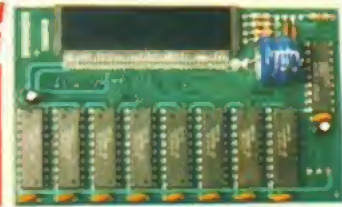

ROCGEN GENLOCKS

OFFERING EXCEPTIONAL VALUE FOR MONEY, the Roggen Genlocks offer levels of quality, function and sophistication not normally available in this price category.



SPECIAL OFFER: ROCGEN MK.II INCLUDES HOME TITLER SOFTWARE FOR A500

GENLOCK MK.II ONLY **£79.99** GENLOCK PLUS ONLY **£119.99**

PHILIPS 15" TV/MONITOR



With its dedicated monitor input, this model combines the advantages of a high quality medium-resolution colour monitor with the convenience of remote control Teletext TV - at an excellent low price! Features dark glass screen for improved contrast, plus full range 3-way speaker sound output.

£269.00 Including VAT, delivery & cable

Philips CM8833 Mk.II Monitor (Genuine UK version), includes cable, 1 Year on-site maintenance and 'Lotus Esprit Turbo 2' game..... **£ 229.00**

ACCESSORIES

Add-on hard drive for A590 external cased unit with power supply	£ 249.00
40Mb	£ 399.00
100Mb	£ 499.00
MIDI interface connects to serial port	£ 19.95
Virus Protector fits to last drive in system, protecting all drives	£ 6.95
VIDI-12 Amiga video digitiser package inc. VIDI-Chrome	£ 110.00
Amiga 500 Dust Cover	£ 4.95
Amiga 600 Dust Cover	£ 4.95

PROFESSIONAL AMIGA REPAIRS

Fixed rate repair service, includes disk drive faults.....£ 54.95
Please contact us on 0386-446441
Please note that we reserve the right to refuse any machine which is beyond economic repair

REPLACEMENT POWER SUPPLIES

Genuine Commodore Amiga A500 type replacement Power Supply Unit. Good quality 'switch mode' type. Super low price!

ONLY **£39.95**

Replacement Power Supply for A590 Hard Disk **£ 49.95**

3 1/2" EXTERNAL FLOPPY DRIVES

AMAZING LOW PRICE!

£47.99
including VAT & delivery

- Very quiet
- Slimline design
- Suits any Amiga
- Cooling vents
- Sleek, high quality metal casing

- Quality Citizen/Sony drive mechanism
- Enable / Disable switch
- Full 880K Formatted Capacity
- Long reach connection cable
- Throughport facility for addition of further drives

REPLACEMENT A500 INTERNAL 3.5" DRIVE KIT



Fully compatible, with 1Mb unfformatted capacity. Straightforward installation procedure. Kit includes full fitting instructions.

ONLY **£39.99**



DYNAMITE COMPUTERS

AMIGA A500 PLUS

1Mb A500 version 2.04 complete with leads, p.s.u. etc.

ONLY £254.95

Above with 2Mb Ram **£279.95**

AMIGA A600 FD

1Mb A600 complete with leads, p.s.u. etc.

PLUS 1 YEARS ON SITE MAINTENANCE

ONLY £254.95

Above with 2Mb Ram (Expansion includes clock)

£284.95

THE WILD, THE WEIRD & THE WICKED

A600 Value Pack from Commodore

includes Deluxe Paint III, Formula 1

Grand Prix, Putty and Pushover

PLUS 1 YEARS ON SITE MAINTENANCE

ONLY £309.95

Above with 2Mb Ram (Expansion includes clock)

£339.95

AMIGA A600 HD

1Mb A600 with 20Mb Hard Drive.
PLUS 1 YEARS ON SITE MAINTENANCE

ONLY £424.95

Above with 2Mb Ram **£454.95**

EPIC/LANGUAGE PACK

A600HD Value Pack from Commodore

includes Deluxe Paint III, Epic, Myth,

Rome and Trivial Pursuit

PLUS 1 YEARS ON SITE MAINTENANCE

ONLY £439.95

Above with 2Mb Ram (Expansion includes clock)

£469.95

A600 80Mb HD PACK

DYNAMITE EXCLUSIVE

1Mb A600 with built-in 80Mb Hard Drive. Complete with leads, etc.

ONLY £499.95

Above with 2Mb Ram (Expansion includes clock)

£529.95

AMIGA 1500

Latest 1Mb 2.04 version complete with mouse, leads, etc. (requires modulator for TV use)

ONLY £479.95

1500 HOME ACCOUNTS PACK

As above plus The Works - Platinum

Edition, Home Accounts, Toki, Elf,

Puzznic & DPaint III

ONLY £524.95

AMIGA 3000

Latest V2, 25MHz, 2Mb Ram, 52Mb

Hard Drive, 3 1/2" Floppy.

Complete with Wordworth 1.1 and

Amiga Vision.

PLUS 1 YEARS ON SITE MAINTENANCE

ONLY £1299.95

Above with 105Mb Drive

£1479.95

AMIGA 4000

New multi-media system 6Mb Ram,

40Mb HD, AmigaDOS 3.

PLUS 1 YEARS ON SITE MAINTENANCE

ONLY £1979.95

Above with 120Mb Drive

£2099.95

A570 CD ROM

CD Drive for A500/A500+

Super low price...

ONLY £259.95

CDTV

CDTV complete with infra-red remote,

leads, etc.

ONLY £354.95

CDTV MULTIMEDIA PACK

As above plus keyboard, infra-red

mouse, 3.5" drive, Workbench Disks,

Welcome CD

ONLY £354.95

MONITORS

GOLDSTAR 14"

TV Monitor complete with remote control & sleep timer

ONLY £154.95

Amiga cable for above **£4.95**

PHILIPS 8833 MkII

Simply the best value stereo colour monitor. UK model complete with 1 year on-site maintenance.

ONLY £169.95

Amiga cable for above **£4.95**

Lotus Turbo Challenge 2 **£6.95**

(when bought with 8833)

CBM 1084S

Commodore's official stereo colour monitor for the Amiga.

ONLY £174.95

Amiga cable for above **£4.95**

CBM 1935

14" SVGA colour monitor .28 Dot Pitch

A MUST FOR A3000/4000

ONLY £254.95

Amiga cable for above **£4.95**

CBM 1960

14" Multiscan SVGA colour monitor .28 Dot Pitch

ONLY £409.95

Amiga cable for above **£4.95**

MONITOR ACCESSORIES

A4 Copy Holder **£3.99**

14" Monitor Dust Cover **£3.99**

12/14" Screen Filter **£6.99**

14" Tilt & Swivel Stand **£9.99**

View Centre/Monitor Stand **£24.95**

View Centre/Control Centre **£29.95**

FLOPPY DRIVES

CUMANA CAX 354

Reputation speaks for itself

ONLY £49.95

POWER PC880E

Solid Drive with anti-click

ONLY £49.95

ROCTEC ROCLITE

New superslim drive now with anti-click & virus checker

ONLY £54.95

POWER PC880B

With anti-click, virus checker and built in blitz copier

ONLY £59.95

HARD DRIVES

GVP HD8 A500

52 Meg Hard Drive **£319.95**

80 Meg Hard Drive **£369.95**

120 Meg Hard Drive **£409.95**

Additional 2Mb Ram for above **£39.95**

Additional 4Mb Ram for above **£79.95**

Additional 8Mb Ram for above **£99.95**

GVP A530 COMBO

52 Meg Combo **£639.95**

80 Meg Combo **£659.95**

120 Meg Combo **£729.95**

213 Meg Combo **£919.95**

GVP HC8 1500/2000

52 Meg Internal **£264.95**

80 Meg Internal **£329.95**

120 Meg Internal **£394.95**

Ram upgrades available for A530

Combo and HC8 internal - Phone for

details.

WITH OUR PRICE BLASTER PLEDGE WE CANNOT BE BEATEN ON PRICE-ORDER NOW

9.30am - 6.00pm ORDER HOTLINE...

0234 214212

MAIL ORDER BARGAINS START HERE!

1

Price Blasters Pledge

Over the past year we have continually provided the best possible price coupled with the best possible service. That's why commencing from November we are introducing the Price Blasters Pledge....

In the unlikely event you are able to purchase any advertised item cheaper elsewhere we will not only match that price but will also send you a £5 Gift Voucher with our compliments*

*Subject to terms and conditions of sale (see page 4)



MEMORY/CHIPS/SPARES

RAM EXPANSION

A500 1/2 Meg no Clock.....	£14.95
A500 1/2 Meg with Clock.....	£17.95
A500 Plus 1 Meg Expansion (upgrades A500 Plus to 2 Meg)	£27.95
A600 1 Meg Expansion no Clock.....	£29.95
A600 1 Meg Expansion with Clock.....	£34.95

ROM SHARER/ROM

Keyboard Rom Sharer.....	£16.99
Keyboard Switchable Rom Sharer.....	£19.99
Kickstart 1.3 Rom.....	£21.99
Kickstart 2.04 Rom.....	£32.99

EXTERNAL RAM UPGRADES

Made by Power Computing
Expandable up to 8 Meg, fully auto-
config with thru-port. Suitable for any
A500/A500+

2 Meg Ram Board.....	£104.95
4 Meg Ram Board.....	£164.95
8 Meg Ram Board.....	£279.95

AMIGA CUSTOM CHIPS

CIA 8520A.....	£6.99
Super Denise.....	£20.99
Fatter Agnes 8372A.....	£29.99

ESSENTIAL SPARES

T.V. Modulator.....	£24.95
Replacement Power Supply.....	£34.95
Replacement Internal Drive.....	£39.95
Replacement Quality Mouse.....	£9.99
Mouse/Joystick Switcher Box Unit.....	£9.99

STAR PRINTERS

LC-20

9 Pin Mono, 180/45 CPS
ONLY £116.95

LC 100 COLOUR

9 Pin Colour, 180/45 CPS
ONLY £149.95

LC 24-100

24 Pin Mono, 192/64 CPS
ONLY £164.95

LC 200 COLOUR

9 Pin Colour, 185/45 CPS
ONLY £166.95

LC 24-20

24 Pin Mono, 180/60 CPS
ONLY £176.95

SJ 48 INKJET

True LQ Printer, 100 CPS
ONLY £194.95

LC 24-200

24 Pin Mono, 220/55 CPS
ONLY £196.95

LC 24-200 COLOUR

24 Pin Colour, 220/55 CPS
ONLY £239.95

CITIZEN PRINTERS

120D+

9 Pin Mono, 120/25 CPS
2 year guarantee
ONLY £107.99

SWIFT 9

9 Pin Mono with colour option,
160/40 CPS
2 year guarantee
ONLY £159.99
Colour version **£166.95**

SWIFT 200

24 Pin Mono with colour option,
180/60 CPS
2 year guarantee
ONLY £189.99

SWIFT 200 COLOUR

24 Pin Colour, 180/60 CPS
2 year guarantee
ONLY £219.95

SWIFT 240

24 Pin Mono with colour option,
200/66 CPS
2 year guarantee
ONLY £249.95

SWIFT 240 COLOUR

24 Pin Colour, 200/66 CPS
2 year guarantee
ONLY £264.95

ESSENTIAL PRINTER ACCESSORY PACK

- Amiga to Printer Cable
- 500 sheets continuous paper
- Universal printer stand
- Printer driver disk

ONLY £9.99
when purchased with printer

**TURN PAGE
FOR MORE
BARGAINS**



BEST POSSIBLE ADVICE, BEST POSSIBLE SERVICE & BEST POSSIBLE PRICE—ORDER NOW

9.30am - 6.00pm ORDER HOTLINE...

0234 214212

CHECK OUT OUR TOP 20 OVERLEAF!

SERIOUS SOFTWARE & HARDWARE APPLICATIONS

SCANNERS

Award winning Power Scanner with latest version 3.0 software.

Extra value pack 1. Includes Wordworth V1.1. Word-processing Package (RRP £129.95)
ONLY.....**£99.99**

Extra value pack 2. Same Scanner including Paint Pack comprising Deluxe Paint 3 and Photon Paint 2 (RRP £139.95)
ONLY.....**£99.99**

Colour Scanner available with either of above packs
ONLY.....**£239.99**

MUSIC

Music X Junior.....**£9.99**
Music X Vers 1.1.....**£17.99**
Pro Midi 4 Port Interface.....**£14.99**
Rombo Megamix.....**£24.99**
GVP Sound Studio.....**£49.99**

VIDEO

Scala 500.....**£69.99**
Scala Professional.....**£179.99**
Take 2 (New enhanced vers)..**£39.99**
Vidi-Amiga 12.....**£74.99**
Vidi-Amiga 12 + Megamix..**£96.99**
Rocgen.....**£84.99**
Rocgen Plus.....**£114.99**
Rocgen Rocky.....**£264.99**

ART

Deluxe Paint II.....**£4.99**
Deluxe Paint III.....**£9.99**
Deluxe Paint IV.....**£54.99**
Spritz Paint.....**£4.99**
Photon Paint.....**£4.99**
Photon Paint 2.....**£9.99**

WORD PROCESSING/DTP

Kindwords Version 3.....**£34.99**
Final Copy 2.....**£59.99**
Wordworth Vers 1.1.....**£39.99**
(Special Purchase)
Pagesetter 2.....**£39.99**
Pro Page Professional.....**£124.99**
Saxon Publisher.....**£179.99**

UTILITIES/BACK-UP

X-Copy Professional.....**£29.99**
(includes Cyclone cartridge)
Action Replay - Latest vers..**£54.99**
Amiga Release 2.....**£76.99**
Blitz Amiga.....**£18.99**



DYNAMITE

QUALITY JOYSTICKS

QUICKJOY

SV119 JUNIOR TURBO
6 micro switches, twin fire...**£3.99**
SV123 SUPERCHARGER
6 micro switches, autofire...**£7.99**
SV126 JETFIGHTER
6 m/s, pilot grip, auto, S/M...**£9.99**
SV125 SUPERBOARD
10 m/s, stopwatch, variable
A/F, S/M.....**£14.99**
SV129 FOOTPEDAL
Ideal for Flying/Driving.....**£19.99**
SV133 MEGASTAR
Steel Shaft, 7 m/s, A/F, S/M..**£19.99**
SV127 TOPSTAR
6 m/s, Pistol Grip, Heavy
Duty.....**£16.99**

BONDWELL - QUICKSHOT

QUICKSHOT 1
Basic Leaf Switch.....**£3.49**
QUICKSHOT 2
Pistol Grip - Classic.....**£4.99**
QUICKSHOT 2 TURBO
Microswitch version.....**£7.99**
APACHE
Leaf switch, Pistol Grip.....**£5.99**
PYTHON 1M
Super Pistol Grip with m/s...**£8.99**

CHEETAH

NEW CHARACTERSTICKS RANGE
Choose from:
BATMAN RETURNS, TERMINATOR 2,
ALIEN 3 AND BART SIMPSON.
Comes complete in amazing
"MOVIE SET" GIFT BOX - IDEAL GIFT
RRP £14.99 - SEE DIEGO'S
SUPERSAVERS
CHEETAH 125+
Industry standard, robust l/s..**£6.99**
MACH 1
Robus Microswitch, steel
shaft.....**£9.99**
STARPROBE
Superb handling, m/s, steel
shaft.....**£11.99**
THE BUG
Beautiful! Available in green/
black.....**£10.99**
BOLLISTICK
Ergonomic hand held,
gives NES/Megadrive owners
a run for their money.....**£6.99**

SOFTWARE

TOP 20 CHARTBUSTERS

1. SENSIBLE SOCCER.....**£17.99**
2. ZOO.....**£17.99**
3. CIVILIZATION.....**£24.99**
4. MONKEY ISLAND 2.....**£26.99**
5. PUSHOVER.....**£17.99**
6. FORMULA 1 GP.....**£24.99**
7. PREMIERE.....**£21.99**
8. BEAST III.....**£20.99**
9. DUNE.....**£21.99**
10. ADDAMS FAMILY.....**£17.99**
11. FALCON.....**£10.99**
12. MAN. UTD.....**£5.99**
13. PGA TOUR+.....**£20.99**
14. TEAM SUZUKI.....**£5.99**
15. GRAHAM TAYLORS.....**£17.99**
16. WIZZKID.....**£17.99**
17. ESPANA GAMES '92.....**£20.99**
18. SPACE CRUSADE.....**£17.99**
19. COOL CROC TWINS.....**£17.99**
20. STRIKER.....**£17.99**

EDUCATIONAL

- FUN SCHOOL 2**
Under 6.....**£6.99**
6 to 8.....**£6.99**
Over 8.....**£6.99**
- FUN SCHOOL 3**
Under 5.....**£14.99**
5 to 7.....**£14.99**
Over 7.....**£14.99**
- FUN SCHOOL 4**
Under 5.....**£14.99**
5 to 7.....**£14.99**
7 to 11.....**£14.99**
- KOSMOS LANGUAGES**
French Mistress.....**£13.99**
German Master.....**£13.99**
Spanish Tutor.....**£13.99**
Italian Tutor.....**£13.99**
- SUPER VALUE PACK**
All four languages.....**£29.99**

ESSENTIAL ACCESSORIES

3.5" DS/DD DISKS

Bulk quality disks, 100% certified,
complete with labels.
Box of 50.....**£19.99**
Box of 100.....**£37.99**
Box of 200.....**£69.99**
Box of 500.....**£159.99**
Box of 1000.....**£319.99**
Branded precision disks made by
top manufacture Dyan. All boxed
in 10's complete with labels,
shrink wrapped - top quality.
Box of 10.....**£4.99**
Box of 20.....**£9.49**
Box of 50.....**£22.99**
Box of 100.....**£42.99**
500 Disk Labels.....**£4.99**
1000 Disk Labels.....**£7.99**

DISK BOXES

10 Capacity Disk Box.....**£1.29**
40 Capacity Lockable Box...**£3.99**
80 Capacity Lockable Box...**£5.99**
90 Capacity 'Banx'.....**£7.99**
150 Capacity 'Posso'.....**£15.99**

CONTROL CENTRES

Manufactured by Premier Micro's
- the leaders in solid control
centres. Made from sheet steel
and epoxy coated to match
A500/A600.
Comprises of monitor platform
plus shelf to store extra drives,
etc. A500 version complete with
extension leads for joystick/mouse
ports.
A600 version.....**£27.29**
A500 version.....**£32.99**

MICE & TRACKER BALLS

Squik Quality Mouse.....**£9.99**
Roctec Mouse.....**£12.99**
Golden Image Happy Mouse..**£18.99**
Golden Image Brush Mouse..**£23.99**
Naksha Mouse.....**£23.99**
Golden Image Optical Mouse..**£28.99**
Zydec Trackerball.....**£28.99**
Golden Image Crystal Trackerball..**£35.99**
8mm Mousepad.....**£3.99**
Optical Mouse Mat.....**£8.99**

NONE OF OUR COMPETITORS COME CLOSE - WHY PAY MORE? - ORDER NOW

9.30am - 6.00pm ORDER HOTLINE...



DYNAMITE BLASTS AWAY THE COMPETITION

COMPUTERS



CHECK OUT DIEGO'S TOP 10 Christmas Supersavers

1

CHEETAH CHARACTERSTICK JOYSTICK

The perfect gift, available as either:

- ★ Batman Returns ★ Terminator 2
- ★ Alien 3 ★ Bart Simpson

Complete in movie set gift pack! ONLY **£8.99**

2

TAILOR MADE AMIGA 500 DUSTCOVER

A steal at just... **£1.99**

3

DISK ACCESSORY PACK

- ★ Box of 10 branded precision disks
- ★ 40 capacity lockable disk box
- ★ 3 1/2" disk drive cleaner kit

ALL FOR ONLY **£8.99**

4

GFA BASIC (RRP £49.95)

Essential for programming

£3.99

5

6mm QUALITY MOUSEPAD

At this price you can't go wrong

£1.29

6

SEGA MEGADRIVE

Basic console with joypads & p.s.u.

£99.99

7

ZIPSTICK SUPERPRO JOYSTICK

Simply the best autofire joystick on the market

ONLY **£9.99**

8

ASTRA TEN GAME PACK

- ★ Datastorm ★ Dungeon Quest ★ E.Motion ★ Grand
- ★ Monster Slam ★ Powerplay ★ RVF Honda
- ★ Shufflepuck Cafe ★ Soccer ★ Tower of Babel

ALL 10 GAMES FOR ONLY **£14.99**

9

CARTOON CLASSICS GAME PACK

- ★ Bart Simpson ★ Captain Planet
- ★ Lemmings

£14.99

10

AMIGA 1.3 BUSINESS PACK

- PRO WRITE 2.5 (Wordprocessor)
- MAXIPLAN (Spreadsheet)
- INFOFILE (Database)

ONLY **£24.99**

HOW TO ORDER



Call us NOW on

0234 214212



Send Cheque or Postal Order to
DYNAMITE COMPUTERS
19 Upper Priory St
Grafton Industrial Estate
Northampton

NB: Please write cheque guarantee card number on the reverse of cheque to ensure same day clearance (cheques without card number subject to 10 day clearance). Call into our showroom for a fast and friendly service

Retail/Queries **0234 364428**

DELIVERY CHARGES*

£2.95 for orders less than £100
£4.95 for orders over £100

Next day express service £7.50
Saturday delivery only £15.00

*Charges applicable to UK mainland only

PLATINUM SERVICE CARD

Only £19.99!

Features:

- Next day courier delivery
- 30 day exchange for new
- 1 year guarantee giving free collection and delivery should a fault occur

TERMS & CONDITIONS:

- Price pledge only applicable to individual items over £50 where the price differential exceeds £1.
- Price pledge applicable to goods on a like-for-like basis and currently stocked by competitor.
- Gift voucher may not be redeemed for cash. May only be used in future purchase where normal delivery charges will apply.
- Goods all subject to availability, E&OE.
- All prices subject to change without notice.
- Platinum card is non-refundable and covers only one item.
- This does not affect your statutory rights.

ORDER FORM

Name

Address

Postcode Tel

Access/Visa No

Expiry date

Goods ordered

Delivery

Total

WE GUARANTEE YOU CAN'T BUY CHEAPER THAN DYNAMITE—ORDER NOW

9.30am - 6.00pm ORDER HOTLINE...

0234 214212

GO ON TREAT YOURSELF!

New Horizon Computers

The Hard Drive Specialists

A600 & A1200 Hard Drives

The ESSENTIAL add on for all
SERIOUS Amiga users.

Upgrade your A600 or A1200 with a brand new internal IDE Hard Drive. All our Special installation Kits come complete with fully formatted IDE Hard Drive, cable, mounting kit and fitting instructions.

All New Horizon Hard Drives are sourced from Brand Name suppliers and have been fully tested for 100% compatibility with the Amiga A600 and A1200.

UNBEATABLE PRICES

★ 20 MEG	£120.00
★ 40 MEG	£180.00
★ 60 MEG	£200.00
★ 80 MEG	£250.00
★ 120 MEG	£330.00

A600's & A1200's & PCMCIA CARDS
NOW IN STOCK
PHONE FOR LATEST PRICES

SPECIAL OFFER

For A600 & A1200 Owners

New Horizon will collect your machine, fit the drive of your choice and return your machine by overnight carrier to any mainland UK address for a fully inclusive price of only £38.50. Offer lasts till Feb 20th 1993 only. Phone our Sales Hotline for further details.

A600HD Owners - Upgrade to a bigger drive. Phone for more details.

Hard Drives fitted by us are delivered formatted and partitioned.

Installing a Hard Drive will invalidate your Commodore Warranty so all Computers fitted with a New Horizon Drive are covered by our own Full 12 Month RTB Warranty from date of purchase.

HOW TO ORDER

1. By Phone 
FREE next working day delivery on all items shown and for Credit Card orders placed before 3pm (UK Mainland only). Saturday delivery add £10.00.

2. By Post 
Send a cheque or bankers draft made payable to "New Horizon Computers" and post with your order to :

New Horizon Computers,
Mail Order Dept
High Hope, Lea,
Ross on Wye,
Herefordshire HR9 7LN.

Remember, when you buy from New Horizon Computers you receive :

- ★ Fully Inclusive Prices
- ★ No Hidden Extra's
- ★ Free Next Day Delivery
- ★ Full Technical Support
- ★ Full After Sales Service



CREDIT CARDS
WELCOME



New Horizon Computers, High Hope, Lea,
Ross on Wye, Herefordshire, HR9 7LN
Tel : 0989 750260 Fax : 0989 750337

SALES HOTLINE 0989 750260 TECHNICAL HELP 0989 750337

Wolfpack £7.99

0908 379550

Omnicon Conspiracy £5.99

Flight of the Intruder.....	£9.99
Football Crazy.....	£12.99
Lure of the Temptress.....	£14.99
Ninja Warriors.....	£5.99
Gemini Wing.....	£5.99
Predator 2.....	£5.99
Back to the Future 2.....	£5.99

Jimmy White Snooker.....	£14.99
Dune.....	£14.99
Megalomania.....	£9.99
Silk Worm.....	£5.99
Jaguar XJ220.....	£9.99
Cisco Heat.....	£7.99
Narc.....	£5.99

Pit Fighter £9.99

BLANK DISKS

100% CERTIFIED FULLY GUARANTEED
 20£8 100£30
 50£17 250£70

(PLEASE ADD £2.00 P&P ON ALL BLANK DISK ORDERS)

FOOTBALL CRAZY

KICK OFF 2/PLAYER MANAGER/FINAL WHISTLE

ONLY £9.99

Dungeon Master Only £9.99

AUNT ARCTIC ADVENTURE	£5.99	PREDATOR 2	£5.99
PAPERBOY 2	£6.99	MEGALOMANIA	£8.99
NARC	£5.99	GREMLINS 2	£5.99
UNTOUCHABLES	£5.99	MIGHTY BOMB JACK	£5.99
FLIGHT OF THE INTRUDER	£9.99	MOUSE MATS	£2.00
MEGA BLASTER JOYSTICK	£5.99	PHOTON PAINT 2	£7.99
NIGHTBREED	£5.99	NAVY SEALS	£5.99
FIGHTER JOYSTICK	£5.99	WILD WHEELS	£5.99

LANGUAGE LEARNING PACK

SPANISH TUTOR	RRP £19.99
FRENCH MISTRESS	RRP £19.99
GERMAN MASTER	RRP £19.99
ITALIAN TUTOR	RRP £19.99

ALL 4 FOR ONLY £19.99

10 GREAT GAMES £9.99

ZYDEC EXTERNAL DRIVE £49.99

A300 Air Bus	21.99
Address Family (1 Meg)	15.99
ADI English (11-12)	15.99
ADI English (12-13)	15.99
ADI Maths (11-12)	15.99
ADI Maths (12-13)	15.99
Advantage Tennis	10.99
Agony	10.99
Air Bucks	17.99
Air Sea Supremacy (Gunship, Silent Service, Fly Wings, Carrier Command)	19.99
Air Support	16.99
Alan Bread (Special Edition) (1 Meg)	8.99
Alex (Light Phaser Game)	9.99
Amnos	7.99
Amos (Games Creator)	20.99
Amos 3D (Requires Amos)	22.99
Amos Compiler (Requires Amos)	19.99
Amos Easy (First Steps to Programming)	22.99
Amos Professional (The Ultimate Amos Programming Tool)	44.99
Apidae	16.99
Aquatic Games	19.49
Arabian Nights	15.99
Archer MacLean's Pool	17.99
Arkanoid 2	8.49
Armatyite	3.99
Armour Geddion	3.99
Armour Geddion 2	19.49
Ashtes of the Empire	23.99
Assassin (1 Meg)	17.49
AV8B Harrier Assault	24.99
B17 Flying Fortress	22.99
Barbarian 2 (Prognosis)	14.99
Bar 2	22.99
Batman the Movie	3.49
Battle Ace (HOP)	10.99
Battle Isle Data Disk	14.99
Beach Volley	8.49
Bill's Tomato Game	15.99
Birds of Prey (1 Meg)	22.99
Black Crypt	10.99
Blue Max	19.99
Blues Brothers	8.99
Breach 2 (Enhanced)	18.49
Business Pack for Amiga - Wordworth Processing, K-Spread 2, Spreadsheet and K-Data Database	64.99
Cadaver	8.99
Captive	8.99
Castles (1 Meg)	19.49
Castles Data Disk	11.99
Caesar	19.49
Celtic Legends	19.99
Championship Manager	19.99
Chess Engine	19.99
Clout Attack (Lotus, Sprint, Ghoulis TV Ghosts, James Bond, Venalix the Fly trap)	19.49
Chuck Back	3.99
Chuckie Egg	9.99
Chuckie Egg 2	9.99
Civilization	22.99
Cool World	14.99
Computer (MS/Scroll)	3.99
Crazy Card 3	16.99
Creeper	19.49
Curse of Enchantia	17.99
Curse of the Azure Bond (1 Meg)	17.99
Cyber Assault (Light Phaser Game)	9.99
C-Yron	18.49
D-Generation	10.99
Dark Queen of Nyinn (1 Meg)	21.99
Darkness (1 Meg)	15.49
Death Knight of Nyinn (1 Meg)	19.99
Deluxe Paint 3 (with Animation)	34.99
Deluxe Paint 4 (1 Meg) (Ham Mode & Animation)	34.99
Disney Animation Studio	49.99
Doodlebug	13.99
Dune	19.99
Dungeon Master & Chaos Strikes Back (1 Meg)	19.49

Dyna Blasters	19.99
Elf	18.49
Elex 2 - Jewels of Carbunel (1 Meg)	22.99
Escape - The Games 92 (1 Meg)	19.49
Exile	18.49
Eye of the Beholder (SD)(1 Meg)	19.99
Eye of the Beholder 2 (1 Meg)	23.99
F16 Strike Eagle 2 (1 Meg)	14.99
F10 Stealth Fighter	14.99
Fables & Fables Legend of Kyrandia	19.99
Fantastic Works (Beetles, Pirates, Mega Lo Mania, Populous, Wonderland)	23.99
Fantasy Pak (Colorado, Boston Bomb Club, Crystals of Arborea)	13.99
Final Copy 2 Word Processing	69.99
Final Flight	16.99
Fire & Ice	16.99
First Samurai & Mega Lo Mania	13.99
Flame of Freedom (Midwinter 2)	19.49
Formula 1 Grand Prix	23.99
Fun School 2 (8-5)	7.99
Fun School 2 (6-8)	7.99
Fun School 2 (8+)	7.99
Fun School 3 (8-5)	16.99
Fun School 3 (5-7)	14.99
Fun School 3 (7+)	16.99
Fun School 4 (8-5)	16.99
Fun School 4 (5-7)	16.99
Fun School 4 (7+)	18.99
Gauntlet 2	7.99
Goblins	18.99
Golden Axe	8.49
Golf World Class Leaderboard	7.99
Graham Gooch World Class Cricket	17.99
Graham Taylor's Soccer Manager	18.99
Gunship 2000	21.99
Gun Spy	19.49
Hercules	12.99
Harpoon Y1 21	22.99
Head Over Heels	8.49
Head Over Head	21.99
Heart of China (1 Meg)	22.99
Handball (1 Meg)	11.99
Herzogot + Data Disk	19.49
Hitch Hiker Guide	8.99
Hollywood Collection (Robocop, GhoulFisters 2, Indiana Jones Action, Batman the Movie) (HOP)	9.99
Home Accounts 2	37.99
Home Alone	16.99
Hook	15.99
Humans	17.99
Ian Botham's Cricket	19.49
Ik	8.49
Indiana Jones 2 Adventure (Taz of Atlantis)	23.99
Indiana Jones Adventure	9.99
Indy Heat	16.99
Interceptor - Renegade Legion	10.99
International Rugby Challenge	17.49
International Sports Challenge	10.49
Ishar - Legend of the Forbess	15.99
Jack Nicklaus Golf	8.99
Jaguar XJ200 (1 Meg)	14.99
James Bond	7.49
James Pond 2 - Robocod	18.99
Jet Set Willy	9.99
Jim Power	18.99
Jimmy White Snooker	14.99
John Barnes European Football	16.99
John Madders (UB) Football	16.99
KGB	19.99
Kick Off + Extra time disk (HOP)	3.99
Kick Off 2 (1 Meg)	9.99
Kick Off 2	9.99
Kick Off 2 Final Whistle	9.99
Kick Off 2 Giants of Europe	7.99
Kick Off 2 Return to Europe	7.99
Kick Off 2 Winning Tactics	7.99
Kick Off 3	16.99
Kidtype Junior Word Processor	14.99
Kind Words 3 Word Processor	29.99
Knightmare	19.99

Knights of the Sky (1 Meg)	28.99
Last Ninja 2	5.49
Leander	10.99
Leisure Suit Larry 3 (1 Meg)	25.99
Lemmings	12.49
Lemmings 2	20.99
Lemmings Data Disk - Oh No!	9.99
Lethal Weapon	18.99
Lombard RAC Rally	8.49
Lotus 3 - the Final Challenge	17.49
Lotus Turbo Challenge 2	11.99
Lure of the Temptress	19.99
Magic Pockets	16.99
Manchester United Europe	9.99
Manic Miner	9.99
McDonald's Land	17.49
Mega Sports (Summer games 1 & 2, Winter Games)	16.99
Melinda Maths (7-11)	18.99
Micro English (6 years to GCSE, Conforms to National Curriculum)	19.99
Micro French (Beginners to GCSE and Conforms to National Curriculum)	15.99
Micro German (Beginner to GCSE and Business, Conforms to National Curriculum)	18.99
Micro Maths (11 Yrs to GCSE Conforms to National Curriculum)	15.99
Microprime 3D Golf	19.99
Midnight Resistance	9.49
Midwinter	15.99
Mini Office (Word Processor, Spreadsheet, Database, and Disk Utilities programs)	38.99
Monster Pack 2 (Killing Game Show, Awesomic, Beast 2)	13.99
Motorhead	11.99
New Zealand Story	8.49
Nigel Mansell's World Championship Office Word Processor, Spell Checker, spreadsheet & statistics, Database, Graphics and BasicDPF	44.99
Operation Wolf	8.49
Pacmania	9.99
Page Setter 3.0 DTP	34.99
Pagestream 3.2 DTP	131.49
Paint 'N' Create (Educational Art Package for kids over 6 years)	18.99
Panic	8.49
Paradise Stars	15.99
Pen Pal Word Processor	34.99
Perfect Denial	22.99
PGA Tour Golf + Courses	19.49
PGA Tour Golf Course Disk	11.49
Pinball Dreams (1 Meg)	16.49
Pitchlighter	9.99
Plan 9 From Outer Space	22.99
River Master	8.49
Roots of Darkness	21.99
Populous & Sim City	16.99
Populous 2	18.49
Populous 2 (1 Meg)	19.49
Populous 2 + Data Disk	21.99
Populous 2 Challenge Data Disk	11.99
Power Up (Chase H.Q., Turanic, X-Out, Albert Beck, Rainbow Islands) (HOP)	9.99
Powermonger	19.49
Powermonger World War 1 Data Disk	11.49
Premiere	15.49
Prince of Persia (1 Meg)	9.99
Pro Tennis Tour 2	10.99
Project X (1 Meg)	18.99
Protot Version 4.3 Word Processor	33.99
Push-Over	16.99
Quest & Glory (Woodwych, Midwinter, Gateway, Red)	13.99
Question 2 (351)	24.99
Ragnarok	23.99
Railroad Tycoon (1 Meg)	219.99
Rampart	15.99
Reach for the Skies	19.99
Red Baron (1 Meg)	22.99
Rise of the Dragon (1 Meg)	22.99
Risky Woods	18.99
Road Rash	19.49

4D Driving.....	5.99
Back to the Future 2.....	5.99
Hunt for Red October 2 ..	5.99
Back to the Future 3.....	5.99
Cricket 1 Meg.....	5.99
Tetris.....	5.99
Rugby.....	5.99
Bombozal.....	5.99
Monty Python.....	5.99
Kick Off 2.....	5.99
Welltris.....	5.99
Soccer Mania.....	5.99
Cadaver.....	5.99

Race Driving.....	5.99
Ant Heads.....	5.99
Navy Seals.....	5.99
Dark Man.....	5.99
Player Manager.....	5.99
Viz.....	5.99
Continental Circus.....	5.99
Chronquest 2.....	5.99
Magnetic Scrolls Collection (3 Games).....	5.99
Xenon 2.....	5.99

EDUCATIONAL

SHAPES AND COLOURS.....	£5.99
FIRST LETTERS.....	£5.99
TELLING THE TIME.....	£5.99

0908 379550

BUY ANY THREE £5.99

GAMES FOR ONLY £15.00 !!

SOME GAMES MAY NOT YET BE AVAILABLE BUT WILL BE SENT ON DAY OF RELEASE.

NAME

ADDRESS

POSTCODE

TELEPHONE

ITEM.....

ITEM.....

ITEM.....

ITEM.....

ALL PRICES INC VAT

TOTAL..... £

CREDIT CARD NO:

CARD EXPIRY NUMBER:

SIGNATURE.....

TEL: 0908 379550

DIRECT SOFTWARE LTD,
 UNIT 3, CROSS KEYS SHOPPING
 MALL, ST NEOTS,
 CAMBRIDGESHIRE
 PE19 2AU

DIRECT

UNIT 3 • CROSS KEYS SHOPPING MALL • ST NEOTS • CAMBRIDGESHIRE • PE19 2AU

TEL: 0908 379550 (SHOP PRICES MAY VARY)



E&OE

MJC COMPUTER SUPPLIES

Suppliers of Discount Software since 1984

Educational, Local Authority and government orders welcome, European orders please call or write for a quotation. All goods subject to availability, prices subject to change without notice. E&OE.

Prices include VAT and delivery by post.
Courier delivery available on request.
Please allow 5 days for cheque clearance.

TO ORDER: Credit card orders can be placed by calling the telephone number below - or send a cheque/PO's made out to MJC Supplies to:

MJC SUPPLIES (AF)
Unit 2 The Arches, Icknield Way,
Letchworth, Herts. SG6 1UJ.
Tel: (0462) 481166 (6 lines)

AMIGA COMPUTERS

NEW - AMIGA 1200

The very latest Amiga computer - now offers twice the processing speed at 14.9Mhz, 2 Mbyte of Chip Ram as standard, the new AA enhanced chip set offering up to 16 million colours, a full 96 keys with numeric keypads, Workbench 3.0 and 12 months On-site warranty.

MJC PRICE £CALL

(price includes free courier delivery)

AMIGA 600

The "portable" Amiga, features surface mount technology for greater reliability and Workbench 2. Comes with 12 months On-site warranty.

MJC PRICE £271.00

(price includes free courier delivery)

AMIGA 600 HD EPIC PACK

Amiga 600 with a genuine Commodore 20 Mbyte hard drive fitted. The Epic pack comes complete with four games, Deluxe Paint 3 and an Amiga Easy Text Word Processor

MJC PRICE £429.95

(price includes free courier delivery)

PLEASE NOTE: All the above computers are genuine UK models with nothing taken out of the packs. All come with 12 months On-site warranty and free courier delivery.

AMIGA STARTER PACK

Includes: 10 disks, 40 capacity disk box, joystick, dust cover and Mouse mat.

MJC PRICE £19.95

(Or just £15.95 if purchased with an Amiga)

AMIGA 600 CONTROL CENTRE

Manufactured by Premier Micros these are made of sheet steel and epoxy coated to exactly match the 600. They are precision made to fit the 600 and offer a perfect base for a monitor and a shelf for your extra disk drive or peripherals.

MJC PRICE £34.95

(Or just £29.95 if purchased with an Amiga 600)

A600 1 MEGABYTE EXPANSION

Increase your memory to 2 Mbyte.
Includes Clock.

MJC PRICE £44.95

(Or just £39.95 if purchased with an A600)

EDUCATIONAL SOFTWARE

THE FUN SCHOOL RANGE

Probably the best selling educational software for the Amiga. Fun School 3 and 4 also conform to the National Curriculum

Fun School 3 for Under 5	£15.95
Fun School 3 for 5-7 years	£15.95
Fun School 3 for over 7	£15.95

Fun School 4 for Under 5	£15.95
Fun School 4 for 5-7 years	£15.95
Fun School 4 for Over 7	£15.95

FUN SCHOOL SPECIALS

In response to consumer demand a range of FUN SCHOOL SPECIALS have been developed to help children with specific areas of learning.

Merlin's Maths	£17.95
Spelling Fair	£17.95
Paint and Create	£17.95

LAUGH AND LEARN WITH ADI

The ADI series is aimed at being fun to use as well as being a serious educational tool. Each package is specifically designed to follow the National Curriculum for a particular school year.

ADI - English 11/12 years	£17.95
ADI - English 12/13 years	£17.95
ADI - English 13/14 years	£17.95
ADI - Maths 11/12 years	£17.95
ADI - Maths 12/13 years	£17.95
ADI - Maths 13/14 years	£17.95
ADI - Maths 14/15 years	£17.95
ADI - French 11/12 years	£17.95
ADI - French 12/13 years	£17.95
ADI - French 13/14 years	£17.95
ADI - French 14/15 years	£17.95

KOSMOS SOFTWARE

Kosmos software produce a superb range of educational software including the Answerback Quiz programs and four foreign language aids as well as the hugely popular Maths Adventure.

Answerback Junior Quiz (6-11 years)	£14.95
Answerback Senior Quiz (12 to Adult)	£14.95
Factfile Spelling (requires Junior Quiz)	£7.95
Factfile Arithmetic (requires Junior Quiz)	£7.95
French Mistress	£14.95
German Master	£14.95
Spanish Tutor	£14.95
Italian Tutor	£14.95
Maths Adventure	£17.95

LCL SOFTWARE

Primary Maths Course (3-12 years)	£18.95
Micro Maths (GCSE Level)	£18.95
Micro French (GCSE Level)	£18.95
Micro English (GCSE Level)	£18.95
Micro German (GCSE Level)	£18.95
Reading & Writing Course (3 years+)	£18.95

COOMBE VALLEY SOFTWARE

This is a range of excellent educational adventure games for various ages.

Maths Dragons (5-12 years)	£12.95
Cave Maze (8-13 years)	£12.95
Reasoning With Trolls (5-12 years)	£12.95
Fraction Goblins (8-13 years)	£12.95
Picture Fractions (7-10 years)	£12.95
Tidy The House (5-9 years)	£12.95

KIDDY'S PLAYTIME

A complete entertainment and learning package for young children. Contains 10 exciting programs which include a full Junior Art package, Noddy's Paint Pot, Post Office, Market Place and many more. (1 Mbyte Required)

MJC PRICE £18.95

AMIGA SERIOUS SOFTWARE

AMOS - THE CREATOR

Easy Amos - Simple but powerful	£22.95
Amos v1.2 The original language	£31.95
Amos Compiler	£19.95
Amos 3-D	£21.95

NEW - AMOS PROFESSIONAL

An enhanced version of the very popular Amos program. Contains over 200 new commands. 650 page brand new manual and many more new features.

MJC PRICE £44.95

MINI OFFICE AMIGA

Great new integrated package featuring a Word Processor, Database, Spreadsheet, Graphics and Disk Utilities.

MJC PRICE £39.95

VIDI AMIGA 12

Vidi Amiga 12 is the latest low cost colour digitiser from Rombo. RGB Splitter is built in and colour images can be captured in less than a second. Mono images are grabbed in real time. Features multi tasking software, composite or S-VHS Input, HAM, EHB and overscan.

MJC PRICE £75.95

NEW - WORDWORTH 2

The latest version of this very popular Word Processor. Now includes 17 Compugraphic fonts, it produces silky smooth on-screen fonts at any size. Columns, New tool bar, Indexing, Table of contents, Lists, improved mail merge and many more new features.

MJC PRICE £74.95

Protex V4.3	£39.95
Pen Pal V1.4	£37.95
Kindwords 3	£32.95

MISCELLANEOUS

Pro Midi Interface	£19.95
Stereo Master	£29.95
Rombo Megamix Master	£28.95
Rombo Take 2	£39.95
Pagesetter 2 (requires 1 Mbyte)	£39.95
Hisoft Devpac 3	£49.95
Hisoft Highspeed Pascal	£69.95
Final Copy 2	£65.95
Deluxe Paint V4.1	£54.95

FINANCIAL

Home Accounts 2	£36.95
Personal Finance Manager Plus	£29.95
Maxiplan 4	£34.95

AMIGA ACCESSORIES & ADD-ONS

ACTION REPLAY Mk3

MJC PRICE £54.95

NAKSHA UPGRADE MOUSE

280 DPI quality replacement mouse - Pack includes Mouse House, Mat and Operation Stealth game.

MJC PRICE £22.95

ZYDEC SECOND DISK DRIVE

Excellent value external drive for the Amiga. Includes free Virus X Utility.

MJC PRICE £52.95

ROBOSHIFT

Auto sensing joystick/mouse switch box.

MJC PRICE £13.95

QUICK REPLACEMENT MOUSE

Great value replacement mouse.

MJC PRICE £12.95

VISA

Remember - prices include VAT & delivery!

Access

"..Excellence 3 is not far off being the best document processor for the Amiga...."

Amiga Format Nov. '92



excellence!TM

Version 3
1-MB REQUIRED

NEW FEATURES

- User Specified Automatic Timed Saves
- Support for the ECS high resolution productivity mode
- French and German Spelling Checker Support
- Applcon/AppMenuItem for Workbench Support
- Up To 8 Columns Per Page
- Automatic Palette Correction
- 16 Colour Screen Support
- Document Reading with the Amiga speech Device
- Adjustable Cursor Options
- Customizable Grammatical Checker
- User Definable Colour Elements
- Improved Ruler With Many New Features
- Multiple Backups (number is user specified)
- New ASL Compatible Font/File Requesters
- ARexx Support
- Bookmark Support
- AGFA/Compugraphic Outline Font Support
- Modern AmigaDOS 2.04 compatible Interface (will operate for AmigaDOS 1.3)

ACCESSORIES

- 140 thousand word Dictionary with legal, medical, technical, scientific, geographical and biographical supplements.
- 1.4 million word Thesaurus (with definitions)
- User dictionary maintenance utility
- Spell-as-you-type
- Grammar and Style checker
- Bullet proof Hyphenation
- Glossary with Macro key support
- Safe exit from program saves Glossary changes
- Safe exit from documents for no lost date
- Macros can be assigned to almost any key
- Math
- Paragraph sorting
- Index and Tables of Content generation
- Full word Indexing

PRINTING

- 100% colour Postscript support
- 4 types of printer output, special HP support
- Internal printer font support
- Mail Merge
- Preferences printer driver compatible
- Mixed mode printing
- Landscape printing
- Documents can be printed to disk files for transfer to service bureaux and electronic mail systems

GRAPHICS

- Mix pictures with text in paragraph
- Graphics in headers, footers or footnotes
- WYSIWYG editing
- Picture scaling and cropping

FORMATTING

- Mouse and keyboard support
- Left, Justified, Centered & Flush paragraph
- Left, Justified, Centered & Decimal tabs
- Multiple Headers, footers and Footnotes (odd and even headers and footers)
- Cut, copy and paste Headers, Footers and Footnotes
- Global font and style substitutions
- Page and Ruler settings stored in document
- User defined Page Setup and Print faults
- Direct input of paragraph leading value
- Display current date and time in document
- Automatically numbered footnotes
- Insert retains all text and codes
- Text files retain tab characters

OTHER FEATURES

- Typing speed exceeds 170 words per minute
- IFF and ASCII file import
- Document summary for quick statistics
- Free Technical Support for registered users
- Clipboard support
- Easy insertion of foreign characters
- Not copy protected
- Undo typing
- Metric file conversion utility
- Hard drive install utility
- Verification utility insures disks are perfect
- Markers and Margins may be separately hidden
- Project icon support
- Up to 250 fonts in a single document
- Reads Scribble! files
- Page Goto
- Virtual memory manager
- 2,4, or 8 colour windows and colour printing
- Long path name support
- Low, medium & high resolution IFF support
- Support for interlaced windows

and it's
FAST

What they had wrong was that it does have a Collins English dictionary. More importantly, the price is no longer £79.95

£39.95

"..incredible value..."

Scribble Cover disk offer!!

Buy the OFFICIAL Manual and the ENGLISH Dictionary disk for your Scribble cover disk

£9.95 inc VAT

Simply fill in the coupon opposite and send it along with your cheque or ACCESS/VISA details and add £1-50 for post & packaging to:

Name _____

Address _____

Please send me:

Scribble Manual & Dictionary disk ...

Excellence V 3.0.....

PRICE/PERFORMANCE BREAKTHROUGH!

PAGESETTER³

ONLY **£49⁹⁹**

**DESKTOP PUBLISHING, WORD PROCESSING, & PAINT SOFTWARE
INTEGRATED INTO ONE EASY-TO-USE PUBLISHING PACKAGE!**

Includes Everything You Need To Start Publishing Your Own Newsletters, Flyers, Resumes, Invitations and More!

Great Easy-To-Use Desktop Publishing Software



- Place text and graphics anywhere on the page for design freedom!
- Automatic text run-around graphics for a professional look!
- Great on-screen colour! Up to 256 colors with any Amiga with the AGA chip set (like A4000)!
- Supports AGFA Compugraphic and PostScript Type 1 fonts for Jaggie-free fonts on any printer!

- Variety of type styles including bold, italic, underline, outline, shadow, and pattern fills!
- Sharp output to the highest possible resolution of Preferences and PostScript printers, including colour!
- Hot-links to word processor and paint program for fast text and graphics changes with no hassle!

Word Processor

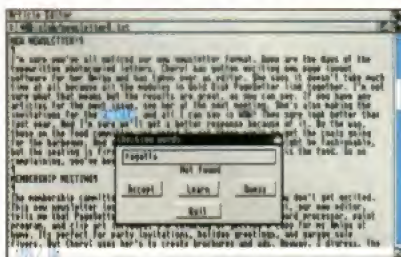

Hot-linked!

- Import IFF and Professional Draw graphics then crop and size!
- Free clip art included! Over 120 pieces of full colour, high resolution structured clip art to add instant zip to your documents!
- Built-in structured drawing tools for lines, rectangles, ellipses & polygons!
- Layout rulers, margin/column indicators, and grids with snap-to for precision alignment and layout!
- 5 levels of magnification!
- Page sizes up to 17" x 17"!
- Runs on all Amigas with 1MB RAM and 2 Drives!

Hot-linked!

Paint Program



- A mouse click brings your graphic here for super fast editing and changes!
- Full paint program lets you create or edit graphics quickly and easily!
- Powerful paint tools!

GOLD DISK PAGESETTER³ SMASHES ALL PRICE BARRIERS!

Now everyone can create their own newsletters, flyers, resumes, invitations and more, because only £49⁹⁹ puts a complete publishing system on your Amiga! You get great DTP, Word Processing, and Paint Software that's hot-linked together for maximum creativity and ease-of-use.

**Get started today, it couldn't be easier or more affordable!
Call 081 309 1111, or see your dealer right away.**

And if you already own PageSetter, for a limited time you can upgrade your current version to PageSetter³ for only £25⁰⁰, call 081 309 1111 now!

SILICA SYSTEMS

081 309 1111

HOTLINE

GOLD DISK
P.O. Box 789 Streetsville
Mississauga, Ontario L5M 2C2 Canada

*Plus VAT. Gold Disk, Gold Disk PageSetter, and Professional Draw are trademarks of Gold Disk Inc. All other products mentioned are trademarks of their respective owners. Dealers, please call SDI now to place your orders: 081 300 5440.

HOW TO CONTACT AMIGA FORMAT

You can be certain of getting your enquiry to the magazine dealt with, but only if you make sure you're addressing your letter to the right person or place.

- We can never give personal replies by mail, so don't send us a stamped-addressed envelope.
- We can under no circumstances give personal replies by fax, so please don't ask us to.
- We are available for enquiries by telephone every Tuesday between 11am and 7pm, and we'll be happy to talk to you then.
- Our advertising department can help with problems concerning companies who advertise in the magazine if you phone during normal office hours.
- Our subscriptions service and the **Amiga Format** Mail Order department are not in the same building. They can be contacted on 0458 74011.

WORKBENCH

If you have any problems with the technical side of your Amiga, with hardware or with serious software, Pat McDonald will try to answer you in the mag. Or, if you have any advice for others or any handy tips to share, send it in and you could win a prize. WORKBENCH, **AMIGA FORMAT**, 30 MONMOUTH STREET, BATH BA1 2BW.

GAMEBUSTERS

If you've just found the cheat mode, mapped out the levels or found all the passwords for the latest game, send the info to Nutts and you could win a prize. Or, if you're stuck, ask Helping Hand for advice – or solve someone else's problem and win a prize! NUTTS, GAMEBUSTERS **AMIGA FORMAT**, 30 MONMOUTH STREET, BATH BA1 2BW.

LETTERS

The letters pages are there for you to air your views and share your opinions: please remember not to ask questions that should be in Workbench! Damien is looking for thought-provoking or entertaining letters, the shorter the better. Prizes given for the best two. LETTERS TO THE EDITOR, **AMIGA FORMAT**, 30 MONMOUTH STREET, BATH BA1 2BW.

COMPETITIONS

To enter a competition, write the answers and your name, address and phone number on the back of a postcard or a stuck-down envelope and send it in. You can enter as many times as you wish, but all entries must be posted separately: don't put several entries in one envelope together, or include entries with letters to any other part of the mag. COMPETITION, **AMIGA FORMAT**, 29 MONMOUTH STREET, BATH BA1 2DL.

SPECIAL OFFERS

If you've ordered something from the **Amiga Format** Mail Order section and you've got a problem, please remember that we on the magazine don't deal with it at all. Write to Mail Order at our Somerton address or telephone 0458 74011. **AMIGA FORMAT** MAIL ORDER, THE OLD BARN, SOMERTON, SOMERSET TA11 7PY.

SUBSCRIPTIONS

Similarly, if you move house and want to make sure your copy of the magazine catches up with you, then send the new address to: **AMIGA FORMAT** SUBSCRIPTIONS, THE OLD BARN, SOMERTON, SOMERSET TA11 7PY.

FAULTY COVERDISKS

The disks are duplicated and stuck on the magazine by a firm we employ for that specific purpose. If you have a faulty disk, send it to them enclosing an SAE. We don't keep stocks of disks, so we can't help. DISCOPY LABS, UNITS 2&3, OMEGA TECHNOLOGY CENTRE, DRAYTON FIELDS, NORTHANTS, NN11 4SA.



Letters

Welcome, one and all, to the first Letters page of 1993. As ever, this will remain the premier Amiga forum in this fresh, new year – which basically means it's the place where all things Amiga are discussed not by those boring old writers, who get their say in the rest of the magazine, but by you – the readers. Why not have your say next time around? The address to write to is Letters, **Amiga Format**, 30 Monmouth Street, Bath BA1 2BW.

A1200 THUMBS UP



Can I, through your pages, congratulate Commodore on finally releasing a worthy upgrade to the A500, namely the A1200. 32-bit processor '020 2Mb machine for under £400 is one hell of a bargain.

I'm predominantly a gamer, although I do use my Amiga for music (*OctaMED Pro*, if you're interested) and maybe this will mean arcade-speed games with arcade-sized sprites. *Speedball* on this beast doesn't bear thinking about!

However, what do I do with the Kickstart 1.3 software I have? You said that the new chips can be set up (via the boot screen) to emulate the older chips, but how much of my older software will be worthless?

I'd love to own one of these machines, but are any third parties going to develop Kickstart ROM sharers? I doubt it, because surely it would mean incompatibility with the processor and its speed, or will this not affect it?

Also, for an extra £100 surely Commodore could have included an upgraded sound chip? After all, even sub-£500 the A1200 would still have been a bargain. Maybe then the music industry, as well as software houses, would take the machine seriously.

NR McIntosh, Warley

PS Why not offer readers a free subscription to your mag for a decent thought-provoking letter? Beats a T-shirt any day!

Taking your last point first, the reason we don't offer a subscription as a prize is because a prize letter winner might be a subscriber. Having said that, I like the idea. You're the first to win a free subscription and a smart AF pin badge for a letter prize.

Please indicate on your letters from now on whether you'd prefer a subscription and a pin badge or a binder and a T-shirt if you are lucky enough to win a prize – and we've got some new 1993 T-shirts under preparation now.

You're quite right that the A1200 is an extraordinary machine, but the £399 price is important. Commodore made the point at its launch that they could have included the high-density disk drive (stores twice as much data on a floppy) or a DSP (Digital Signal Processor) chip for improved sound, but bearing the price limit in mind the software houses voted for the 2Mb of chip memory.

A Kickstart ROM sharer would not conflict with the processor and could, indeed, make the A1200 even more compatible. As for how much of your software will run on the A1200, well, it's anyone's guess. We reckon the hit rate is pretty good and is certainly worth the risk of buying an A1200.

A1200 THUMBS DOWN?

Could you tell me what will happen to the A600? And if it does get scrapped, is there going to be a part-exchange for the A1200?

In November, I bought an A600 thinking it was

Continued overleaf

Vision On

Got a picture you're proud of? Send it in, see it in print and win an **Amiga Format** binder! Since Letters is where you get to contribute your words, we thought it would be the perfect place to see your pics on display too. However your image was created, whether you've sketched it in *DPaint* or generated it with a ray-tracing package, we'd like to see it. Only the best will make it into these hallowed pages. Send your entries on disk in IFF format to The Gallery, Letters, **Amiga Format**, 30 Monmouth Street, Bath BA1 2BW.



ED-209 By Nils Erichsen of Skien in Norway.



going to be the best of the Amigas for the price. Then clever old Commodore brought out the A1200 and I thought this was going to compete with the PCs, then I read the review in your magazine and saw the price was only £399.

You might be thinking, well, he's got a perfectly good computer. But if I had known that the A1200 would be only £100 more than my first choice would be the A1200.

Colin Todd, Newark

Fair point. The A1200 is a wonderful machine and the great thing about it is precisely that everybody wants one - it's recreated the buzz of the A500 six years ago in that respect, and at the same price of £399.

That having been said, the A600 isn't dead - never mind the A500 and A500 Plus. We'll still be getting as much in the way of great games (and also serious software) as we have ever had.

And in some ways, there's an even bigger shake-up on the way. When CD arrives in style, an awful lot of us will be looking on in envy and discovering that it will cost quite a bit to upgrade.

You pays your money and you takes your choice. Right now, I'd choose an A1200, but you can't regret owning any kind of Amiga.

CDTV FAN

At this moment in time, I've had my CDTV for five days. I thought I'd died and gone to heaven! Fantastic.

On the first day I rushed in to my electrical retailer and bought Domark's Trivial Pursuit. OK, I know it was £50 - but surely worth it. I've been playing it for almost five days and nights non-stop - well, minus sleeping, going to work and eating and... well, you know.

May I just ask, can we have more space in your mag? If anybody has been wondering whether or not to buy a CDTV, then please take the opportunity now. You will not regret it!

Colin McAllister, Nelson

No, you can't have more space. As it is, we review every CDTV title that comes out and also every piece of hardware for it (one so far, the internal hard drive from Calculus, with more to come in the form of an external hard drive next month).

I've been accused recently of having a Swiss bank account in which to stash the backhanders Commodore dish out in return for our continued support for the CD concept. Wouldn't it be nice!

But anyway, I'd just like to make the position clear. I really wouldn't advise anyone to get a CDTV at the moment. It needs Workbench 2 and more RAM before it's a viable concept, and a new version with the AA chip set in would help immensely.

What I am in favour of (and, by policy, the

magazine is too) is the idea of CD as a storage medium for entertainment software. It will happen, and if you're against it, you're like Canute trying to hold back the tide.

COMMENT

Congratulations on the article 'The Year Ahead' in the latest issue. I read it with great interest.

A plea from me! As you know, I am responsible for fostering CD development in Europe with the development community. Many owners of CDTV are using their systems as Amiga computers and it would be of great help if you could declare on your Coverdisks whether or not they work on a CDTV, or on the A500 Plus with the A570 drive.

The reason is twofold. Firstly to give comfort to CDTV owners. Secondly to encourage the development community to write system-legal software, allowing for the presence of CDFS. In this way we can 'future-proof' software, and encourage developers to prepare for CD versions.

**Jim Mackonochie,
General Manager,
CDTV Development,
Europe**

As a matter of policy we like to ensure that all software on the Coverdisks is compatible with all versions of the Amiga, and in this respect we treat the CDTV as just another kind of Amiga. We wouldn't single it out for labelling any more than any other machine.

System-legal programming is a bit of a can of worms. Many developers we have spoken to are keen on the idea of making all their software hard-drive installable, which goes hand in hand with system legal. However, many also feel they can only achieve the best quality by ditching the system.

I think the best solution is to emphasise the role of CD as a solution in its own right. After all, hard drives will hardly be necessary for playing games when a CD drive is the commonplace standard. We are committed to CD and are looking to further its cause with developers all over the world. This was part of the reasoning behind that article - to see how aware the Amiga community is of the direction in which the wind is blowing...

1200 TESTED

We were surprised to see that despite the promises of the specification our new A1200 did not seem to be that much faster than the old one. We decided to do some speed tests and I thought you may be interested to see the results.

Many speed tests seem to quote "24 hours ray-tracing time reduced to..." which seemed a bit far away from the average user to us, so we stuck to simple day-to-day operations.

Our two test machines were an A500 Plus which was fitted with 2Mb and a second disk drive, and an A1200 with 2Mb of RAM and two extra floppies. Here's the results, with the 1200's figure first and the Plus' figures in brackets...

Test one: loading *Pagesetter 2* and then loading a two-page document. Loading took 80 (68) seconds and then the project loading took 40 (53) seconds.

Test two: using *DevPac 2* to assemble a 4486-line program. *DevPac* took 47 (40) seconds to boot up, with the assembly taking 25 (38) seconds.

Test three: laying down a perspective brush while using *Deluxe Paint III*. With no anti-aliasing this took 2 (2) seconds and with high anti-aliasing it was 41 (79) seconds.

Test four: a search/replace test in a document with 892 occurrences of a word, using the *Wordworth 2* demo from your Coverdisk. This took an astonishing 640 (880) seconds.

Some of the loading times are slower for the A1200; this is because of the longer reset time which we felt it was valid to include because you have to sit through it.

Taking the averages of these results you find that the A1200 offers a speed increase of 1.4 times over the A500 Plus. A machine code memory cycle test shows the A1200 to be four to five times faster, so the question arises as to where has the extra speed gone?

**Michael Hughes and David Butler,
Brunel University**

It's a very important point. Just because the A1200 is clocked faster doesn't mean it actually will make everything faster.

As you've discovered, the 'pure' speed increase is indeed four to five times. This will only apply in practice to certain kinds of programs, however, and 3D stuff in particular.

Loading from disk will be no quicker, because it's the speed of the disk drive, not the processor, that matters there. One other factor is that your Plus with 2Mb includes 1Mb of fast RAM, which as the name suggests is more rapidly accessed for certain jobs.

But remember, all potential 1200 buyers: just because it's nominally faster doesn't mean it is in every situation.

PIRACY 1

Why does everybody think that if pirated games stopped circulating, that prices would subsequently drop? They wouldn't!

Why were audio CDs so expensive in the first place? Because nobody had the CD players so nobody was buying CDs. Nowadays, LPs are virtually extinct and yet CD prices are still around £14! But why, since CDs represent an enormous proportion of sales, don't

Continued overleaf

AMIGA FORMAT

204

FEBRUARY 1993



Hi-Dive by Mark Lockett from Manchester.



Joe Camel by Ray Catalan of Ruislip.



Liberator by A. Berwick of Liss in Hampshire.

DISSENT AND SENSIBILITY

The Amiga 500 stood still between 1985 and 1991 while the PC has gone from strength to strength and now encroaches on territory once occupied solely by the Amiga.

In the same way Commodore messed around with unsuccessful variants on the C64, I consider the same thing to have happened with the A500 Plus and the A600. Now with the release of the A1200 they have done it again – or rather half-done it!

The two biggest and most unforgivable omissions are a high-density floppy drive and enhanced sound. This is what I wanted from an upgrade to the Amiga A500: VGA-comparable graphics; 256 colours on-screen; hardwired line drawing; MIDI port; high-density floppy; 68030 or 68020; four extended joystick ports (Nintendo type); eight-channel, 16-bit stereo sound or DSP; SCSI interface.

Only three of these have been included, which is just not good enough. I don't think that these are unreasonable considering the basic Amiga architecture is now eight years old. If an upgraded Amiga with just two or three of these had been released every couple of years, at the same rate PCs have increased in power, we might have had all of these additions in a bog-standard home Amiga.

Instead we have the latest cock-up from Commodore – the A1200. Granted it's a leap forward, but again it is half-done. I think they should release another computer, call it the A1800 or A2400 and incorporate all – ALL! – of the above upgrades. I would pay an extra £100 for them.

Lastly I would like to say something on the subject of CD. I've read the answers to the five questions you put to various developers, but nobody mentioned anything about Sony's new mini-disk format. Wouldn't that be an answer? The actual mini-disk is slightly smaller in size than a standard 3.5-inch floppy but can store the same amount of music as a normal CD with just a claimed very slight loss in quality and

thus the same amount of data (640Mb). An important factor, though, is that the mini-disk, as well as producing read-only disks like CDs, can also be used for re-recordable ones just like a normal floppy. Maybe you should investigate the potential for its use as an alternative to the standard floppy.

It seems to me like the perfect solution, until cheap, high-capacity PCMCIA cards are available: I've been told that a gigabyte card with the speed of static RAM has been developed.

Amer Butt, Manchester

To be fair to Commodore, I think they made it quite clear that certain of the items on your list were seriously considered for inclusion in the A1200 – in particular, the DSP chip for improved sound and the high-density floppy were on the drawing board but 2Mb of chip RAM as standard was preferred. The reason they had to compromise was to keep the cost down to £399 – after all, this stuff all costs money.

A high-density floppy should be available as an add-on but makes little sense as part of a standard set-up when the Amiga is moving towards CD. Improved sound is not a pressing priority when extra chip memory allows you to have vastly improved samples.

I firmly believe IDE is better than SCSI for the smaller home machines in the Amiga range because it makes for cheap, portable internal hard drives. MIDI is really a bit unnecessary – I don't think it sells computers – and the four joysticks is one of those rather off-the-wall ideas. Which leaves what? Hard-wired line-drawing, for 3D work. Trouble with that is it could mean changing the Amiga architecture, and with a faster processor to throw speed at the problem, it really becomes less of a necessity.

As for mini-disk, it uses data compression to achieve near-CD quality so the data capacity is actually a lot less. On top of that, the last thing the software industry wants right now is a piratable read-write medium.

Next month Issue 44 March 1993

Hard Driving

Hard drives. Wonderful things, everyone should have one, but not everybody does. We show you what you get for your money, and tell you how to get more for less. We give step-by-step instructions to guide you through the mine field of fitting an internal hard drive in your A600/1200. And a full buyer's guide will reveal which drive is the best quality and which is the best value, no matter which model of Amiga you have.

The Amiga Format Instant Software Library



A quick glance at the Amiga Format software shelf reveals a fascinating array of boxes, but do any of them hold product good enough to make the Amiga Format Instant Software Library? Find out next month.

The Amiga is a powerful computer, but without an adequate collection of software, you could be missing out. Next issue we're going to take a look at every area of home computer usage, from games to 24-bit ray tracing and everything in-between. In each area we'll be making buying recommendations in three price ranges, from the next to nothing right up to the ultra high end (and ultra high priced). A quick browse of our Instant Software Library will enable you to build up a system that will do what you want at a price you can afford. An in-depth read of our indispensable guide will show you just what can be achieved with an Amiga, some imagination and the right software.

Waiting for you at your local shop
from **February 11!**



Winged Serpent from Mr J Lock of Tetbury.





they get any cheaper? Because the manufacturers are making millions and don't fancy making less!

Why on Earth should Amiga games get cheaper? So the software houses make less money? Don't be so naive out there!

Piracy is making more money than it's making losses. Let me explain this to you. Without piracy, I would never even have dreamt of getting an Amiga. I knew someone who got regular loads of games, about 20 a week, all free except for having to buy blanks.

So I reckon that software companies haven't lost a single penny because of me. On the contrary, lots and lots of people have made money because of me having pirate games, and so having bought an A500, 1084 monitor and lots of other hardware and extras.

Paperback Writer of Paris/London

Your last argument is typical selfish tosh and I disregard it utterly. What it completely ignores is the fact that you've got plenty of money to spend on your hobby, but you are not willing to give any of it to the people who spend their lives working to create the games you play.

I'm not talking about the software publishers; I'm talking about the programmers. Many of the most talented have already left the industry because it's simply not worth their while. They can make more money being accountants. You are ripping them off personally, just as badly as if you broke into their houses and nicked all their kit. Since you get hours of fun out of their games, I reckon that's appalling.

Your point about CDs, however, is an interesting one. It's pretty obvious that the music companies ripped us all off on that one, using it as an excuse to cynically manipulate the cost of recorded music; and they'll do it again with DCC or mini-disc if we give them the chance.

The difference with CD storage for games is that the software publishers are committed now, before it really takes off, to ensuring that it works at a reduced price. So they won't be sitting there thinking "Hmm, these £45 prices are a bit profitable, aren't they? Let's not drop the price just yet," and not ever doing it. They'll be committed to it from Day One.

THREE EQUALS FIVE

According to my bookshelves, Douglas Adams wrote four books on the subject of Arthur Dent's galactic misadventures and... err... four books do not exactly constitute a trilogy, right? Yet that's exactly what Andy Nuttall quite wrongfully claims in his Infocom review in Issue 40.

See, a trilogy is more like a collection of three related works (Greek 'tri' means 'three', 'logos' means 'word'). Mr Adams' Hitchhiker saga would really be more of a quadrology.

Lasse Nielsen, Brabrand, Denmark

A fair point, but though your use of the English language is most erudite, you're a bit behind the times. Douglas Adams has just released the fifth book in 'the fifth in the increasingly inaptly named Hitchhikers Guide trilogy'. So you see, it's all a bit of a joke, really.

PIRACY 2

I am what you would call a pirate - I have loads of copied games. It occurred to me that if FAST are so hell-bent on catching these people who hack or crack original copies of games, then why don't they read the intros to the cracked games, because they give BBS numbers and PO Box numbers.

Surely between FAST, British Telecom and the Post Office these people can be traced? Granted, some of them live abroad, but other countries must have an equivalent of FAST.

A Nony Mouse, Anywhere

A very fair point, and one I feel is worth hearing in mind for all concerned.

CHEAP DRIVES

I am an amateur radio ham (call F6AFC) and I use my Amiga to send colour pictures all over the world in SSTV mode (Slow Scan Television). I've used the CrossDOS Coverdisk program to import some picture files from PC disks. It's working all right, but can you tell me what software (preferably PD) I could use to convert .SS, .SS1 and .PIC files to .JFF files to use with Spectracolor Jr?

What do you think of Project Bynery's project to use PC controllers and hard disks to build a hard disk that can interface with the Amiga 500? Do you have any information about that subject?

Jean-Pierre Blanchard, Valentigney, France

I've never heard of the formats you mention - if there's anyone out there who knows of a program that does the job, please get in touch.

Meanwhile, we haven't come across the Project Bynery device that you mention, but we did have a really rather interesting story from a reader on the telephone the other day. Apparently, Cumana do an interface that fits inside an A500 trapdoor that allows you to use an old-fashioned PC hard drive of the ST-506 type. The advantage of these is that they are cheap. Our reader had fitted himself out with an 80Mb drive in his A500 for only £70 - a real bargain.

STRANGE...

I use an Amiga 1500 Plus, Workbench 2.04, a GVP Series II hard drive controller and a 52 Mb Quantum drive. All four Workbench disks came with my machine, but my query concerns the Install disk, which for some reason I decided to have a play with.

In the Prefs drawer of this disk there is a Locale icon. Isn't this a Workbench 3 tool? If so, what's it doing on the Workbench 2.04 Install disk? There is no program there, just the icon. I'd just like to know what use it is.

Secondly, can you give me a date as to when the Workbench 3 upgrade kit will be released? Have you got any idea of the price?

MG Westwood, Wolverhampton

It surprises us that there's a Locale icon on your ver-

sion of Workbench, although perhaps it's been there all along and it's just that no-one noticed. The idea of Locale is that it's a function that programmers can use when they want to write software that will be used in different countries and different languages.

By setting his or her Locale, the user then automatically chooses that programs will boot up by using the appropriate language. Programs that take advantage of it will check to see the Locale and boot up appropriately.

As for an upgrade to Workbench 3 - Commodore have made absolutely no announcement of whether they will issue an upgrade, never mind when. The problem, of course, is that the real key to Workbench 3 is its support for the features of the AA chip set, which you can't fit in a lesser Amiga because it needs full 32-bit.

There is a rumour that Commodore will release a version of Workbench 3 for the A500, A600 and so on under the name Workbench 2.1, but again we have no official confirmation of this from Commodore.

TOP OF THE CLASS

I am 12 years old and have owned an Amiga 500 Plus for about a year. In my school we are still using BBC micros for computer studies. I'm not writing to put the BBC down, but I only know of three people in my year who own one. In my class alone, out of 29 pupils 14 have an Amiga of some kind.

I think there should be an Amiga in every school. For a start the Amiga has far superior graphics and sound capabilities; just look at *Deluxe Paint* and *OctaMED*, to name but two. I and many people have asked teachers about getting an Amiga for the school, which they respond to by saying that they are going to get some new computers, namely Acorns and PCs.

The reason they give is that the PC is easier to use and all the Amiga really is is a glorified games machine. This attitude towards this amazing machine is very sad. Join the crusade to get Amigas into school.

Daniel Thomas Gibbins, Swansea

Sadly, the fact of the matter is that you people - the pupils - know an awful lot more about computers than your teachers do. Worse still, most of the decisions on which computer to buy are made by the LEA (Local Education Authority) and not by the school, so your teachers actually don't have any choice.

A few enlightened County Councils have realised not only that the Amiga is a superior machine in itself, but also that it is to the advantage of schools to use computers that the pupils are familiar with. If you lived in Somerset you might well be using an Amiga in your art classes, or in Birmingham you might be learning music with one.

Spot the shot 43



Simply identify the game that this small portion of a screenshot is from, write the answer on a postcard with your name and address and send it in to us.

The address is Spot the Shot 43, *Amiga Format*, 30 Monmouth St, Bath BA1 2BW. The first correct entry out of the hat every month will win a fabulous *Amiga Format* T-shirt!



The winner of Spot the Shot 41 is Koubdjanian Sylvian from Lyon in France. There's an *Amiga Format* T-shirt on the way to Koubdjanian, who enters spot the shot every month, and always on nice postcards.



AMIGA PERIPHERALS

QUALITY AMIGA PERIPHERALS WITH A 2 YEAR WARRANTY

Silica Systems are pleased to present the GVP range of peripherals. GVP are the world's largest third party manufacturer of peripherals for the Amiga range and have a reputation for high specification, quality products. The company was founded only four years ago by a man who knows about the Amiga, Commodore's ex-Vice President of Technology. He, along with a team of Amiga experts including other ex-Commodore staff, understand the add-on requirements of Amiga owners better than anyone. Not only do GVP provide peripherals that Amiga owners want, they also offer peace of mind, with a 2 year warranty on the products they manufacture. So, if you are looking for the very best in peripherals for your Amiga computer, look no further than GVP.

FREE BROCHURE
RETURN THE COUPON FOR YOUR COPY

PC EMULATOR

PLUG-IN OPTION FOR HD8+ & A530



- 16MHz 80286 processor
- 287 Maths Co-Processor socket
- 512K of PC RAM plus the use of Amiga RAM
- Supports Hercules, CGA, EGA/VGA (monochrome) and T3100 video modes
- Runs MS-DOS (3.2 and upwards) plus thousands of other PC programs

This powerful 286 emulator module simply plugs into the "mini-slot" of the GVP HD8+ or A530 (without invalidating the warranty). It has full access to the Amiga's resources and allows you to run PC and Amiga programs at the same time, giving you two computers in one.

£149
Ref. EMU1550

GVP's HD8+ hard drive and A530 hard drive with 40MHz accelerator, represent the highest quality Amiga 500 peripherals, at very affordable prices. Each incorporates a fast action hard drive, RAM expansion capability, custom VLSI chip and FaaASTROM SCSI driver, for unbeatable performance.

The HD8+ hard drive offers up to 8Mb of standard internal Fast RAM expansion and the A530 Combo, up to 8Mb of 32-bit wide fast RAM expansion. Both feature a SCSI controller, which supports up to 6 additional devices, and an Autoboot/Game cut-off switch. Both are available in 40, 80, 120 and 213Mb hard drive versions.

In addition, the A530 Combo zooms the Amiga forward with an 030 accelerator, running at a blistering 40MHz. This enables your Amiga 500 to run at an incredible 12.1 MIPS, faster than an Amiga 3000! No other product in the world combines all the features found in the A530 Combo! A plug-in PC emulator option, shown below, is available for the HD8+ and A530 Combo.

	HD8+	A530
HARD DRIVE		
SCSI HARD DRIVE	•••	•••
40, 80, 120 & 213Mb VERSIONS	•••	•••
ULTRA FAST ACCESS	•••	•••
TRANSFER RATE UP TO 2.180MB/sec*	•••	•••
(*THE RATE OF THE 21300 HD)	•••	•••
ACCELERATOR		
40MHz 68030 CPU	•••	•••
OPTIONAL 68082 MATHS CO-PROCESSOR	•••	•••
RUNS AT 12.1 MIPS (FASTER THAN AN A3000!)	•••	•••
HARDWARE SUPPORT TO MAP KICKSTART INTO 32-bit WIDE FAST RAM FOR FASTER OPERATION (LINE CHARGING THE OPERATING SYSTEM)	•••	•••
RAM BOARD		
UP TO 8MB OF 8 OR 9-bit FAST RAM (8 OR 9-bit WIDE SIMMS - 120ns OR QUICKER)	•••	•••
UP TO 8MB OF 32-bit WIDE FAST RAM (32-bit WIDE SIMMS - 60ns)	•••	•••
1Mb POPULATED	•••	•••
OTHER FEATURES		
HDD/ACCELERATOR 'CUT-OFF' SWITCH FOR 100% GAME COMPATIBILITY	•••	•••
SCSI CONTROLLER FOR UP TO 6 ADDITIONAL DEVICES	•••	•••
VLSI CUSTOM CHIP	•••	•••
FAAST ROM SCSI DRIVER	•••	•••
IDENTICAL COLOUR & STYLING TO THE A500	•••	•••
BUILT-IN VENTILATION FAN TO PREVENT THE UNIT FROM OVERHEATING	•••	•••
DEDICATED POWER SUPPLY	•••	•••
'MINI-SLOT' FOR FUTURE EXPANSIONS (E.G. PC EMULATOR)	•••	•••
REMOVABLE MEDIA SUPPORT	•••	•••
DIRECT MEMORY ACCESS (DMA) STYLE FOR ULTIMATE PERFORMANCE	•••	•••
EASY-TO-USE SOFTWARE	•••	•••
2 YEAR WARRANTY	•••	•••



PRESS COMMENT:

'Superb build, excellent aesthetics and blinding speed make this the best A500 hard drive' -
AMIGA SHOPPER (HD8+)

'GVP claims this is the fastest hard drive in the world and none of our tests could prove that wrong - Untouchable. THE choice' -
AMIGA SHOPPER (HD8+)

'Still the best hard drive' - 92% -
AMIGA FORMAT 11.91 (HD8+)

'GVP have done it again' - 94% -
AMIGA FORMAT 9.92 (A530)

'... the build quality is excellent - in terms of performance, their gear is the best - their equipment is worth every penny' -
AMIGA FORMAT 9.92 (A530)

NOW IN STOCK!

40Mb HARD DRIVE ONLY £349

HARD DRIVES & ACCELERATORS

PRICES FROM:

£349

MODEL	40Mb	80Mb	120Mb	213Mb
HARD DRIVE HD8+	£349 <small>Ref. HD8030</small>	£449 <small>Ref. HD8040</small>	£529 <small>Ref. HD8052</small>	£699 <small>Ref. HD8082</small>
A530 COMBO HARD DRIVE & ACCELERATOR	£749 <small>Ref. HD8032</small>	£849 <small>Ref. HD8042</small>	£929 <small>Ref. HD8054</small>	£1099 <small>Ref. HD8084</small>

FOR ALL AMIGAS



SOUND SAMPLER

- 8-bit stereo sampler
- Plugs into parallel port
- MIDI support for song input
- Extensive editing features

For the semi-professional and audio hobbyist a high quality 8-bit stereo sound sampler that connects into the parallel port on any Amiga 500, 600, 1200, 1500, 2000 or 3000 computer. Combined with one of the best, most powerful and easy-to-use sound and music editing programs available. Includes 4-track soundtracker file compatible sequencer.

MUS 2500 **£39.95**



VIDEO GENLOCK

- 2x Composite Video, 1x S-VHS inputs
- RGB Composite video & S-VHS outputs available simultaneously
- Sound mixer, 2 mono inputs and 1 output
- Full software control via control panel, hotkeys and/or ARexx

GVP's G-lock genlock is a true price-performance breakthrough. The G-lock genlock works with all Amiga computers and even supports the new Chroma Key mode of the ECS-A4 chip set. It's the only choice for the mid-range Amiga video enthusiast.

VID 2500 **£349**

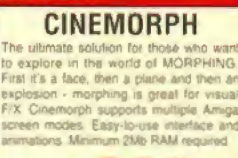

CINEMORPH

The ultimate solution for those who want to explore in the world of MORPHING. First it's a face, then a plane and then an explosion - morphing is great for visual FX. Cinemorph supports multiple Amiga screen modes. Easy-to-use interface and animations. Minimum 2Mb RAM required.

ASC 4422 **£99.95**

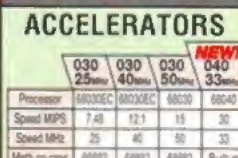

ACCELERATORS

	030 25MHz	030 40MHz	030 50MHz	NEW! 040 33MHz
Processor	68030C	68030C	68030	68040
Speed MIPS	7.48	12.1	15	30
Speed MHz	25	40	50	33
Math co-proc	68082	68082	68082	Built-in
Standard 32-bit RAM	1m	4m	4m	4m
Maximum 32-bit RAM	13m	16m	15m	15m
Extras	SCSI	SCSI	SCSI	SCSI SerPar
Code	UPS 010	UPS 020	UPS 030	UPS 040
PRICE	£499	£799	£1199	£1499

All GVP G-Force accelerators can be turned into a hard card by adding a Mount Kit, GVA 4251, £34.95, making it the ULTIMATE Amiga 1500/2000 peripheral. Any 1" SCSI drive can then be mounted on to the accelerator.



HARD CARDS

- Factory installed Hard Drives
- 0, 40, 80, 120, 213, & 420Mb options
- On-board 8Mb memory sockets
- Add up to 6 SCSI devices

The Impact if HCB hard cards are the equivalent of the HD8+ hard drive, but for the 1500 & 2000. They are some of the fastest hard drives available and incorporate an unpopulated 8Mb RAM expansion.

0Mb Ref. HCB 1000 **£129**
40Mb Ref. HCB 1040 **£329**
80Mb Ref. HCB 1080 **£399**
120Mb Ref. HCB 1120 **£449**
213Mb Ref. HCB 1160 **£699**
420Mb Ref. HCB 1200 **£999**



VIDEO ENHANCER

- 16 million colours @ 768 x 580 PAL Res
- Supports comp video, S-VHS & RGB
- Broadcast quality genlock
- Now with RGB splitter

Impact Vision 24 is the latest 24-bit Professional Video Adapter. It features 16 million colours on screen at once, built-in genlock, flicker free, frame buffer, frame grabber and digital keyer. Supplied with Caligen-IV24 3D modelling and rendering software. Scans V24 video using software. (you Macro Paint 24-bit paint package. A1500/2000 requires additional adapter, GVA 5224, £49.95)

IV-24 - VIU SPLITTER Ref. VIO 1000 **£1499**
IV-24 - VIU TRANSCODER Ref. VIO 1100 **£1899**

ALL PRICES INCLUDE VAT - DELIVERY IS FREE OF CHARGE IN THE UK MAINLAND

SILICA SYSTEMS OFFER YOU

- **FREE OVERNIGHT DELIVERY:** On all hardware orders shipped in the UK mainland.
- **TECHNICAL SUPPORT HELPLINE:** Team of technical experts at your service.
- **PRICE MATCH:** We normally match competitors on a "Same product - Same price" basis.
- **ESTABLISHED 14 YEARS:** Proven track record in professional computer sales.
- **£12 MILLION TURNOVER (with 60 staff):** Solid, reliable and profitable.
- **BUSINESS + EDUCATION + GOVERNMENT:** Volume discounts available 081-308 0888.
- **SHOWROOMS:** Demonstration and training facilities at our London & Sidcup branches.
- **THE FULL STOCK RANGE:** All of your requirements from one supplier.
- **FREE CATALOGUES:** Will be mailed to you with offers + software and peripheral details
- **PAYMENT:** Major credit cards, cash, cheque or monthly terms.

Before you decide when to buy your new Amiga products, we suggest you think very carefully about WHERE you buy them. Consider what it will be like a few months after you have made your purchase, when you may require additional peripherals and software, or help and advice. And, will the company you buy from contact you with details of new products? At Silica Systems, we ensure that you will have nothing to worry about. We have been established for almost 14 years and, with our unrivalled experience and expertise, we can now claim to meet our customers' requirements with an understanding which is second to none. But don't just take our word for it. Complete and return the coupon now for our latest FREE literature and begin to experience the "Silica Systems Service".

MAIL ORDER HOTLINE
081-309 1111

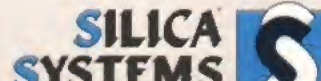

MAIL ORDER: Order Lines Open, Mon-Sat 9.00am-6.00pm No Late Night Opening	1-4 The Mews, Hatherley Rd, Sidcup, Kent, DA14 4DX	Tel: 081-309 1111 Fax No: 081-308 0108
LONDON SHOP: Opening Hours: Mon-Sat 9.30am-6.00pm No Late Night Opening	52 Tottenham Court Road, London, W1P 0BA	Tel: 071-580 4000 Fax No: 071-523 4737
LONDON SHOP: Opening Hours: Mon-Fri 9.30am-7.00pm (Sat 10am-6.30pm) Late Night: Thursday - 8pm	Selfridges (1st Floor), Oxford Street, London, W1A 1AB	Tel: 071-629 1234 Extension: 3914
SIDCUP SHOP: Opening Hours: Mon-Sat 9.00am-6.30pm Late Night: Friday - 7pm	1-4 The Mews, Hatherley Rd, Sidcup, Kent, DA14 4DX	Tel: 081-302 8511 Fax No: 081-309 0017
ESSEX SHOP: Opening Hours: Mon-Fri 9.30am-5.30pm (Sat 9.00am-6.00pm) No Late Night Opening	Keddies (2nd Floor) High Street, Southend-on-Sea, Essex, SS1 1LA	Tel: 0702 462426 Fax No: 0702 460303

To: Silica Systems, AMFOR-0293-68, 1-4 The Mews, Hatherley Rd, Sidcup, Kent, DA14 4DX

PLEASE SEND A BROCHURE ON THE GVP RANGE

Mr/Mrs/Miss/Ms: _____ Initials: _____ Surname: _____

Company Name (if applicable): _____

Address: _____

Postcode: _____

Tel (Home): _____ Tel (Work): _____

Which computer(s), if any, do you own? _____

EMPIRE'S CAMPAIGN COMPETITION

Launching their exciting battle strategy game Campaign on the world, Empire agreed to donate two full eight-video sets of The World at War series and five sets of the Chronicles of World War II magazines as well as 25 copies of the game. Videos, books and a game go to WG Anderson of Glasgow and Philip Baker of Stourport-on-Severn, a set of books and a game to James Mullen of Walton, Adam Bower of Aylsham and MJ Pearson of Halesowen, while the rest are too numerous to mention here!

CALCULUS A570 COMPETITION

AMIGA FORMAT ISSUE 35
Calculus were a bit premature here – it seemed that the A570 was about to go on sale but it turned out that the CD-ROM drive was delayed, hence the lateness of this. Anyway, here are the five lucky winners of an A570: Iain Stewart of Freemantle, Southampton; G Newman of Brimscombe, Stroud; N Grigg of Higham Ferrers, Northants; Peter Boyall of Peterborough; and Mrs M Hodgson of Kings Heath, Birmingham. Well done!

PHILIPS CM8833/II MONITOR COMPETITION AMIGA FORMAT ISSUE 39

Philips started giving away Lotus II with each monitor sold, so to announce the fact they kindly agreed not only to give two monitors away, but also to take someone for a slap-up day out at the British Grand Prix. Fab! The people who will be on the receiving end of the best Amiga games monitor there is are P Hook of Uckfield and Jane Dunn of Liverpool, while the grand prize goes to Steve Taylor of East Dereham.

SSI ROLE-PLAYING GAME COMPETITION AMIGA FORMAT ISSUE 39

US Gold, who distribute SSI's top-notch RPGs in the UK, offered up 10 copies of each of SSI's latest, The Dark Queen of Krynn and Treasures of the Savage Frontier. A brace of adventures is on its way to: Sean Johnson of Grantham; Nick Rogers of Willenhall; Alasdair Thomson of Dundee; Peter Toye of Belgium; Andreas Kersten of Hannover; J Shea of Tottenham; Mark Johnson of Wallasey; Simon Phillips of Liskeard; Simon Brown of York; and Elie Gaby of Streatham.

WILD, WEIRD AND WICKED COMPETITION AMIGA FORMAT ISSUE 40

Commodore kindly donated three of the current A600 game packs for us to give away, complete with Amiga, and they go to the following people: Stuart Crawley of Irvine; Steve Robinson of Dewsbury; and Alan Bradbury of Stockport. Congratulations!

MINDSCAPE'S MIRACLE COMPETITION AMIGA FORMAT ISSUE 41

Four of Mindscape's amazing keyboard-playing tutor systems was a fabulous offer, so how could we refuse their generosity? The fortunate people who will be learning to play in the new year are as follows: Mrs J Curtis of Cardiff; Gary Kilminster of Great Missenden; R Woodrow of Norwich; and Tom Stanbury of Brighton. Applause all round!

Competition craziness

AMIGA FORMAT

It hasn't escaped our attention that we've forgotten to announce the winners of a number of recent – and very exciting – competitions that have been run in this magazine. So as a kind of post-Christmas binge, here's the lucky winners of them all. Is your name here? It may well be – best of luck!

Your guarantee of value

This mag comes from Future Publishing, a company founded just seven years ago but now selling more computer magazines than any other in Britain. We offer:

Better advice. Our titles are packed with tips, suggestions and explanatory features, written by the very best in the business.

Stronger reviews. We have a cast-iron policy of editorial independence and our reviews give clear buying recommendations.

Clearer design. You need solid information fast. So our crayon-wielders highlight key elements by using charts, diagrams, summary boxes, and so on...

Greater relevance. At Future, Editors operate under two golden rules:

- Understand your readers' needs.
- Then satisfy them.

More reader interaction. We draw on readers' contributions, resulting in the liveliest letters pages and the best reader tips. Buying one of our magazines is like joining a nationwide user group.

Better value for money.

More pages, better quality – magazines you can trust.

208

FEBRUARY 1993



Don't miss it
- reserve your copy!

Amiga Format sells out very quickly in many areas of the country – so it's just not worth the gamble that you might miss it. Make sure of your copy by filling in this form and give it to your newsagent. They'll be happy to keep a copy aside for you, or even deliver it direct to your home every month. And remember – if you have problems getting hold of your favourite Amiga magazine, telephone Kate Elston on 0225 442244 and she will be happy to help you.

Please reserve/deliver Amiga Format magazine for me each month, starting with the March Issue, on sale Thursday February 12th.

Name _____

Address _____

Telephone number _____

Note to newsagent: Amiga Format is published by Future Publishing (0225 442244) and is available from your local wholesaler.

Amiga Format Issue 43

EDITORIAL CONTRIBUTORS

Jason Holborn
Scott Johnston
Ed Ricketts
James Leach
Brian Larkman
PhilSouth



Home of Britain's finest magazine.

PROMOTIONS ASSISTANT Tamara Ward

PHOTOGRAPHY Ashton James, Bradford-on-Avon;

COLOUR ORIGINATORS Phoenix Repro
PRINTERS Chase Web, St Ives PLC, Plymouth

NEWS TRADE DISTRIBUTION UK
Future Publishing 0225 442244
NEWS TRADE DISTRIBUTION OVERSEAS:

MMC Ltd 0483 211222

CIRCULATION DIRECTOR Sue Hartley 0225 442244

AMIGA FORMAT

Amiga Power • Amiga Shopper •
ST Format • Sega Power • Mega
Super Play • Total • Future Music
Amstrad Action • Your Sinclair
Commodore Format • PC Answers
PC Plus • PC Format • PCW Plus
Cycling Plus • Mountain Biking U.K.
Needlecraft • Classic CD
Crosstitch • Photo Plus

ADVERTISERS INDEX

16 Bit Centre	184	0423 526322
17 Bit Software	164	0924 466982
1st Computer Centre	30-31	0532 319 444
316 Supplies	22	0446 421316
ACS	74	091 4554300
Ad Energy	66	
Agamic	74	081 342 7662
Amiga Power	62-63	
Amiga Shopper	182-183	
Analogic	51	081 541 4671
Anglia PD	172	0394 2833494
Ashcom	45	0530 411 485
Audition	126-127	0780 55888
Barkman	172	081 546 5941
Battle Axe	166-167	0603 261060
Bell Audio	105	071 221 3132
Brighton Computer Supplies	70-71	0273 506269
Burford	125	0733 391633
Byteware	125	
Cheetah	11, 17	0222 867 777
Computermates	163	0753 631101
Datagem	116	071 608 0624
Dataplex	175	0753 53557
Date!	160-162	0782 744707
Diamond	152-154	0703 232777
Digita	12, 74	0395 270 273
Direct	199	
Direct Computers	179	0630 311 471
Dynamite	194-197	0234 218060
ESP	77	0702 600 557
Eagle Software	107	081 361 2733
Europress	38, 89-91, 132-133	0625 859 444
Evesham	192-193	0386 765500
Firecrest	80	0875 850028
Future Music	126-129	
Future World	141-143	0234 218060
Games Master	94-95	
Gasteiner	75	081 365 1151
Gold Disk	21, 202	
Grapevine	66	0101 914 3572424
HB Marketing	201	0753 686000
Harwoods	96-99, 147	0773 520 252
Hobbyte	138-139	0727 56005
Home Based Business	66	071 701 8490
Indle	51, 158-159	0606 43860
Innovatronics	120	
Intermediates	26-27	0279 600 770
Kingsway	172	0742 750623
Kompat	79	0727 868005
Kosmos	172	0525 873942
Krisalis	105	0709 372 209
LCL	80	0491 579345
Ladbrook	189	0772 203166
MD Office Supplies	131	0689 861400
MJC	200	0462 481166
Matrix Leisure	66	0920 484479
Mega	78	
Merlin	67	0602 44142
Microdeal	112	
New Horizon	198	0989 750260
Novatech	86	0705 664 144
Ocean	86	06 1 832 6633
Omnidale	66	0332 291219
Only The Best	80	0272 401315/6
Owl Associates	209	0543 250377
PC Format	130	

PD Soft	169	0702 566933
PD Warehouse	175	081 290 6140
Phoenix	46-47	0532 311 932
Post Haste	81	0227 764204
Power Computing	60-61, 123, 210, 1BC	0234 843 388
Premier Mail Order	155	0268 271172
Premier Micros	80	0480 300738
RC Simulations	66	0272 550900
RSD	149	0992 584205
Romford Computer Centre	115	0708 735006
Sidmouth Software	175	0395 87073
Silica	85, 87, 101, 145, 207	081 309 1111
Siren Software	41	061 724 7572
Softstore	85, 125	0753 686 000
Software Demons	85	0736 331 039
Software Supreme	50	081 365 034
Spectra Video	55	081 900 0024
Stanhouse Entertainment	106	0244 382 435
Super Play	84	
System Compac	115	
Talking Birds	59	0702 523 607
Thalion	56	010 49 524 124939
Trilogic	92-93	0724 691 115
US Gold	35	021 625 3388
Ubisoft	73	081 343 9055
United PD	170-171	0983 529594
WTS	102-103, 179	0582 491 949
Walkabout Music	105	0726 813 807
We Serve	134	0705 325354
Yew Tree	115	0953 452 803

LOWEST PRICED TOP QUALITY RIBBONS

	1 off	2+	5+		1 off	2+	5+
Amstrad DMP 2000/3000	2.80	2.65	2.45	Star LC10/20 Black	2.29	2.14	1.94
Amstrad DMP 4000	3.66	3.51	3.31	Star LC10/20 Colour	6.00	5.85	5.65
Citizen 120D/LSP10/Swift 24/9	2.85	2.70	2.50	Star LC200 Black	3.00	2.85	2.65
Citizen Swift 24 Colour	12.81	12.66	12.46	Star LC200 Colour	9.78	9.63	9.43
Commodore MPS 1220/1230	4.50	4.35	4.15	Star LC24-10/200 Black	2.86	2.71	2.51
Epson LQ400/500/800/850	3.45	3.30	3.10	Star LC24-10/200 Colour	9.63	9.48	9.28
Epson FX/MX/RX80/FX/LX800	2.90	2.75	2.55				
Epson FX/MX/RX100/FX/MX1000	3.36	3.21	3.01	Canon BJ-10 Inkjet Cartridge	Original 17.54 each		
Epson LX80/86/90	2.12	1.97	1.77	HP Deskjet Cart. (Double Cap)	Original 21.79 each		
NEC Pinwriter P2200	3.03	2.88	2.68	Canon BJ-10 Refill (Twin Pack)	11.00 each		
Panasonic KXP1123/1124/1140	3.46	3.31	3.11	HP Deskjet Refill (Twin Pack)	11.00 each		
Panasonic KXP1080/1180/90/1592	2.89	2.74	2.54				

Ring for ribbons, inkjet cartridges and inkjet refills not listed

Ring us and we will beat all other prices

0543 250377

Ring us or send cheques to:

0543 250377



Owl Associates, Dept 35, Owl House,
5 The Brambles, Lichfield, Staffs WS14 9SE



ALL PRICES INCLUDE VAT & DELIVERY

PREMIUM BULK 3.5" DS/DD DISKS

25	10.99
50	20.50
100	36.99
250	84.99
500	164.99

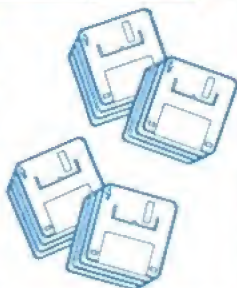

ALL DISKS ARE FULLY GUARANTEED AND ARE COMPLETE WITH LABELS

3.5" SUPERIOR LOCKABLE DISK BOXES

100 Capacity	4.49
120 Capacity	6.49

3.5" PREMIUM DISKS WITH OUR BOXES

100 Cap. box + 50 3.5" DS/DD	24.49
120 Cap. box + 100 3.5" DS/DD	42.99
90 Cap. Bank box + 50 3.5" DS/DD	29.49

3.5" BANK BOX - 90 CAPACITY

A SUPERB PRODUCT WHICH IS BOTH LOCKABLE AND STACKABLE

ONE	9.95
TWO	18.95
THREE	26.95



SNAP COMPUTER SUPPLIES LTD

HOTLINE

0703 457111



RIBBONS - POST FREE

Full Mark Brand	2 off	4 off
	PRICE EACH	
Citizen 120D/124D Swift 24	2.75	2.55
Citizen Swift 24 Colour (Compat)	12.95*	
Panasonic KXP 1080/1123/1124	3.25	3.05
Star LC10/LC20	2.60	2.40
Star LC10-4 Colour	5.90	5.70
Star LC24-10	2.95	2.75
Star LC24-10 Colour (Compat)	9.95*	
Star LC200	3.00	2.80
Star LC200 Colour (Compat)	9.95*	
Star LC24-200	2.95	2.75
Star LC24-200 Colour (Compat)	9.95*	
Ribbon re-ink	12.95	

Minimum order - 2 ribbons, except those marked with an asterisk *

ACCESSORIES - POST FREE

Amiga External Drive	49.99
A500 1/2MB upgrade with clock	23.99
A500 1/2MB upgrade without clock	21.99
Mouse Mat	2.99
Mouse Holder	2.99
Roll 1000 3.5 Disk Labels	8.99
Amiga A500 dust cover	3.50
Phillips monitor cover	3.99
Star LC10, Star LC20 covers	
Star LC24-10, Star LC24-200 covers	3.99

All products are subject to availability - All prices include VAT. Please add £3.50 p+p for disks and boxes. E&OE.



SNAP COMPUTER SUPPLIES LTD Fax: 0703 457222

Unit 16, The Sidings, Hound Rd, Netley Abbey, Southampton SO3 5QA



Award winning innovative products from Power Computing Ltd

A2000 Hard Cards

GVP Series 2 HD

- Up to 8Mb SIMM RAM on-board
- Supports external SCSI devices
- 14MHz SCSI controller

Bare	£129		
40QMB 0MB	£249	80QMB 0MB	£349
40QMB 2MB	£299	80QMB 2MB	£399
40QMB 4MB	£349	80QMB 4MB	£449
40QMB 8MB	£429	80QMB 8MB	£539

Nexus Hard Card



- Up to 8MB RAM on-board

Bare	£129		
40QMB 0MB	£249	80QMB 0MB	£349
40QMB 2MB	£299	80QMB 2MB	£399
40QMB 4MB	£349	80QMB 4MB	£449
40QMB 8MB	£429	80QMB 8MB	£539

Bare SCSI Hard Drive

40 Quantum	£179	80 Quantum	£229
------------------	------	------------------	------

(Suitable for GVP G-Force, GVP HD or Nexus HC)
Other sizes of HD available, please call

RAM Expansion

- Aries A1500 / A2000 RAM

2MB	£129	6MB	£209
4MB	£169	8MB	£249

Macintosh Emulator

"This really is the best emulator we've seen for the Amiga. It behaves just as if you really were using a Mac"

Amiga Format Sept 1992

AMax-II Plus

- Amiga 1500 and above
- Runs Mac software
- Runs System 7
- Full support for all SCSI Mac peripherals and the ability to read Mac disks in your drives
- 68020/68030 compatible
- AppleTalk emulation
- Can use Amiga ECS
- Easy to install

AMax-II Plus£229
(Mac ROM chips required)

24-Bit Colour

OpalVision

- 24-bit graphic card
- 16.8 million colours available
- Operates in all standard Amiga resolutions
- VLSI Microcode graphics co-processor
- Double buffered 24-bit and 15-bit animation is available in all resolutions
- 'Palatte-mapped' design updates screen colours in real-time. Fade pictures in and out and change their palettes
- Equipped with 1.5MB of display RAM
- Auto-config for NTSC or PAL
- Available for all Amigas

Software included

OpalPaint

- 24-bit painting and image processing

OpalPresents

- Presentation program
- Control OpalVision images, Amiga graphics and live video
- Includes fades, effects etc.
- Many more features

King of Karate

- 24-bit computer game
- Exciting karate competition
- Demonstrates OpalVision capabilities

OpalVision£699

More information available
OpalVision roaster chip available soon

Monitors

"For a monitor of this quality, the CM8833 is worth every penny"

Amiga Format Sept 1992

"The 4FG is an absolutely smashing monitor that beats every competitor"

Amiga Format Sept 1992

Philips CM8833 Mk2

- With cable
- Available with Lotus Turbo Challenge 2
- On-site maintenance

CM8833 Mk2£199

NEC Multisync 4FG

- For use with Flicker Fixers
- Very high quality
- Built-in degausser
- 15" Screen

NEC Multisync 4FG£549

Optical Hard Drive



- Manufactured by Power Computing
- 128MB on one optical disk
- Read and write optical disks
- 40ms running speed
- Built-in power supply
- High power cooling fan
- 25-way and 50-way SCSI ports
- Thru'port built-in
- SCSI ID switch
- Compatible with major SCSI controllers

128MB optical drive (Internal)£729

128MB optical drive (External)£999

128MB 3.5" optical disk£39.95 each

SCSI controller card
for A1500 / A2000£129
(Compatible with Amiga, PC, and Mac. A SCSI controller is required on the Amiga and PC)

Floptical Disk Drive

- Stores 20MB on one 3 1/2" disk
 - Cost effective mass storage unit
 - Can be used as a 1.44MB floppy with Amiga DOS and AMAX
 - AMAX compatible with DMI Mac driver
 - Packs an entire back-up onto one floppy
 - Additional disks available
 - Internal version for A1500/2000/3000
 - External version for A500
 - SCSI Interface required
- Internal A2000 kit£289
Internal A3000 kit£289
External A500 kit£389
A1500£599

Accelerator

GVP G-Force

- 68030 accelerator board
 - 68882 Maths co-processor
 - DMA SCSI controller on-board
 - 68000 fall-back mode
 - Only CPU slot is used
 - Internal and external SCSI connector
 - Converts to hard card with Hard Drive mount kit
 - 32-bit RAM as standard
- 25MHz 1MB RAM£529
40MHz 4MB RAM£759
50MHz 4MB RAM£1249
Hard drive mount kit£35

Tel 0234 843388

Printers

All printers include cables and next day delivery

Star Printers

LC200 colour	£199
LC24-200 mono	£239
LC24-200 colour	£289

Citizen Printer

Swift 24e	£279
(includes colour kit and AMI)	

Epson Printers

Laser

EPL-4000	£639
EPL-4300	£799
EPL-8100	£1349

Inkjet

SQ-870	£509
SQ-1170	£629
(132 column printer)	

Dot Matrix

LQ-570	£289
LQ-1070	£449
(132 column printer)	



LQ-100	£209
LX100	£189

Supra Modems

Supra Fax Modem Plus	£129
Supra Fax Modem v32Bis	£275
Supra Modem 2400 (External)	£75
Supra Modem 2400 ZIplus (Internal)	£134
Supra 9600	£210

Miscellaneous

Power Mouse	£15
Optical Mouse	£29.95
Replacement optical mouse mat	£9.95
10 Maxell disks, optical mouse, Zipstick	£45
Maxell multi-colour disks (10)	£9.95
Floppy disks bulk	£POA
Aviator 1 joystick	£35
Intruder 1 joystick	£29.99
Maverick 1 joystick	£15.99
Python 1 joystick	£9.99
Apache 1 joystick	£7.99



The Power Computing colour hand-held scanner for the Amiga is now available. This scanner offers the following features

- 4096 colours
- 50-400 DPI
- 4 Scanning modes
- Text
- Greyscale
- Colour halftone
- Colour

The Amiga interface plugs into an A1500/A2000/A3000/A4000 expansion slot with a separate version which connects to the expansion connector of the A500/A500+. The A500 version has a through-port which is compatible with all Amiga 500 expansion peripherals.

The software supplied with this scanner is the new PowerScan Professional 3, which also supports the greyscale scanner and will be available as an upgrade to existing users of PowerScan for £15.

Colour PowerScan v3.0 features

- Real-time 'True-feel' scan option in colour halftone mode
- Images are stored internally as 12-bit graphics, not HAM. This means that no quality is lost due to the Amiga only being able to display HAM images in 4096 colours

- Images are displayed as HAM pictures
- HAM images may be loaded from disk and edited using PowerScan 3
- Image size that can be handled is limited only by the amount of memory available
- Memory does not have to be chip memory as in many art packages
- Images can be saved in various file formats
- View whole image function
- Scale/rotate/skew image or clipboard by any amount
- Crop image
- Clean up, lighten or darken image
- Variable zoom mode
- Draw freehand, lines, circles, boxes and polygons in various fill patterns, brush sizes, paste modes, or with the clipboard image
- Clipboards may be scanned directly, or any shape can be cut from the main image
- The software is compatible with all Amigas
- Supports Workbench 2 and ECS screen modes

Colour PowerScan now available

New v3.0 Scan software

PowerScan Colour v3.0	£239
PowerScan Greyscale v3.0	£115
PowerScan v3.0 software upgrade	£15

The Amiga can only display 16 greyscales

POWER

Award Winning Manufacturers
Power products come with full technical support

Order Form

Name

Address

Postcode

Tel. No.

Description

Credit Card No.

Expiry Date

Signature

I enclose cheque/PO for £

Tel 0234 843388
Fax 0234 840234

Power Computing Ltd
Unit 8 Railton Road
Woburn Road Ind. Estate
Kempston Bedford
MK42 7PN



Established 1985

Specifications & prices subject to change without notice
All trademarks acknowledged, VAT included

(UK mainland only)
48Hr delivery £2.50 24Hr delivery £4.50
Parcel post delivery £1
(Not for orders over £50)

THE MOST ADVANCED SOFTWARE ENTERTAINMENT EXPERIENCE



SimEarth™

Take charge of an entire planet from its birth until its death - 10 billion years later. Guide life from its inception as single-celled microbes to a civilization that can reach for the stars.

variety of graphs and information windows reveal every detail of your planet.

Create an infinite number of worlds. Take over existing planets, or create new, randomly generated worlds.

Control your planet's Geosphere, Atmosphere, Biosphere and Civilizations.

Place life-forms on the land and in the seas. Put various levels of civilization where you want them. Use special Terraforming Tools to change an inhospitable world into a paradise.

Unleash volcanoes, earthquakes, meteors, tidal waves, and other natural (and unnatural) powers to reshape your planet.

View the entire world as either a flat projection or a spinning globe. Multiple maps track everything from continental drift to biological diversity. Close-up views, for inspecting and modifying planets, display climate, life, and data layers.

- Promote life
- Move mountains
- Create and destroy continents
- Terraform hostile worlds
- Influence evolution
- Cultivate intelligent life-forms
- Create civilized dinosaurs, mollusks, mammals, and more
- Guide your intelligent species through the trials of war, pollution, famine, disease, global warming, and the greenhouse effect.

The Living Planet
 Inspired by James Lovelock's Gaia hypothesis, SimEarth simulates the Earth as a single living organism.

TRADEMARK & COPYRIGHT 1990
 MAXIS and WILL WRIGHT
 ALL RIGHTS RESERVED

CBM AMIGA



OCEAN SOFTWARE LIMITED
 6 CENTRAL STREET
 MANCHESTER M2 5NS
 TEL: 061 832 6633
 FAX: 061 834 0650